

# Double-Scan Mapping Sensors



## BWM Series (EtherCAT) PRODUCT MANUAL

**For your safety, read and follow the considerations written in the instruction manual, other manuals and Autonics website.**

The specifications, dimensions, etc. are subject to change without notice for product improvement. Some models may be discontinued without notice.

### Features

- Stable glass substrate detection with using double scan method (patent)
- Sensing distance: glass G size +30 %
- Customized models available
  - sensing channels (4 to 62 channels), optical axis pitch (25 to 200 mm) (patent)
- Communication output: EtherCAT
- Easy installation with installation instruction mode
- Mutual interference prevention, bent optical axis alarm, 9-stage sensing level setting, emitter error alarm
- Bright status indicators on slave units
- EtherCAT® is registered trademark and patented technology, licensed by Beckhoff Automation GmbH, Germany.

### Safety Considerations

- Observe all 'Safety Considerations' for safe and proper operation to avoid hazards.
- ⚠ symbol indicates caution due to special circumstances in which hazards may occur.

**⚠ Warning** Failure to follow instructions may result in serious injury or death.

**01. Fail-safe device must be installed when using the unit with machinery that may cause serious injury or substantial economic loss. (e.g. nuclear power control, medical equipment, ships, vehicles, railways, aircraft, combustion apparatus, safety equipment, crime/disaster prevention devices, etc.)**

Failure to follow this instruction may result in personal injury, economic loss or fire.

**02. Do not use the unit in the place where flammable/explosive/corrosive gas, high humidity, direct sunlight, radiant heat, vibration, impact, or salinity may be present.**

Failure to follow this instruction may result in explosion or fire.

**03. Do not connect, repair, or inspect the unit while connected to a power source.**

Failure to follow this instruction may result in fire.

**04. Check 'Connections' before wiring.**

Failure to follow this instruction may result in fire.

**05. Do not disassemble or modify the unit.**

Failure to follow this instruction may result in fire.

**06. This product is not safety sensor and does not observe any domestic nor international safety standard.**

Do not use this product with the purpose of injury prevention or life protection, as well as in the place where economic loss maybe present.

**⚠ Caution** Failure to follow instructions may result in injury or product damage.

**01. Use the unit within the rated specifications.**

Failure to follow this instruction may result in fire or product damage.

**02. Use a dry cloth to clean the unit, and do not use water or organic solvent.**

Failure to follow this instruction may result in fire.

**03. Do not use a load over the range of rated relay specification.**

Failure to follow this instruction may result in fire, relay broken, contact melt, insulation failure or contact failure.

### Cautions during Use

- Follow instructions in 'Cautions during Use'. Otherwise, It may cause unexpected accidents.
- 24 VDC $\Rightarrow$  power supply should be insulated and limited voltage/current or Class 2, SELV power supply device.
- Use the product, 1 sec after supplying power. When using separate power supply for the sensor and load, supply power to sensor first.
- When using switching mode power supply to supply the power, ground F.G. terminal and connect a condenser between 0 V and F.G. terminal to remove noise.
- When connecting a DC relay or other inductive load, remove surge by using diodes or varistors.
- Wire as short as possible and keep away from high voltage lines or power lines, to prevent surge and inductive noise.
- This unit may be used in the following environments.
  - Indoors (in the environment condition rated in 'Specifications')
  - Altitude max. 2,000 m
  - Pollution degree 2
  - Installation category II

## Cautions during Installation

- Be sure to install this product by following the usage environment, location, and specified ratings. Consider the listed conditions below.
  - Installation environment and background (reflected light)
  - Sensing distance and sensing target
  - Direction of target's movement
  - Feature data
- When installing multiple sensors closely, it may result in malfunction due to mutual interference. Install it by referring to the interference protection and the installation method in the manual.
- Do not use in places where the light-receiving sensor is exposed to direct sunlight or where the ambient illumination is higher than the specification.
- Do not impact with a hard object or bend the cable excessively. That could decrease the product's water resistance.
- Use this product after the test. Check whether the indicator works appropriately for the positions of the detectable object.

## Ordering Information

This is only for reference, the actual product does not support all combinations. For selecting the specified model, follow the Autonics website.

**BWM** ① - ② ③ ④ - ⑤ ⑥

### ① Optical axis pitch

Number: Optical axis pitch (≥ 25 mm)

### ② Sensing CH

Number: 4 to 62 CH

### ③ Control output

EC: EtherCAT

### ④ Operation mode

L: Light ON  
D: Dark ON

### ⑤ External device connection mode

No-mark: Connector type  
T: Terminal type

### ⑥ CH ordering orientation

No-mark: Forward (bottom = 1 CH)  
R: Backward (top = 1 CH)

## Product Components

- Product × 1
- Instruction manual × 1
- Bracket A × 4
- Bracket B × 4
- Fixing bolt × 8

## Sold Separately

- M17 connector cable: C5D617-□P

## Output Connector

- 4-pin connector: TS04515B0000G (5.08 mm pitch)
- Connector socket specification: Contact the manufacture for the socket and cable.

	Specifications	Manufacture
Connector socket (4-pin)	OQ0455510000G	ANYTEK

## Dimensions

- Unit: mm, For the detailed drawings, follow the Autonics website.
- Length of the product can be different by its ordered specification. Refer to the followings.  
length of the product (L) = 105 + {optical axis pitch (P) × (sensing CH - 1)}  
A: 65 to 85 mm, B: 45 to 65 mm

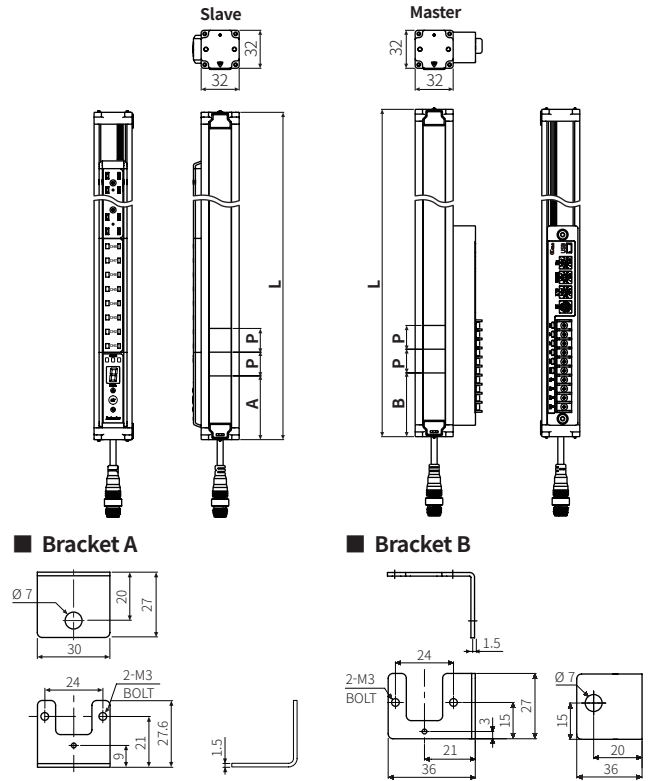

## Connections

### Power and synchronization line terminal

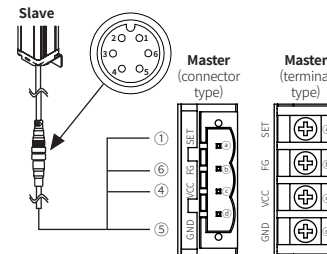

Pin no.			Func.	
	Slave	Master		Cable color
1		Ⓐ	Black	SET
4		Ⓑ	Brown	VCC
5		Ⓒ	Blue	GND
6		Ⓓ	Yellow	F.G.

### Comm. input/output connector

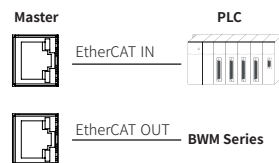

Connector	Pin no.	Func.
Ⓔ	Ⓔ	IN
Ⓕ	Ⓕ	OUT

## Specifications

<b>Model</b>	<b>BWM</b>
<b>Sensing method</b>	Through-beam
<b>Beam pattern</b>	Double scan type
<b>Light source</b>	Infrared LED (850 nm modulated light)
<b>Sensing distance</b>	Glass + 30 %
<b>Sensing target</b>	Transparent or opaque glass plate
<b>CH ordering orientation<sup>01)</sup></b>	Forward (bottom = 1 CH) / Backward (top = 1 CH)
<b>Sensing CH<sup>01)</sup></b>	4 to 62 CH
<b>Optical axis pitch<sup>01)</sup></b>	25 to 200 mm
<b>Response time</b>	≤ 120 ms
<b>Operation mode<sup>01)</sup></b>	Light ON / Dark ON
<b>Function</b>	Installation guide mode, sensing level setting, optical axis misalignment alarm (low light intensity alarm), emitter damage alarm, self-diagnosis
<b>Interference protection</b>	Interference protection by transmission frequency selection
<b>Synchronization type</b>	Timing method by synchronous line
<b>Indicator</b>	Output indicator (red), stability indicator (green), status indicator (green, yellow, red)
<b>Approval</b>	
<b>Weight (packaged)</b>	≈3.42 kg (≈ 5.52 kg) (based on BWM28-50ECD-T)

01) This product is order made.

02) Please refer to the website for KC certification model.

<b>Power supply</b>	24 VDC≐ (ripple P-P: ≤ 10 %)
<b>Current consumption</b>	Master: ≤ 200 mA, slave: ≤ 150 mA
<b>Protection circuit</b>	Reverse power protection circuit, output short overcurrent protection circuit
<b>Insulation resistance</b>	≥ 20 MΩ (500 VDC≐ megger)
<b>Noise immunity</b>	The square wave noise by the noise simulator (voltage: 500 V, period: 10 ms, pulse width: 1 us)
<b>Dielectric strength</b>	Between the charging part and the case : 500 VAC~ 50/60Hz for 1 min
<b>Vibration</b>	1.5 mm double amplitude at frequency of 10 to 55 Hz in each X, Y, Z direction for 2 hours
<b>Shock</b>	210 m/s <sup>2</sup> (≈ 21 G) in each X, Y, Z direction for 3 times
<b>Ambient illumination</b>	Light bulb: 5,000 lx, semiconductor: 5,000 lx
<b>Ambient temperature</b>	15 to 35 °C, storage: 15 to 35 °C (no freezing or condensation)
<b>Ambient humidity</b>	35 to 85 %, storage: 35 to 85 % (no freezing or condensation)
<b>Cable spec.</b>	∅ 5 mm, 6-wire, 250 mm
<b>Connector spec.</b>	M17 plug connector
<b>Output connector spec.</b>	Connector type: 4-pin, 6-pin connector (5.08 mm pitch) / terminal type: 10-pin terminal
<b>Material</b>	Case: AL / ABS, sensing part and Indicator part: PMMA

## Communication Interface

### ■ EtherCAT

<b>Control output</b>	EtherCAT
<b>Comm. protocol</b>	EtherCAT protocol
<b>Association approval</b>	
<b>Physical layer</b>	100BASE-TX (IEEE 802.3u)
<b>Comm. medium</b>	Over CATEGORY 5/E (must be shield cable)
<b>Connection method</b>	Daisy chain
<b>Transmission speed</b>	100 Mbps
<b>Address range</b>	0 to 65535 (16-bit)
<b>Address setting</b>	Software (EtherCAT Master)
<b>Comm. range</b>	Distance between nodes: ≤ 100 m

## EtherCAT I/O DATA Structure

- HIGH: ON, LOW: OFF for bit status.
- Since the above is based on the product of 24 CH, the number of I/O is changeable by product.
- EtherCAT I/O data structure consists of the number of CH+ERROR output BIT+ALARM output BIT.

1st Word	Description	2nd Word	Description
I/O0 [BIT0]	CH1 status	I/O0 [BIT0]	CH17 status
I/O1 [BIT1]	CH2 status	I/O1 [BIT1]	CH18 status
I/O2 [BIT2]	CH3 status	I/O2 [BIT2]	CH19 status
I/O3 [BIT3]	CH4 status	I/O3 [BIT3]	CH20 status
I/O4 [BIT4]	CH5 status	I/O4 [BIT4]	CH21 status
I/O5 [BIT5]	CH6 status	I/O5 [BIT5]	CH22 status
I/O6 [BIT6]	CH7 status	I/O6 [BIT6]	CH23 status
I/O7 [BIT7]	CH8 status	I/O7 [BIT7]	CH24 status
I/O8 [BIT8]	CH9 status	I/O8 [BIT8]	ERROR output BIT
I/O9 [BIT9]	CH10 status	I/O9 [BIT9]	ALARM output BIT
I/O10 [BIT10]	CH11 status		
I/O11 [BIT11]	CH12 status		
I/O12 [BIT12]	CH13 status		
I/O13 [BIT13]	CH14 status		
I/O14 [BIT14]	CH15 status		
I/O15 [BIT15]	CH16 status		

## Unit Descriptions

### ■ Slave

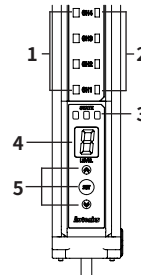

1	Output indicator (red)
2	Stability indicator (green)
3	Status indicator (green, yellow, red)
4	Status display
5	Mode setting key

### ■ Master

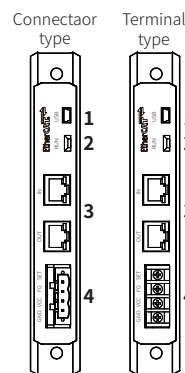

1	USB port: This port is only for firmware upgrade, run mode change, and A/S. Do not use this port for another purpose, or the product can malfunction.
2	Comm. status indicator: It displays the communication status through LED.
3	EtherCAT comm. input/output connector: It is with the communication status indicator which turns on or flashes according to the communication status.
4	Power and synchronous line terminal

## Installation and Adjustment

- If optical axis are not coincident, yellow LED of the status indicator flashes at 0.5 sec interval, and output indicator (red, slave) and stable indicator (green, master) light off. Please readjust the position of Master and Slave and execute teaching again.
- Avoid using the unit in the place where the sensor is exposed directly to the fluorescent light with high speed start or high frequency.

- 01) Mount Master and Slave to face each other.
- 02) Place a glass plate at the guide line and adjust sensor height.
- 03) Touch [SET] key of Slave once without a glass plate and it enters installation guide mode. (shorting SET (gray) and GND (blue) has same function.)
- 04) Adjust Master and Slave up/down/right/left, and check the place where output/stability indicators flash (It displays coincidence of optical axis of all CHs.) and status indicator lights ON. Fix them at this place by tightening screws (tightening torque: 0.39 to 0.49 N m).
- 05) Pressing [SET] key for over 3 sec completes teaching and operates the device in RUN mode.

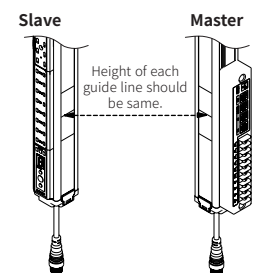

## Mode Switching Method

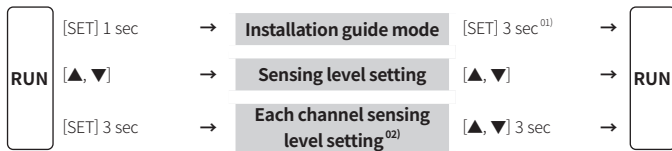

- 01) Entering to the installation guide mode and pressing [SET] key for 3 seconds starts teaching, and the product returns to the run mode after teaching completed.  
 02) When the status display is  $\mathcal{L}$ , select channel to change using [▲, ▼] key and press key. When number of channel is flashing, set sensing level using [▲, ▼] key.

## Operation Timing Chart

### Light ON mode

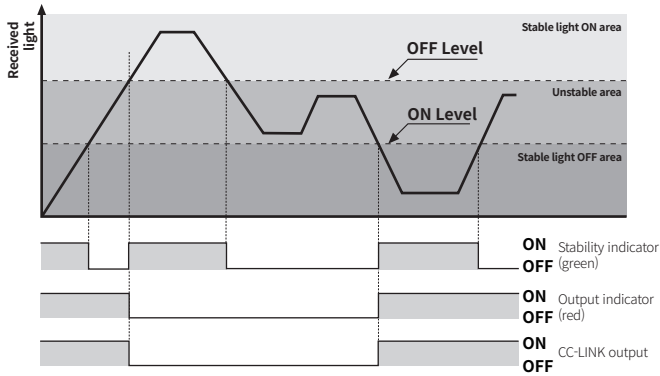

- In Dark ON mode, the waveforms are reversed.

## Operation Indicator

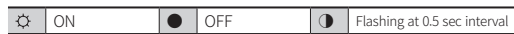

### [Slave] CH indicator

Item	Output (red)	Stability (green)	Item	Output (red)	Stability (green)
Stable light ON	●	☀	Stable light OFF	☀	☀
Unstable light ON	●	●	Unstable light OFF	☀	●
Teaching error	⚡	⚡			

### [Slave] Status indicator

Item	CH indicator <sup>01</sup>	Status display	Operation indicator			EtherCAT output <sup>02</sup>
			Green	Yellow	Red	
Normal operation	-	Sensing level	☀	●	●	-
Teaching error	Flashing (error channel)	-	●	⚡	●	Outputting H at relevant CH, N+1
Malfunction of synchronous line (communication error)	Flashing (all LED)	$\mathcal{L}$ to $\mathcal{G}$ or $\mathcal{L}$	⚡	⚡	⚡	Outputting H at N+1, Outputting H or L at N+2
Emitter damage	Flashing at 0.25 sec interval (LED of the CH)	n	⚡	●	⚡	Outputting H at 1 to N+1
Installation guide mode	Coinciding all CHs optical axis	Flashing (all CHs)	☀	●	●	Outputting H at all CHs
	Optical axis coinciding CH	Flashing (LED of the CH)	●	⚡	●	
	Optical axis not coinciding CH	OFF (LED of the CH)	●	⚡	●	
Teaching	Coinciding all CHs optical axis	ON (all CHs)	☀	●	⚡	
	Optical axis coinciding CH	ON (LED of the CH)	●	⚡	⚡	
	Optical axis not coinciding CH	OFF (LED of the CH)	●	⚡	⚡	
Optical axis misalignment alarm	-	-	⚡	☀	⚡	Outputting H at N+2
Individual optical axis controlling mode	Flashing (relevant CH)	$\mathcal{L}$ to $\mathcal{G}$	●	☀	☀	-

- 01) Except normal operation, stability indicator (green) stands for the master and output indicator (red) stands for the slave.  
 02) N stands for all channel.

### [Master] Communication status indicator

Item	Comm. status indicator (green)	
RUN	Initial status	OFF
	Pre operation status	Flashing at 200 ms interval
	Safe operation status	Repeating 200 ms ON and 1000 ms OFF
	Operation status	ON
L/A IN, L/A OUT	No connection	OFF
	Operation status	Flashing at 50 ms interval
	Disconnection in operation	ON

## Functions

### Installation guide mode

This function displays whether the sensing target is in the stable position of the guide line when installing the product through the output indicator. Entering installation guide mode and pressing [SET] key starts teaching. When teaching, this function detects channels with unstable received light level and adjust received light level of all channels to the same level.

### Sensing level setting

This function sets sensitivity by dividing received light into 9 levels for stable sensing. Use this function when some of the channels shows low sensing level due to the bent glass plate or diffused reflection. Factory default is level 5.

- You can change sensing level of each channel separately in the each channel sensing level setting mode.
- When using the sensing level setting function after setting each channel sensing level using the each channel sensing level setting mode, sensing level settings of each channel are reset.

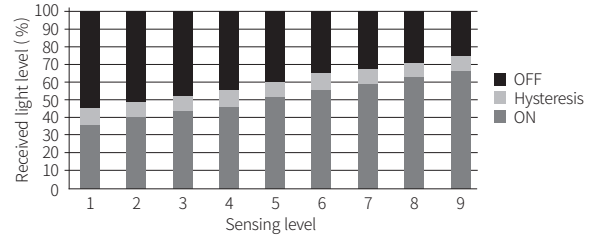

### Mutual interference prevention (transmitted light frequency change)

When you install more than two products, there is a risk of mutual interference. Change the frequency to prevent this interference. Set this function via the setting switches of the emitter / receiver.

Mark	FREQ.	Mark	FREQ.
0	A	3	D
1	B	4~9	Not used
2	C		

### Optical axis misalignment alarm (low light intensity alarm)

Emitted light level can be reduced due to warped product or long-term usage. When nothing is detected during operation, this function checks received light level and outputs alarm at 'OFF level +  $\approx 3\%$ ' of received light level. Emitted light level is returned to the normal level with teaching.

### Emitter damage alarm

Outputs alarm when emitter is damaged due to the long-term usage of emitter elements or strong impact to the product.

### Self-diagnosis

Mapping sensor is able to self-diagnose periodically in normal operation. If error occurs, status indicator displays in which part error occurs.

- Malfunction of synchronous line  
: If there is malfunction of synchronous line, it displays error and outputs signal.

## Troubleshooting

Malfunction	Cause	Troubleshooting
Non-operation	Power supply	Supply the rated power.
	Cable cut, disconnection	Check the wiring.
Non-operation in sometimes	Sensor cover pollution by dirt	Remove dirt by soft brush or cloth and set sensitivity again.
	Connector connection failure	Check the connection area of connector.
Output is ON without a target	Initial sensitivity setting goes wrong	Remove the cause and set sensitivity again.
	There is a strong electric wave or noise generator.	Put away motor, electric generator, or high voltage line.

## Sold Separately: M17 Connector Cable

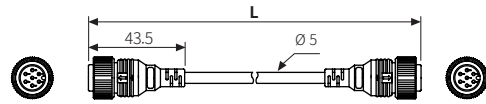

Model	L
C5D617-7P	7 m
C5D617-10P	10 m
C5D617-15P	15 m