

## CLT-80 Transformer

Rev 1.0 (May 27, 2011)

### Set-up and Operation

1. Be sure that the power source for charging this unit is equipped with a circuit breaker.
2. Securely place the power cord into the back of the CLT-80. Flip the switch on the front to turn on the power. The power light should illuminate, indicating unit has power.
3. Attach cord of the electric screwdriver to the transformer. Make sure notch in plug lines up with the notch in the socket. Tighten knurled ground ring.
4. Select HIGH & LOW speed button. Select the appropriate speed for your application.
5. Turn driver on and check for proper rotation. FOR-clockwise, REV-counterclockwise.
6. To apply torque, squeeze the lever (For Push-to-Start models place light downward pressure on the nose of the driver). The driver will automatically stop when the preset torque has been reached.



**Note!** The transformer is designed to operate the HIOS CL-9000 electric screwdriver models.

### Mounting Brackets

The CLT-80 transformer comes with two attachment plates. Please use both plates to secure the transformer for operation.

Be sure the plates are securely attached and then use them to attach the transformer to an appropriate surface in the work area where the transformer will not get in the way of operations.

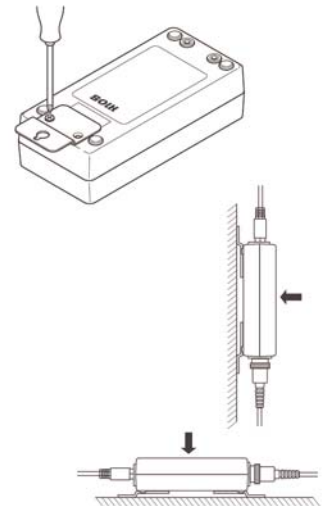
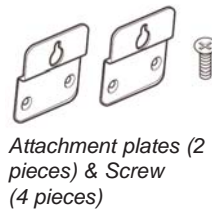

### Storage

1. Store the transformer in a place free from excessive humidity, temperature and dust. Keep it away from metallic objects.
2. Do not place objects on top of the unit.
3. When storing, firmly secure the unit and be sure there is no danger of it slipping or falling.
4. Do not store the unit next to high voltage equipment.
5. Use the fittings provided to secure the transformer to a stable surface.

### Cautionary Notes

1. Connect to a transformer of only the specified voltage.
2. Do not drop the transformer or subject it to violent impact.
3. Do not attempt to use the transformer for any purpose other than that described here.
4. Do not drag the unit by its power cord. Keep the cord away from foreign objects, oil and sharp implements.
5. When disconnecting the power cord, always grasp it by the plug.
6. If the unit overheats, activates a circuit breaker or exhibits other abnormalities, cease operation immediately and send it to Mountz for repair. Do not disassemble or modify the unit.
7. When the unit is not in use, turn the power switch off and disconnect the unit from its power source.

### Specifications:

Output VDC: 20/30V

Input VAC: 100-240V

Fuse: 5A

Size inches (W x D x H): 4 1/2" x 8 1/2" x 2"

Weight: 3.5 lbs.

**Operates with: HIOS CL-9000 models**

**Contact  
Mountz Inc.**  
Phone: 408.292.2214  
Fax: 408.292.2733  
sales@mountztorque.com  
www.mountztorque.com

Looking for fasteners?  
www.mrmetric.com

