



**Torque
Multipliers**

Accessories



RETENTION RING

Used to hold a reaction foot, bar or ring on the Multiplier.
See Page 01.13

Accessories



6 PT. IMPACT SOCKETS

A wide range of durable sockets available.
See Page 01.14

KEY FEATURES

- Accuracy better than $\pm 5\%$.
- Precision tightening and loosening of all heavy duty fastening connections.
- Shuts-off when pre-set torque is achieved. Non-impacting and operates at a smooth, continuous rotation.
- Increases speed and productivity, 5-10 times faster than slow ratcheting hydraulic wrenches. Less expensive than hydraulic wrenches.
- Ergonomically safer than the harmful hammering of impact wrenches. Eliminates frequent and costly repairs of impact wrenches.
- Standard models feature LED Display or "Plus" models feature LC Display.
- Microprocessor controlled. The speed, frequency and torque correspond with built-in controller (no separate box needed).
- Brushless motor design provides low maintenance.
- Over-heat protection.
- Universal AC Input (100-253V / 45-66 Hz).
- The handle can "free float" or locks in set position.

EF & EFW

Electric Torque Multipliers (with built-in controller)

EF Series
In-Line
Mul tiplier



EFW Series
Right Angle
Mul tiplier



PLUS MODELS

Feature LC Display:
Preset torque & rotation angle can be set and displayed as well as adjustable torque direction.



STANDARD MODELS

Feature LED Display:
Preset torque with 19 stages as well as adjustable torque direction.

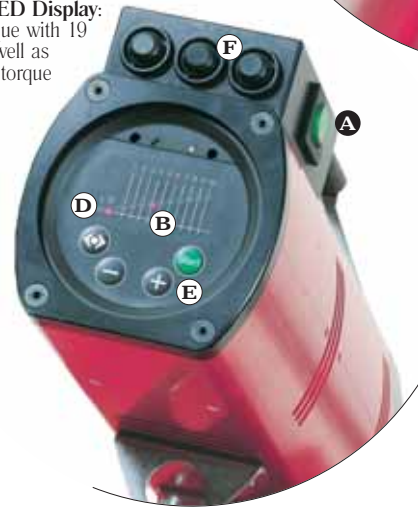

LEGEND

- A** On/Off
- B** Torque Setting
- C** Rotation Angle Setting
- D** Right/Left Indicator
- E** Controls for Settings
- F** Operation Buttons: CW Direction, Start/Stop, and CCW Direction

RENTAL!

Torque Multipliers are part of our Rental Program. Ask a customer service representative about availability.



NOTE!

Remote Control operation available. See Accessories page 01.13

All Weather models available.

EF				EFW				Torque Ranges		Speed RPM
Model	Item #	Model	Item #	Model	Item #	Model	Item #	lbf.ft	N.m	
EF100	210604	EF100Plus	210624	EFW100	210614	EFW100Plus	210634	118 - 796	160 - 1080	33
EF200	210605	EF200Plus	210625	EFW200	210615	EFW200Plus	210635	221 - 1548	300 - 2100	16
EF250	210606	EF250Plus	210626	EFW250	210616	EFW250Plus	210636	320 - 1987	435 - 2695	14
EF300	210607	EF300Plus	210627	EFW300	210617	EFW300Plus	210637	368 - 2286	500 - 3100	12
EF400	210608	EF400Plus	210628	EFW400	210618	EFW400Plus	210638	663 - 3134	900 - 4250	8
EF600	210609	EF600Plus	210629	EFW600	210619	EFW600Plus	210639	811 - 4536	1100 - 6150	7
EF800	210610	EF800Plus	210630	EFW800	210620	EFW800Plus	210640	1327 - 5752	1800 - 7800	4
EF1000	210611	EF1000Plus	210631	EFW1000	210621	EFW1000Plus	210641	1512 - 7228	2050 - 9800	3

DIMENSIONS and WEIGHT						
Model	Square Drive	Spline Dia. mm	D2 mm	Length in.	Length mm	Weight lbs.
EF100	1"	54	85	20.2	515	28.5
EF200	1"	54	85	20.2	515	28.5
EF250	1"	54	85	20.2	515	28.5
EF300	1"	72	98	20.2	515	31
EF400	1 1/2"	72	98	20.6	525	32
EF600	1 1/2"	72	123	21.6	550	42
EF800	1 1/2"	72	148	21.8	555	48.5
EF1000	1 1/2"	91	173	21.8	555	59.5

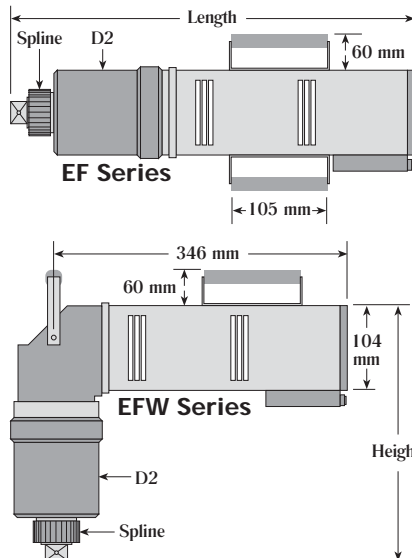

Model	Square Drive	Spline Dia. mm	D2 mm	Height in.	Height mm	Weight lbs.
EFW100	3/4"	54	85	11.2	285	30
EFW200	1"	54	85	11.2	285	30
EFW250	1"	54	85	11.2	285	30
EFW300	1"	72	98	12	305	30
EFW400	1 1/2"	72	98	12.5	320	35
EFW600	1 1/2"	72	123	13.7	350	44
EFW800	1 1/2"	72	148	13.7	350	52.5
EFW1000	1 1/2"	91	173	15	380	64