

HI 720

Conductivity Process Controller with Inductive Probe



TABLE OF CONTENTS

WARRANTY	4
PRELIMINARY EXAMINATION	5
MODEL IDENTIFICATION	5
GENERAL DESCRIPTION & THEORY OF OPERATION	6
SPECIFICATIONS	9
FUNCTIONAL DESCRIPTION	10
INSTALLATION	12
OPERATIONAL GUIDE	14
• SETUP MODE	14
• CALIBRATION MODE	34
• CONTROL MODE	37
• IDLE MODE	43
• LAST CALIBRATION DATA VIEWING MODE	43
• DIAGNOSTIC MODE	44
TEMPERATURE COMPENSATION	46
CONCENTRATION CURVES	48
HOLD MODE	50
IN-LINE CLEANING	52
COMMUNICATION	54
• PC COMMUNICATION	54
• SHORT MESSAGING SERVICE (SMS)	67
• MODEM CONNECTION	71
ERRORS - FAULT CONDITIONS	73
ALARM - ERROR CONFIGURATION	74
SELFTEST PROCEDURES	77
ACCESSORIES	80

Dear Customer,

Thank you for choosing a Hanna Instruments product.

Please read this instruction manual carefully before using the instrument. It will provide you with the necessary information for correct use of the instrument, as well as a precise idea of its versatility.

If you need additional technical information, do not hesitate to e-mail us at tech@hannainst.com or see the back cover for our worldwide contact list.

This instrument is in compliance with the CE directives.

WARRANTY

All Hanna Instruments meters are guaranteed for two years (sensors, electrodes and probes for six months) against defects in workmanship and materials when used for their intended purpose and maintained according to instructions.

This warranty is limited to repair or replacement free of charge. Damage due to accident, misuse, tampering or lack of prescribed maintenance are not covered.

If service is required, contact the dealer from whom you purchased the instrument. If under warranty, report the model number, date of purchase, serial number and the nature of the failure.

If the repair is not covered by the warranty, you will be notified of the charges incurred.

If the instrument is to be returned to Hanna Instruments, first obtain a Returned Goods Authorization number from the Customer Service department and then send it with shipping costs prepaid.

When shipping any instrument, make sure it is properly packaged for complete protection.

PRELIMINARY EXAMINATION

Remove the instrument from the packing material and examine it carefully to make sure that no damage has occurred during shipping. If there is any noticeable damage, notify your Dealer or the nearest Hanna Customer Service Center immediately.

Note Save all packing materials until you are sure that the instrument functions correctly. Any damaged or defective items must be returned in their original packing materials together with the supplied accessories.

MODEL IDENTIFICATION

The models **HI 720 XYZ- α** are conductivity controllers.

The meaning of the last letters is according to the following scheme:

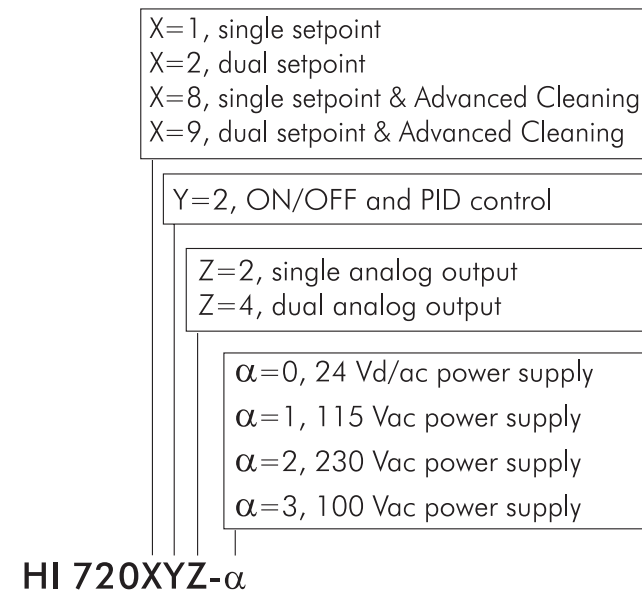

Hanna Instruments reserves the right to modify the design, construction and appearance of its products without advance notice.

GENERAL DESCRIPTION & THEORY OF OPERATION

This instrument allows conductivity measurements without any electrical contact between electrodes and process fluid.

The measurement is based on inductive coupling of two toroidal transformers by the liquid.

The instrument supplies a high frequency, reference voltage to the "Drive Coil", and a strong magnetic field is generated in the toroid.

The liquid passes through the hole in the toroid and can be considered as one-turn secondary winding. The magnetic field induces a voltage in this liquid winding, the current induced in the flow is proportional to this voltage, and the conductance of the liquid one-turn winding is according to the Ohm's law.

The conductance is proportional to the specific conductivity and a constant factor determined by the sensor geometry and installation.

The liquid also passes through the second toroid and therefore the liquid turn can be considered as a primary winding of the second toroidal transformer. The current in the liquid will create a magnetic field in the second toroid, and the induced current can be measured as an output.

The output current of this "Receive Coil" is therefore proportional to the specific conductivity of process liquid.

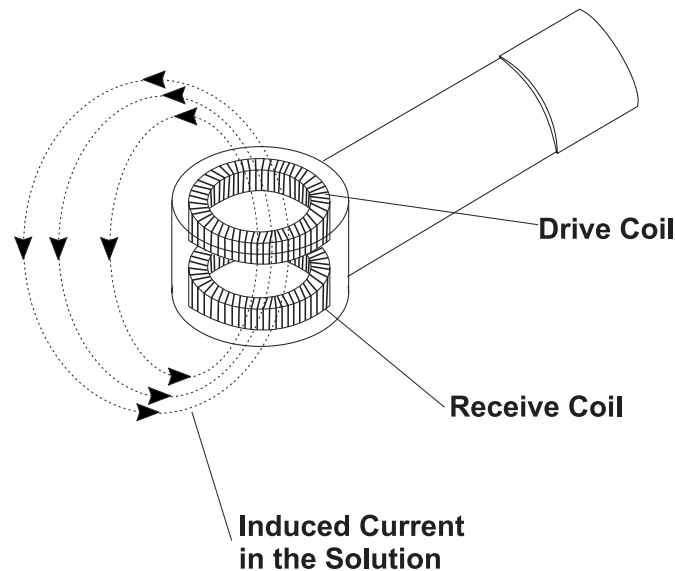

For an inductive cell, the cell constant is defined as the measured conductivity, obtained by making a loop through the sensor with a resistor R, multiplied by that R value.

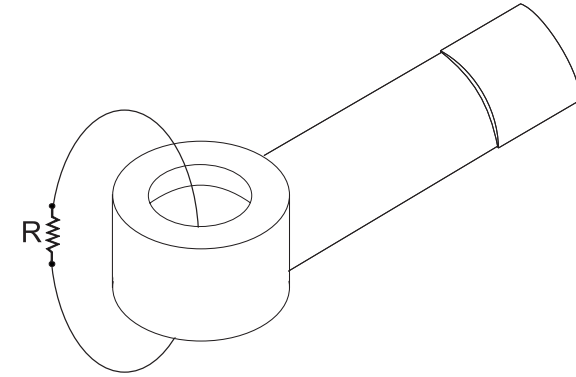

The cell constant depends only on the sensor geometry. However, when the probe is immersed in a liquid, the induced current in the solution is affected by the piping or any other container where the probe is inserted. This effect is negligible when there is an area of at list 3 cm of liquid around the cell.

Otherwise, it is necessary to multiply measurements by the installation factor:

$$\text{Conductivity} = (\text{cell constant})(\text{installation factor})/(\text{measured resistance})$$

The installation factor is < 1 for conductive piping/containers, and > 1 for non-conductive piping/containers.

Since this type of sensor has no electrodes, common problems due to the electrode contact, such as polarization and contamination, will not affect the performance of our electrodeless sensor.

The probe working life is extremely long and the sensor maintenance will be an exceptional operation.

The controllers are equipped with a graphic display, easy to understand as your cellular phone. Simple messages guide the users through all operations and parameter setting.

The main features of the **HI 720** controller series include:

- Measurement and control of conductivity or concentration
- Concentration can be measured as usual TDS (fixed ratio) or through custom conductivity/temperature/concentration curves
- Customizing temperature coefficient table and NaCl temperature compensation according to IEC 746-3, in addition to the standard linear compensation
- Auto-ranging
- Display reading offset adjustment for temperature
- Temperature level alarm
- Cleaning in place activated through two cleaning commands, or triggered by a variety of events
- Hold management, including a digital input to enter the hold mode through an external trigger
- Conductivity probe check
- Digital transmitter input
- Pt100 or Pt1000 temperature sensor with automatic recognition and damage test
- Calibration time-out
- Logging of the last 100 error, configuration and cleaning events
- Alarm fault current (3.6 mA or 22 mA)
- SMS messages sending
- Alarm configuration can be customized: different errors can lead different actions (alarm relay activation, fault current, hold mode, automatic cleaning, SMS message)
- RS485 communication with additional capabilities, such as error log file downloading and cleaning commands
- Daily programmable control timing
- Diagnostic features
- Password protection

SPECIFICATIONS

Range	0 to 2000 mS/cm (auto-ranging) -30 to 130°C / -22 to 266°F
Resolution	1 μ S/cm (0 to 1999 μ S/cm) 0.01 mS/cm (2.00 to 19.99 mS/cm) 0.1 mS/cm (20.0 to 199.9 mS/cm) 1 mS/cm (200 to 2000 mS/cm) 0.1°C / 0.2°F
Accuracy	$\pm 2\%$ f.s. (conductivity) / $\pm 0.5^\circ\text{C}$ / $\pm 1^\circ\text{F}$
Typical EMC Deviation	$\pm 2\%$ f.s. (conductivity) / $\pm 0.5^\circ\text{C}$ / $\pm 1^\circ\text{F}$
Temp. Compensation	Automatic or manual, -30 to 130°C
Temperature Probe	3-wire or 2-wire Pt100 or Pt1000 sensor with automatic recognition and damage test
Digital Input	Digital Transmitter, Hold & Advanced Cleaning inputs
Digital Output	1 digital insulated contact closed upon Hold mode
Analog Output	1 or 2 independent outputs; 0-22 mA (configuring as 0-20 mA or 4-20 mA)
Digital Serial Output	RS485
Dosing Relay	1, 2, 3 or 4 electromechanical relays SPDT; 5A-250 Vac, 5A-30 Vdc (resistive load); fuse protected: 5A, 250 V fuse
Alarm Relay	1 electromechanical relay SPDT; 5A-250 Vac, 5A-30 Vdc (resistive load); fuse protected: 5A, 250 V fuse
Installation Category	II
Power Supply	24 Vdc/ac, or 115 Vac or 230 Vac or 100 Vac $\pm 10\%$, 50/60 Hz; fuse protected: 400 mA, 250 V fast fuse
Power Consumption	10 VA
Max Oscillation Frequency	8 MHz
Environment	0 to 50°C (32 to 122°F); RH max 85% non-condensing
Enclosure	Single case 1/2 DIN
Weight	Approx. 1.6 kg (3.5 lb.)

FUNCTIONAL DESCRIPTION

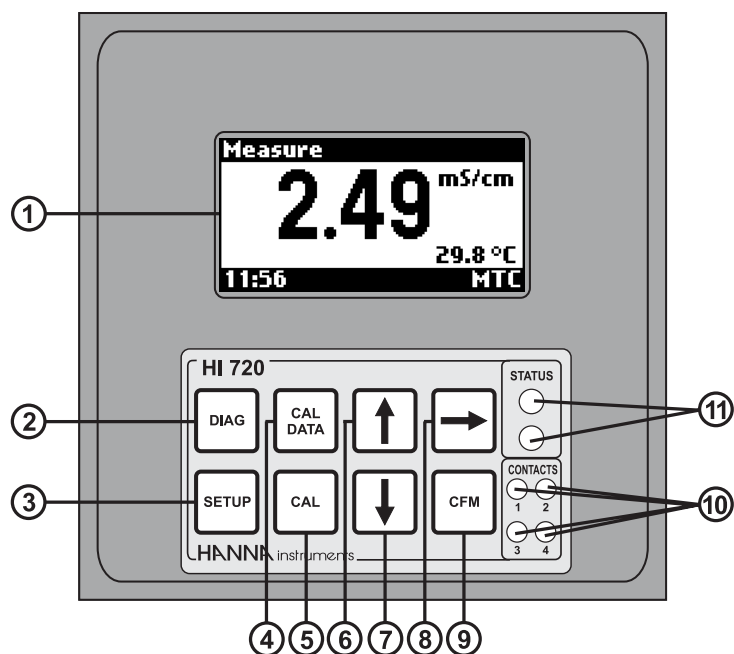

1. Graphic display (128 x 64 dots)
2. **DIAG** key, to enter/exit diagnostic mode; to change the conductivity or concentration range while in setup or calibration mode
3. **SETUP** key, to enter/exit setup mode
4. **CAL DATA** key, to enter/exit last calibration data viewing mode
5. **CAL** key, to enter/exit calibration mode
6. ↑ key, to increase current digit by 1, shift to next option, or move to next record while in diagnostic mode
7. ↓ key, to decrease current digit by 1, shift to previous option, or move to previous record while in diagnostic mode
8. → key, to cyclically change temperature compensation option for conductivity readings: compensation enabled (temperature is continuously displayed) or compensation disabled (actual reading). Only displayed values are affected by this key; control and logging are not affected.
9. **CFM** key, to confirm current choice
10. Contact LEDs, each turns on when the corresponding relay is energized
11. Status (red) and alarm (green) LEDs

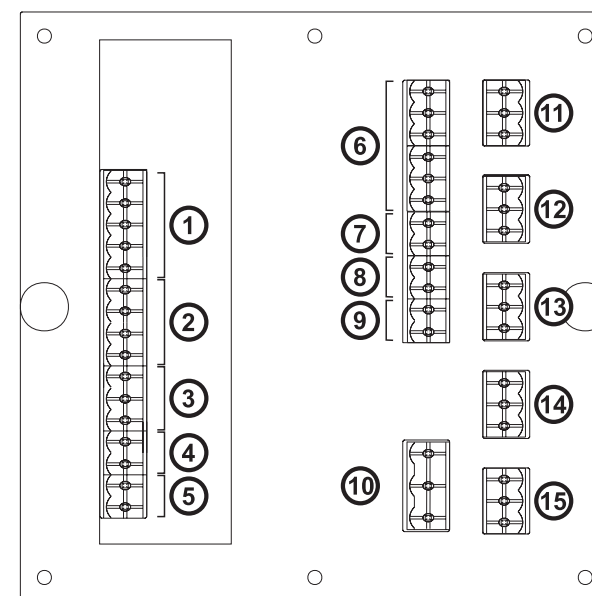

1. Connections for conductivity probe
2. Connections for Pt100/Pt1000 temperature sensor
3. Digital Transmitter input
4. Hold input
5. Advanced Cleaning input (optional)
6. RS485 output terminal
7. Hold output
8. Analog output #1
9. Analog output #2 (optional)
10. Power supply input
11. Relay #3 - for Advanced Cleaning feature (optional)
12. Relay #4 - for Advanced Cleaning feature (optional)
13. Relay #1 - first dosing terminal
14. Relay #2 - second dosing terminal (optional)
15. Alarm relay

INSTALLATION

Mechanical Dimensions

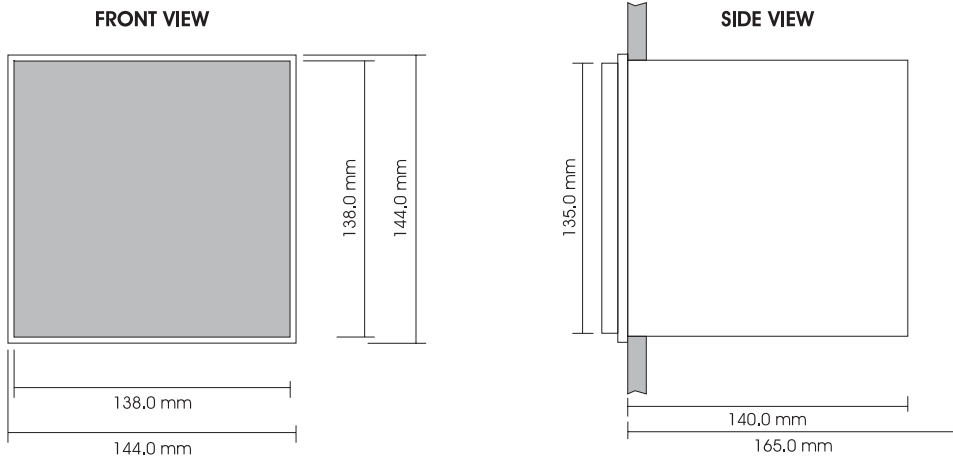

Electrical Connections

- Power Input: connect a 3-wire power cable to the line (L), earth (PE) and neutral (N) terminal connections.
Power: 100 Vac-120 mA / 115 Vac-100 mA / 230 Vac-50 mA.
Line Contact: 400 mA fuse inside.
PE must be connected to ground; leakage current 1 mA.
- Probe Connections (#1 at page 9): connect the Tx and Rx coaxial cables to the relevant terminals, as indicated. Connect the probe cable shield to the "Shield" terminal.
- Pt100/Pt1000 Terminals (#2 at page 9): these contacts connect the Pt100/Pt1000 sensor for automatic temperature compensation.
If the conductivity probe features a built-in Pt100/Pt1000 sensor, connect the related wires to pins 1, 2 and 3; pin 4 will not be used.

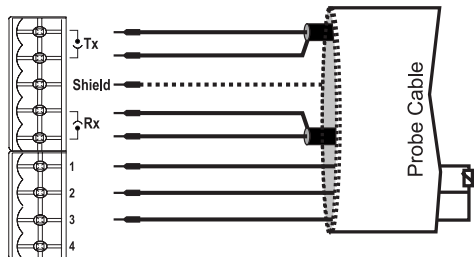
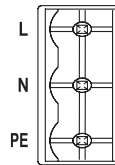

It is also possible to use a separate Pt100/Pt1000 temperature probe. In the case of shielded wire, connect the shield to pin 4. In the case of a 2-wire sensor connect the Pt100/Pt1000 to pins 1 and 3, and short pins 2 and 3 with a jumper wire.

If the Pt100/Pt1000 probe has more than 2 wires, connect the two wires of one end to pins 2 and 3 (pin 2 is an auxiliary input to compensate for the cable resistance) and one wire from the other end to pin 1. Leave the fourth wire unconnected, if present.

Note The instrument automatically recognizes the sensor type (Pt100 or Pt1000).

- Analog Outputs: when using shielded cable, if the shield is not connected at the other end of the cable, then connect it to the "+" terminal, otherwise leave it floating.

Note All cables connected to rear panel should end with cable lugs.

Note A circuit breaker (rated 10 A max.) must be connected in close proximity to the equipment, and in a position easy to reach by the operator, for disconnection of the instrument and all devices connected to the relays.

OPERATIONAL GUIDE

The HI 720 process controller can operate in six main modes:

- Setup mode
- Calibration mode
- Control mode
- Idle mode
- Last calibration data viewing mode
- Diagnostic mode (active errors & event log file scrolling)

All operating modes are described in the following sections.

SETUP MODE

The Setup mode allows the user to set all needed characteristics of the meter. To enter the mode, press the SETUP key and enter the password when the device is in idle or control mode.

If the correct password is not entered, the user can view the setup parameters (except passwords, phone numbers and PIN code), but not modify them (and the device remains in control mode).

Entering the Password

- Press the SETUP key to enter the setup mode. The display will show "0000" (default value), with the first digit highlighted.
- Enter the first digit of the password by using the up & down arrow keys.
- Move to the next digit with the → key and enter the desired value as described above. Continue for the last two digits. When the whole password has been inserted, press CFM to confirm.

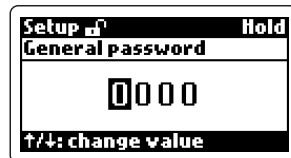

Entering Setup Items

- After the password has been confirmed, the display will show the name of the first setup group (General Setting).
- Using the arrow keys it is possible to cycle through all setup groups, while pressing SETUP will exit the mode, and pressing CFM will confirm the desired selection.
- Once a group is selected, the display shows the first parameter of the group together with its current value.

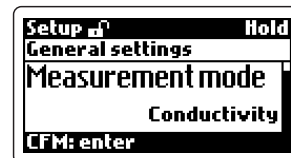
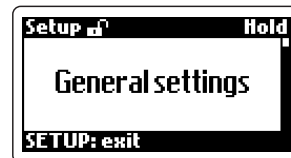

The user can choose the desired parameter with the up & down arrow keys, and confirm the selection by pressing CFM.

Note For some groups, it is necessary to enter several sublevels before choosing a parameter value. Follow the displayed messages to proceed, confirm or exit each screen.

- If a fixed set of values is available for the selected item, use the arrow keys to switch between them. Otherwise, if a numeric value has to be entered, use the arrow keys to change the value of the highlighted digit and cycle through the number's digits.
- Once a value is set, press the CFM key to confirm, and the instrument will turn to the previous screen.

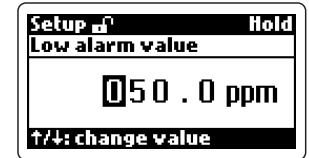
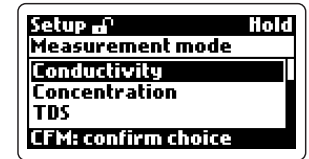

Note After modifying a value in the **concentration curve triplets** or in the **conductivity/temperature couples** for the temperature compensation algorithm, then it is not possible to exit without saving. To return to the previous value, the number must be entered again.

- If a wrong value is confirmed, the "Invalid value!" or "Invalid choice!" message advises the user, the value is not accepted and the instrument will not switch to the next item until a correct value will be confirmed.
- When the last item of the group is reached, by pressing the CFM key again the display will show the group name. The group can then be changed by pressing the up & down arrow keys.

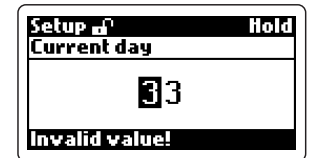

Note If no activity is performed for about 5 minutes after entering the setup mode, the mode is automatically exited and the instrument returns to the previous mode.

This table lists all available setup items together with their code, short description, valid values and default setting.

Setup Item	Description	Valid Values	Default
GENERAL SETTINGS			
G.00	Measurement mode (see note 8)	Conductivity, Concentration, TDS	Conductivity
G.01	Conductivity range	Auto range, 1999 μ S/cm, 19.99 mS/cm, 199.9 mS/cm, 2000 mS/cm	Auto range
G.02	TDS range	Auto range, 1000 ppm, 10.00 ppt, 100.0 ppt, 1000 ppt	Auto range
G.03	Concentration unit (see note 31)	Auto (ppm/ppt), ppm, ppt, %	Auto (ppm/ppt)
G.04	Concentration format	XXXX, XXX.x, XX.xx, X.xxx	XX.xx
G.05	TDS factor	0.00 to 1.00	0.50
G.06	Moving average length (see note 30)	1 to 30	1
G.10	Factory ID	0000 to 9999	0000
G.11	Process ID alias RS485 address	00 to 99	00
G.13	Language	English, Italiano	English
G.14	LCD contrast	0 to 10	6
G.15	LCD backlight	On, Off	On
G.98	Calibration password (see note 2)	0000 to 9999	0000
G.99	General password (see note 2)	0000 to 9999	0000
TEMPERATURE			
b.01	Compensation mode (see notes 7, 20)	Automatic (ATC), Manual (MTC)	ATC
b.02	Start manual temp. (see notes 7, 20)	-30.0 to 130.0°C	25.0°C

Setup Item	Description	Valid Values	Default
TEMPERATURE			
b.03	Temperature measure unit (see note 32)	°C, °F	°C
b.10	Temp. compensation algorithm (note 28)	Linear, NaCl (IEC 746, table BII), User: user defined table	Linear
b.11	Reference temp. (see note 28)	20°C, 25°C	25°C
b.12	Temp. coefficient (see notes 28, 29)	0.00 to 20.00 %	2.00 %
Temperature Compensation Table			
b.31	Number of couples	2 to 10	2
b.32	Edit/view couple	1 to b.31 item value	1
b.33	User table: actual conductivity value for the couple selected in b.32	0 to f.s.	see note 33
b.34	User table: temperature value for the couple selected in b.32	-30.0 to 130.0°C	see note 33
Temperature Level Alarm (see Note 36)			
b.41	Max temperature	-30.0 to 130.0°C	130.0°C
b.42	Min temperature	-30.0 to 130.0°C	-30.0°C
Reading Offset			
b.50	Actual reading (for ATC only, see notes 15, 20)	measurement -10.0°C to measurement +10.0°C	measurement (see note 15)
b.51	Temperature offset (ATC only, notes 15, 20)	-10.0°C to +10.0°C	0.0°C
CONCENTRATION			
d.00	Concentration curve in use	1 to 4	1
Curve 1/2/3/4 Table (see note 34)			
d.01	Number of triplets	1 to 25	1
d.02	Edit/view triplet	1 to d.01 value	1

Setup Item	Description	Valid Values	Default
Curve 1/2/3/4 Table (see note 34)			
d.03	Not compensated conductivity value for the triplet selected in d.02	0 to f.s.	0 $\mu\text{S}/\text{cm}$
d.04	Temperature value for the d.02 triplet	-30.0 to 130.0°C	0.0°C
d..05	Concentration value for the d.02 triplet	0 to f.s.	0 ppm
CONTROL			
C.00	Control enable	On, Off	Off
Setpoint 1			
C.10	Setpoint 1 mode (M1) (see note 1)	Disabled, On/Off high, On/Off low, PID high (if available), PID low (if available)	On/Off low
C.11	Setpoint 1 value (S1)	0 to f.s. (see note 1)	500 $\mu\text{S}/\text{cm}$
C.12	Setpoint 1 hysteresis (H1)	0 to f.s. (see note 1)	20 $\mu\text{S}/\text{cm}$
C.13	Setpoint 1 deviation (D1)	Up to f.s and $\neq 0$ (see note 1)	20 $\mu\text{S}/\text{cm}$
C.14	Setpoint 1 reset time	0.1 to 999.9 minutes	999.9 min.
C.15	Setpoint 1 rate time	0.0 to 999.9 minutes	0.0 min.
Setpoint 2			
C.20	Setpoint 2 mode (M2) (see note 1)	Disabled, On/Off high, On/off low, PID high (if available), PID low (if available)	On/Off low
C.21	Setpoint 2 value (S2)	0 to f.s. (see note 1)	1500 $\mu\text{S}/\text{cm}$
C.22	Setpoint 2 hysteresis (H2)	0 to f.s. (see note 1)	20 $\mu\text{S}/\text{cm}$
C.23	Setpoint 2 deviation (D2)	Up to f.s and $\neq 0$ (see note 1)	20 $\mu\text{S}/\text{cm}$

Setup Item	Description	Valid Values	Default
Setpoint 2			
C.24	Setpoint 2 reset time	0.1 to 999.9 minutes	999.9 min.
C.25	Setpoint 2 rate time	0.0 to 999.9 minutes	0.0 min.
Alarms			
C.30	Low alarm value (LA) (see note 18)	0 to f.s. (see note 1)	100 $\mu\text{S}/\text{cm}$
C.31	High alarm value (HA) (see note 18)	0 to f.s. (see note 1)	1900 $\mu\text{S}/\text{cm}$
C.32	Max relay ON time (then an alarm is generated)	1 to 60 minutes	60 min.
C.33	Alarm mask time (see notes 18, 27)	00:00 to 30:00 min.	00:30
C.34	Alarm hysteresis (AH) (see note 18)	0 to f.s.	20 $\mu\text{S}/\text{cm}$
Programmable Control			
C.41	Hold time start (note 6)	00:00 to 23:59	00:00
C.42	Hold time stop (note 6)	00:00 to 23:59	00:00
C.51	Monday hold mode	Off: disabled, On: enabled	Off
C.52	Tuesday hold mode	Off: disabled, On: enabled	Off
C.53	Wednesday hold mode	Off: disabled, On: enabled	Off
C.54	Thursday hold mode	Off: disabled, On: enabled	Off
C.55	Friday hold mode	Off: disabled, On: enabled	Off
C.56	Saturday hold mode	Off: disabled, On: enabled	Off
C.57	Sunday hold mode	Off: disabled, On: enabled	Off
Other Parameters			
C.60	Proportional control period (if available)	01:00 to 30:00 min.	05:00 min.

Setup Item	Description	Valid Values	Default
Other Parameters			
C.70	Hold mode end delay	00 to 99 seconds	00 sec
C.80	On/Off control action delay (note 26)	00:00 to 30:00 min.	00:00 min

OUTPUT

Relays

O.01	Relay 1 mode (see notes 16, 17)	Disabled, Control-setpoint 1, Control-setpoint 2, Simple cleaning, Hold mode	Control-setpoint 1
O.02	Relay 2 mode (see notes 16, 17)	Disabled, Control-setpoint 1, Control-setpoint 2, Simple cleaning, Hold mode	Control-setpoint 2
O.03	Relay 3 mode (see notes 12, 16)	Disabled, Simple cleaning, Advanced cleaning, Hold mode	Disabled
O.04	Relay 4 mode (see notes 12, 16)	Disabled, Simple cleaning, Advanced cleaning, Hold mode	Disabled
O.05	Hold digital output	Disabled or Hold mode	Hold mode

Analog Output 1

O.10	Analog output 1 mode (notes 1, 17)	Recorder or Control-setpoint 1	Recorder
O.11	Analog output 1 type	0-20 mA or 4-20 mA	4-20 mA
O.12	Analog output 1 minimum value (O_VARMIN1)	0 to f.s. (O_VARMIN1 ≤ O_VARMAX1 -5% f.s. for O_VARMAX1, O_VARMIN1 ≤ O_HOLD1 ≤ O_VARMAX1)	0 μS/cm

Setup Item	Description	Valid Values	Default
Analog Output 1			
O.13	Analog output 1 maximum value (O_VARMAX1)	0 to f.s. (O_VARMIN1 ≤ O_VARMAX1 -5% f.s. for O_VARMAX1, O_VARMIN1 ≤ O_HOLD1 ≤ O_VARMAX1)	1999 μS/cm
O.14	Analog output 1 hold mode (note 13)	User selected value, Previous value	Previous value
O.15	Analog output 1 hold mode value (O_HOLD1)	0 to f.s. (it must be within the O_VARMIN1 to O_VARMAX1 interval)	1000 μS/cm

Analog Output 2

O.20	Analog output 2 mode (notes 1, 17)	Recorder (temperature), Control-setpoint 2 (conductivity/concentration /temperature)	Recorder
O.21	Analog output 2 type	0-20 mA or 4-20 mA	4-20 mA
O.22	Analog output 2 minimum value (O_VARMIN2)	-30.0 to 130.0°C (O_VARMIN2 ≤ O_VARMAX2 -10°C, O_VARMIN2 ≤ O_HOLD2 ≤ O_VARMAX2)	0.0°C
O.23	Analog output 2 maximum value (O_VARMAX2)	-30.0 to 130.0°C (O_VARMIN2 ≤ O_VARMAX2 -10°C, O_VARMIN2 ≤ O_HOLD2 ≤ O_VARMAX2)	100.0°C
O.24	Analog output 2 hold mode (note 13)	User selected value, Previous value	Previous value
O.25	Analog output 2 hold mode value (O_HOLD2)	-30.0 to 130.0°C (it must be within the O_VARMIN2 to O_VARMAX2 interval)	25.0°C

Setup Item	Description	Valid Values	Default
INPUT			
I.00	Input selection (note 10)	Inductive probe or Digital transmitter	Inductive probe
I.03	Digital transmitter address (active if I.00=Digital transmitter)	00 to 99	00
I.04	Digital transmitter baud rate	1200, 2400, 4800, 9600 or 19200 bps	19200 bps
I.10	Calibration timeout	0 to 12 months	12 months
I.11	Life check (see notes 9, 20)	Disabled, 1 hour, 2 hours, or 4 hours	Disabled
REAL TIME CLOCK (see Note 4)			
r.00	Current day	01 to 31	from RTC
r.01	Current month	01 to 12	from RTC
r.02	Current year	2000 to 2099	from RTC
r.03	Current time	00:00 to 23:59	from RTC
COMMUNICATION			
P.00	Connection type	PC, HI 504900 GSM module, HI 504901 GSM supervisor, HI 504902 Modem	PC
P.01	Baud rate	1200, 2400, 4800, 9600 or 19200 bps	19200 bps
P.02	Call answer enable	On, Off	Off
P.03	Modem country code	Insert the phone country code for the HI 504902 modem (see note 35)	000
P.11	PIN code	0000 to 9999	0000
P.12	Phone number #1 (see note 21)	+ ----- ("Not set" means no number entered)	
P.13	Phone number #2 (see note 21)	+ ----- ("Not set" means no number entered)	

Setup Item	Description	Valid Values	Default
COMMUNICATION			
P.14	Remaining SMS (see note 22)	000 to 200, or 222	100
P.15	Repeated SMS	0 to 5 (see note 23)	2
P.16	SMS delay between messages (see note 24)	05 to 60 minutes	10 minutes
P.17	SIM card expiration day (see note 25)	01 to 31	01
P.18	SIM card expiration month (see note 25)	01 to 31	01
P.19	SIM card expiration year (see note 25)	2000 to 2099	2010
CLEANING			
Simple Cleaning			
L.00	Rinsing time	5 to 99 seconds	20 seconds
L.01	Pause time	10 to 9999 minutes	1440 min.
Advanced Cleaning (see Note 19)			
L.10	Pre-rinsing time	0 to 99 seconds	20 seconds
L.11	Cleaning time	0 to 99 seconds	10 seconds
L.12	Rinsing time	5 to 99 seconds	20 seconds
L.13	Pause time	10 to 9999 minutes	1440 min.
L.14	Minimum pause time	10 to L.13 minutes	10 minutes
L.15	Cleaning trigger	Timer only, External only, Timer and external, Timer masked by external	Timer only
L.16	Repeated cycles no.	0 to 10	0
L.17	Economy cycle no.	0 to 10	0
ERROR CONFIGURATION (see Note 5)			
E.00	High alarm (00)	Alarm relay -----> 22 mA fault current----> 3.6 mA fault current---> Auto cleaning -----> SMS sending ----->	On On Off Off Off

Setup Item	Description	Valid Values	Default
ERROR CONFIGURATION			
E.01	Low alarm (01)	Alarm relay -----> 22 mA fault current----> 3.6 mA fault current---> Auto cleaning -----> SMS sending ----->	On Off On Off Off
E.02	Max relay ON time error (02)	Alarm relay -----> 22 mA fault current----> 3.6 mA fault current---> Auto cleaning -----> SMS sending ----->	On On Off Off Off
E.03	Life check error (03) (see note 9)	Alarm relay -----> 22 mA fault current----> 3.6 mA fault current---> Hold mode -----> Auto cleaning -----> SMS sending ----->	On On Off On Off Off
E.10	Conductivity input overflow (10)	Alarm relay -----> 22 mA fault current----> 3.6 mA fault current---> Hold mode -----> Auto cleaning -----> SMS sending ----->	On On Off Off Off Off
E.12	Calibration timeout (12)	Alarm relay -----> 22 mA fault current----> 3.6 mA fault current---> SMS sending ----->	Off Off Off Off
E.20	Broken temperature probe (20)	Alarm relay -----> 22 mA fault current----> 3.6 mA fault current---> Hold mode -----> SMS sending ----->	On On Off Off Off

Setup Item	Description	Valid Values	Default
ERROR CONFIGURATION			
E.21	Temperature level error (21)	Alarm relay -----> 22 mA fault current----> 3.6 mA fault current---> SMS sending ----->	On On Off Off
E.40	Digital transmitter error (40)	Alarm relay -----> 22 mA fault current----> 3.6 mA fault current---> Hold mode -----> SMS sending ----->	On On Off On Off
E.50	GSM/Modem module error (50)	Alarm relay -----> 22 mA fault current----> 3.6 mA fault current--->	On On Off
E.60	Temp. compensation error (60)	Alarm relay -----> 22 mA fault current----> 3.6 mA fault current---> SMS sending ----->	On On Off Off
E.61	Temperature out of concentration table (61)	Alarm relay -----> 22 mA fault current----> 3.6 mA fault current---> SMS sending ----->	On On Off Off
E.62	Conductivity out of concentration table (62)	Alarm relay -----> 22 mA fault current----> 3.6 mA fault current---> Auto-cleaning -----> SMS sending ----->	On On Off Off Off
E.63	Concentration out of user concentration table (63)	Alarm relay -----> 22 mA fault current----> 3.6 mA fault current---> SMS sending ----->	On On Off Off
E.90	Power reset (90)	Alarm relay -----> 22 mA fault current----> 3.6 mA fault current---> SMS sending ----->	Off On Off Off

Setup Item	Description	Valid Values	Default
ERROR CONFIGURATION			
E.91	EEPROM corruption (91)	Alarm relay -----> On 22 mA fault current----> On 3.6 mA fault current---> Off SMS sending -----> Off	
E.92	Watchdog error (92)	Alarm relay -----> Off 22 mA fault current----> On 3.6 mA fault current---> Off SMS sending -----> Off	
E.99	Level or pulse signal (note 11)	Level or Pulse	Level
TEST			
t.00	Display test		
t.01	Keyboard test		
t.02	EEPROM test		
t.03	Relays and LEDs test		
t.04	Analog output 1 test		
t.05	Analog output 2 test		
t.06	Hold digital input test		
t.07	Advanced cleaning digital input test (WARNING: cleaning actions can be triggered by this input going high during the test. See note 19 for details)		

Setup codes are never displayed by the controller, but they are used to identify each setup item in this instruction manual, and for the RS485 communication protocol (see "Communication" section).

NOTES:

(1) M1 can not be set to "On/Off high" or "On/Off low" if O.10 is set to "Control-setpoint 1" and vice versa.

$0 \leq LA + AH < HA - AH \leq f.s.$

if M1 = "PID high", then $S1 + D1 \leq HA - AH$

if M1 = "PID low", then $S1 - D1 \geq LA + AH$

if M1 = "On/Off high", then $S1 - H1 \geq LA + AH$

if M1 = "On/Off low", then $S1 + H1 \leq HA - AH$

M2 can not be set to "On/Off high" or "On/Off low" if O.20 is set to "Control-setpoint 2" and vice versa.

if M2 = "PID high", then $S2 + D2 \leq HA - AH$

if M2 = "PID low", then $S2 - D2 \geq LA + AH$

if M2 = "On/Off high", then $S2 - H2 \geq LA + AH$

if M2 = "On/Off low", then $S2 + H2 \leq HA - AH$

if M1 = "On/Off high" and M2 = "On/Off low", then $S1 - H1 \geq S2 + H2$

if M1 = "On/Off low" and M2 = "On/Off high", then $S2 - H2 \geq S1 + H1$

if M1 = "PID high" and M2 = "On/Off low", then $S1 \geq S2 + H2$

if M1 = "On/Off low" and M2 = "PID high", then $S1 + H1 \leq S2$

if M1 = "PID low" and M2 = "On/Off high", then $S1 \leq S2 - H2$

if M1 = "On/Off high" and M2 = "PID low", then $S1 - H1 \geq S2$

if M1 = "PID high" and M2 = "PID low", then $S1 \geq S2$

if M1 = "PID low" and M2 = "PID high", then $S2 \geq S1$

In addition to the above constraints, in any case, unless M1 = "Off", it must be $LA + AH \leq S1 \leq HA - AH$, and, unless M2 = "Off", it must be $LA + AH \leq S2 \leq HA - AH$. Deviation must be $\neq 0$.

"f.s." (full scale) is the maximum displayed value for the currently configured type of measurement, range and unit.

(2) The calibration password allows calibration and hold mode through the keyboard for service personnel only, while the general password allows any operation (including calibration). Obviously, the general and the calibration/hold passwords can not be viewed among other items when the SETUP key is pressed without entering the right general password. The default general password is "0000". If the user forgets the general password, this can be reset to the default value by pressing CFM+DIAG+CAL DATA simultaneously, while in normal operating mode (idle or control mode). Confirmation is required for the reset; press the up arrow key to confirm the choice.

(3) When a wrong setup code or value is confirmed, the controller does not move from the current window, and displays a blinking WRONG message till the user changes the value. Note that the allowed values for some parameters depend from other settings (e.g. to set a high setpoint to 10.00 mS, first set the high alarm to a value greater than 10.00 mS).

(4) Each time the controller is powered, the RTC is checked to detect if an RTC reset occurred since last software initialization. If that happened, the RTC is initialized with the default date and time (01-01-2000 ; 00:00).

An EEPROM reset does not affect the RTC settings.

(5) The error configuration value is always displayed together with each error configuration item, and is coded as shown on this table

Error Config.	Alarm Relay	22 mA fault curr.	3.6 mA fault curr.	Hold mode	Auto-cleaning	SMS sending
00	OFF	OFF	OFF	OFF	OFF	OFF
01	ON	OFF	OFF	OFF	OFF	OFF
02	OFF	ON	OFF	OFF	OFF	OFF
03	ON	ON	OFF	OFF	OFF	OFF
04	OFF	OFF	ON	OFF	OFF	OFF
05	ON	OFF	ON	OFF	OFF	OFF
06	OFF	OFF	OFF	ON	OFF	OFF
07	ON	OFF	OFF	ON	OFF	OFF
08	OFF	ON	OFF	ON	OFF	OFF
09	ON	ON	OFF	ON	OFF	OFF
10	OFF	OFF	ON	ON	OFF	OFF
11	ON	OFF	ON	ON	OFF	OFF
12	OFF	OFF	OFF	OFF	ON	OFF
13	ON	OFF	OFF	OFF	ON	OFF
14	OFF	ON	OFF	OFF	ON	OFF
15	ON	ON	OFF	OFF	ON	OFF
16	OFF	OFF	ON	OFF	ON	OFF
17	ON	OFF	ON	OFF	ON	OFF
18	OFF	OFF	OFF	ON	ON	OFF
19	ON	OFF	OFF	ON	ON	OFF
20	OFF	ON	OFF	ON	ON	OFF
21	ON	ON	OFF	ON	ON	OFF

Error Config.	Alarm Relay	22 mA fault curr.	3.6 mA fault curr.	Hold mode	Auto-cleaning	SMS sending
22	OFF	OFF	ON	ON	ON	OFF
23	ON	OFF	ON	ON	ON	OFF
24	OFF	OFF	OFF	OFF	OFF	ON
25	ON	OFF	OFF	OFF	OFF	ON
26	OFF	ON	OFF	OFF	OFF	ON
27	ON	ON	OFF	OFF	OFF	ON
28	OFF	OFF	ON	OFF	OFF	ON
29	ON	OFF	ON	OFF	OFF	ON
30	OFF	OFF	OFF	ON	OFF	ON
31	ON	OFF	OFF	ON	OFF	ON
32	OFF	ON	OFF	ON	OFF	ON
33	ON	ON	OFF	ON	OFF	ON
34	OFF	OFF	ON	ON	OFF	ON
35	ON	OFF	ON	ON	OFF	ON
36	OFF	OFF	OFF	OFF	ON	ON
37	ON	OFF	OFF	OFF	ON	ON
38	OFF	ON	OFF	OFF	ON	ON
39	ON	ON	OFF	OFF	ON	ON
40	OFF	OFF	ON	OFF	ON	ON
41	ON	OFF	ON	OFF	ON	ON
42	OFF	OFF	OFF	ON	ON	ON
43	ON	OFF	OFF	ON	ON	ON
44	OFF	ON	OFF	ON	ON	ON
45	ON	ON	OFF	ON	ON	ON
46	OFF	OFF	ON	ON	ON	ON
47	ON	OFF	ON	ON	ON	ON

Note that the values in this table are used for error configuration through RS485.

(6) The hold mode is never enabled by the control timing if the “hold time start” is the same as the “hold time end”. Items C.41 and C.42 apply to all days. The hold mode can be enabled all day long by using items C.51 to C.57.

(7) See “Temperature Compensation” section for more details about Automatic and Manual temperature compensation functioning.

(8) Whenever the measurement type (G.00) is changed, all conductivity and

TDS values in setup (excluding the temperature compensation table and the concentration curves) are automatically updated, so that the "new value / new f.s." = "previous value / previous f.s."

(9) A life check error is generated if the reading does not vary more than 0.5% of the current f.s. within the time period selected through the "life check time" setup item.

(10) When a Digital Transmitter is used, temperature and conductivity are measured by the transmitter, and sent to the process controller. The calibration data set for the digital transmitter is separated from the one regarding the inductive probe input. This means that the calibration data is automatically switched from inductive probe set to digital transmitter set, and vice versa, each time the measurement input is changed from "Inductive probe" to "Digital transmitter", and vice versa. For example, if measurements are performed with an inductive probe directly connected to the controller, then through a transmitter, and again with the direct probe, it is not necessary to re-calibrate the conductivity input.

(11) The alarm relay can be energized continuously (by selecting "Level" option) or with a pulse (by selecting "Pulse" option). The pulse span is fixed at approximately 5 seconds.

(12) Both relays 3 and 4 must be set to "Advanced cleaning" for enabling the advanced cleaning feature. If only one of them is set to "Advanced cleaning", it will behave as if it were set to "Off". Once the advanced cleaning is enabled, relay 3 is used for water pouring and relay 4 for detergent pouring.

(13) "Previous value" and "User selected value" are effective only when items O.10 and O.20 are set to "Recorder", otherwise the analog output is automatically set to the minimum value upon hold mode (i.e. items O.14 & O.15, O.24 & O.25 have no effect if O.10 = Control-setpoint 1 and O.20 = Control-setpoint 2, respectively).

(14) "Measured value" is the reading with no reading offset adjustment.

(15) If the device is set for MTC, items b.50 and b.51 can not be modified nor viewed. When setup item b.01 is changed from ATC to MTC, item b.11 is automatically zeroed.

(16) When relays set to "Simple cleaning" are all changed to another option, the simple cleaning action in progress, is aborted immediately. When relay 3, relay 4 or both of them are set to an option different from "Advanced cleaning", the cleaning action in progress, is aborted immediately, but a complete rinsing is always performed before the actual end of the advanced cleaning session.

(17) If the relay 1 (or relay 2) mode is set to "Control-setpoint 1", the analog output 1 can not be set to "Control-setpoint 1", and vice versa. Similarly, if the relay 1 (or relay 2) mode is set to "Control-setpoint 2", the analog output 2 can not be set to "Control-setpoint 2", and vice versa.

(18) The alarm turns off only when the alarm hysteresis (setup item C.34) has been passed. For high alarm, the alarm turns off below "high alarm - hysteresis", while for low alarm, the alarm turns off above "low alarm + hysteresis").

(19) The actual start of a cleaning action depends on the configuration of relay 3, relay 4 and advanced cleaning parameters.

(20) When using the digital transmitter, this item is not visible, and the corresponding digital transmitter setting is used.

(21) An SMS will be sent to this telephone number when an error configured for SMS sending, occurs. No SMS will be sent if no number has been entered.

(22) This item states the maximum number of SMSs that the meter can send. Before this number reaches 0, a warning message will be sent to the programmed telephone numbers (items P.12 and P.13). This function has been introduced for avoiding the discharge of the SIM card credit. Once all available messages have been sent, the user should extract the SIM card from the GSM module and check remaining credit and expiration date.

The item always shows the remaining number of SMSs. This value is obviously decremented at each SMS submission.

If this item is set to "222", no check will be done and the instrument can send an unlimited number of messages. The item value will not be decremented upon SMS sending, and the SIM expiration date will not be checked.

(23) Each SMS sent by the instrument requires a confirmation phone call. If this confirmation does not arrive, it is possible to set the instrument for repeated message sending. The maximum number of repeated messages is set through this setup item, while the delay between to subsequent messages is set through the item P.16. If the repeated message number is set to 0, then no receiving confirmation is needed.

(24) The delay between two subsequent messages acts only if P.15 ≠ 0.

(25) The SIM expiration date has to be entered manually through items P.17 to P.19. The user should update these values at each card recharge. Three warning messages are sent to the programmed telephone numbers (items P.12 and P.13) to advise the user that the card is expiring (two weeks before, one week before and one day before the expiration date).

If the item P.14 has been set to "222", no expiration date check will be done.

(26) This item is particularly useful in noisy environment, to filter measurement spikes and avoid undesired activations of the on/off control contacts. The relay energizes and de-energizes only if the corresponding threshold is overridden for more than the configured contact action delay (see below graph: "dly" is the contact action delay; relays are energized and de-energized at times $t_n + dly$).

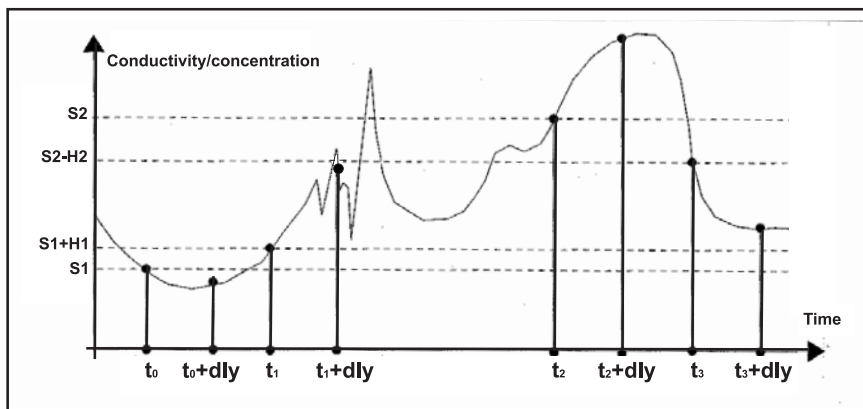

(27) The alarm mask time specifies for how long the conductivity/concentration/temperature value must remain outside the alarm thresholds before an alarm is actually generated. Note that the conductivity/concentration/temperature value must return within the alarm thresholds and remain stable for the same time, before the device can close the alarm.

(28) The **linear temperature compensation** is performed according to the following formula:

$$\text{Compensated conductivity} = \text{Actual conductivity} / [1 + \beta(T - T_{ref})/100]$$

where T is the measured temperature

and Tref is the reference temperature (20 or 25°C).

The temperature coefficient must be manually adjusted by the user when changing the reference temperature. If β is the coefficient with Tref=25°C, the α coefficient with Tref=20°C must be calculated as follows: $\alpha = \beta / (1 - \beta/20)$.

For example, if $\beta = 1.90 \text{ } \%/^{\circ}\text{C}$, then $\alpha = 2.10 \text{ } \%/^{\circ}\text{C}$.

For the NaCl temperature compensation algorithm, the compensation formula is the same as for the linear method, but with β depending on the temperature value according to the IEC 746-3 BII table (also see the "Temperature Compensation" section).

(29) The temperature coefficient can always be viewed and modified, but the set value is used only if the linear compensation method is selected.

(30) This parameter set the number of latest measurements used to calculate an average value. The average is calculated both for conductivity/concentration and temperature. The averaged conductivity/concentration value is then used both for displaying and control.

(31) When the concentration unit is changed, all items from C.00 to C.34 and from O.12 to O.15 are reset to the default values.

(32) The degree Fahrenheit unit is used only for displaying the temperature while in normal measurement mode.

(33) The default values for the temperature compensation table are:

Couple	Actual Conductivity	Temperature
1	500 $\mu\text{S/cm}$	0.0 °C
2	600 $\mu\text{S/cm}$	5.0 °C
3	700 $\mu\text{S/cm}$	10.0 °C
4	800 $\mu\text{S/cm}$	15.0 °C
5	900 $\mu\text{S/cm}$	20.0 °C
6	1000 $\mu\text{S/cm}$	25.0 °C
7	1100 $\mu\text{S/cm}$	30.0 °C
8	1200 $\mu\text{S/cm}$	35.0 °C
9	1300 $\mu\text{S/cm}$	40.0 °C
10	1400 $\mu\text{S/cm}$	45.0 °C

(34) When setting/reading the concentration tables via RS485, use the setup item d.06 to specify the edit/view table (values are 1, 2, 3, 4).

(35) The **HI 504902** modem module is certified by Telecom to work in the following countries: Argentina, Australia, Austria, Belgium, Brazil, Canada, Chile, China, Cyprus, Czech Republic, Denmark, Finland, France, Germany, Greece, Hong Kong, Hungary, Iceland, India, Indonesia, Ireland, Israel, Italy, Japan, Korea, Liechtenstein, Luxembourg, Malaysia, Mexico, Netherlands, New Zeland, Norway, Philippines, Poland, Portugal, Russia, Singapore, Slovak Republic, South Africa, Spain, Sweden, Switzerland, Taiwan, Turkey, United Kingdom, United States.

If your country is not present in the list, please contact your Hanna dealer.

If the country code is shorter than 3 digits, fill the code with zeros in front.

(36) There is a fixed 0.3°C hysteresis for the temperature levels.

CALIBRATION MODE

The controller is factory calibrated for temperature as well as for the analog outputs. The user should periodically calibrate the instrument for the conductivity range.

For greatest accuracy, it is recommended to standardize the probe with a calibration solution close to the expected sample value.

- While in idle or control mode, press the CAL key to enter the calibration mode and the meter will ask for password. Either the general or the calibration password can be used to enter the mode.
- Once confirmed the correct password, the display will show the first available calibration, and the user can scroll through all available procedures by using the up & down arrow keys.
 - Conductivity cell constant
 - Conductivity air offset
 - Conductivity installation factor
 - Temperature, Pt100 or Pt1000 sensor
 - Analog output 1 and Analog output 2
- Press CFM to enter the desired calibration procedure, or CAL to exit.

Conductivity Cell Constant Calibration

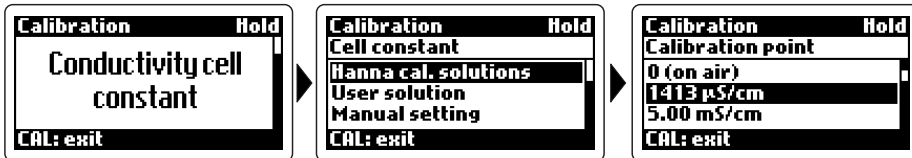

- Once entered the conductivity cell constant calibration, it is possible to choose the calibration point from among 5 memorized Hanna standard solutions (1413 $\mu\text{S}/\text{cm}$, 5.00 mS/cm , 12.88 mS/cm , 80.0 mS/cm , 111.8 mS/cm), enter a custom value (“User solution” for 1 point procedure), or the conductivity cell constant (“Manual setting” option).
- If one of the Hanna memorized standards is confirmed, the instrument will ask if “zero” calibration (i.e. air offset) is also desired.
- If no, confirm the “No” option and proceed with the selected calibration solution. If yes, leave the probe in air, while making sure it is dry, and confirm the “Yes” option. The instrument will start the

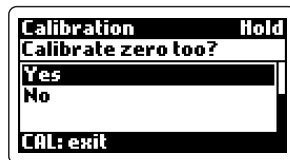

zero calibration, and the “Wait ...” message will flash on the LCD. After completing the procedure, the meter will ask for confirmation to proceed with the previously selected calibration point.

- Press CFM to confirm and immerse the conductivity probe & temperature sensor (if a separate temperature probe is used) in the proper calibration solution. Otherwise, press CAL to exit without saving.
- Wait until the instrument ask for confirmation. Press CFM to confirm or CAL to exit without saving the calibration.
- If the probe is immersed in a wrong solution the “Invalid input!” message will warn the user.

Conductivity Air Offset Calibration

This mode allows the user to calibrate the zero point only.

- Leave the probe in air, while making sure it is dry, and confirm the selection. The meter will automatically perform the calibration and ask for confirmation.
- Press CFM to save the air offset calibration, or CAL to exit without any updating.

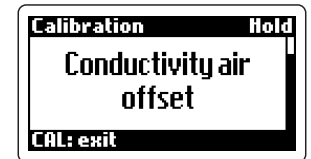

Conductivity Installation Factor Calibration

This procedure follows the same steps as the conductivity cell constant calibration (see related paragraph for details), and allows to adjust the probe/instrument system to each particular installation.

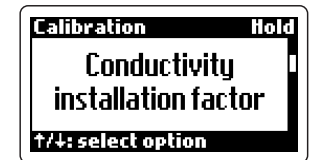

Temperature Calibration (Pt100 or Pt1000 sensor)

The controller is factory calibrated for temperature. However, the user can perform a 2-point calibration procedure.

- The instrument can support Pt100 or Pt1000 temperature sensor. Choose the corresponding calibration option with the up & down arrow keys.

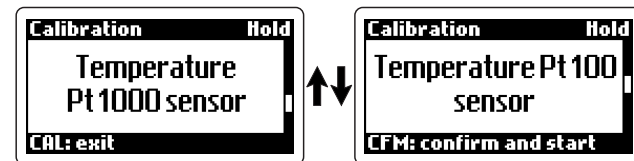

- The first calibration point is 0°C, while the second one can be selected between 25 and 50°C.
- Prepare an ice bath at 0°C by mixing crushed ice and water, and a beaker containing hot water at 25 or 50°C.

- Use a *Checktemp* or another calibrated thermometer with a resolution of 0.1° as reference thermometer, and immerse the temperature sensor in the ice bath as near to the *Checktemp* as possible.
- Confirm the calibration option and the instrument will start the automatic calibration of the first point.
- When the reading becomes stable, the instrument will ask confirmation.
- Press CFM to confirm and proceed with the second point, or CAL to exit without saving.
- Select the desired value for the second point (25°C or 50°C) by using the up & down arrow keys. Immerse the temperature sensor in the proper temperature bath as near to the *Checktemp* as possible, confirm the desired calibration point and the instrument will start the automatic calibration of the 2nd point.
- When the procedure is completed, the meter will ask for confirmation. Press CFM to save the calibration, or CAL to exit without any updating.

Analog Output Calibration (Analog Outputs 1 & 2)

The instrument can be provided with one or two analog outputs, each of them can be calibrated at 2 points (4 and 20 mA).

- Connect an Ammeter or the **HI 931002** tester to the analog output to measure the current erogated by the meter.
- Select the desired calibration mode by using the up & down arrow keys, and confirm the choice by pressing CFM. The instrument will show the first calibration value (4 mA).

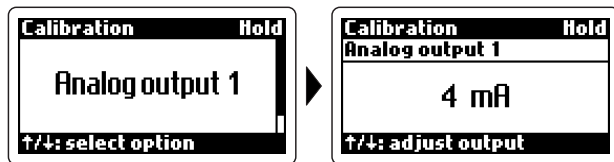

- With the tester check the real current value provided by the instrument at the output port. If this value is different from the expected one, adjust it with the up & down arrow keys, until it matches with the first calibration point. To increase the adjustment speed when the displayed value is far from the calibration one, press and hold the arrow keys.
- Press CFM to confirm and turn to the second calibration point (20 mA), then proceed as for the first point.
- Press CFM to save the calibration, or CAL to exit without any updating.

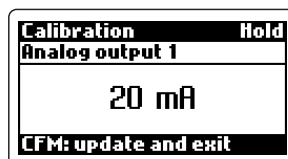

CONTROL MODE

The control mode is the normal operational mode for this meter. During control mode **HI 720** fulfills the following main tasks:

- convert information from conductivity and temperature inputs to digital values, and show them on the display
- control relays and generate the analog outputs as determined by the setup configuration
- display alarm condition
- perform cleaning actions according to the relay configuration
- start & stop hold mode according to the programmed control timing
- RS485 management

In addition, the meter can log working data. These data include:

- conductivity and °C measured values
- last calibration data
- setup configuration
- event data

While in control mode, in a normal situation, the green LED is ON and the red (error) LED is OFF. The red LED is never fixed ON, and blinks only upon an error. The green LED is associated to the alarm relay and is OFF if the alarm is active. To disable the control mode, set the "Control Enable" setup item to "OFF" ("Control" setup group).

Relay Modes

There are four relay options that can be configured through the setup menu to perform different tasks.

Once enabled, relays 1 and 2 can be used in four modes:

1. setpoint 1 (Analog output #1 must be set to "Recorder")
2. setpoint 2 (Analog output #2 must be set to "Recorder")
3. simple cleaning
4. hold mode

If option 1 or 2 is selected, the setpoint configuration determines the relay operating mode. Once enabled, the relay can be configured as a ON/OFF or PID control of the dosage.

An alarm limit is imposed for dosage time when the relays are energized continuously. This parameter can be set through setup procedure ("Control" group, setup item C.32).

When the upper time boundary is reached, an alarm is generated and the device will remain in alarm condition until the relay is de-energized.

If the “hold mode” is selected for the relay, then it is energized only when the meter is in hold mode. In this case there is no time boundary for the relay ON state.

Relays 3 and 4 can be configured to operate in three modes:

1. simple cleaning
2. advanced cleaning
3. hold mode

ON/OFF Control Mode

Once a relay is enabled (set 1, set 2), the setpoint can be configured to be activated as a high (“OOHI”) or low limit (“OOLO”). In both cases the following values have to be defined through setup:

- setpoint value (conductivity value; setup item C.11 or C.21)
- hysteresis for setpoint (conductivity value; setup item C.12 or C.22)

A control device can be wired to the contact output: connect the device to the COM and NO (Normally Open) or NC (Normally Closed) terminals of the relay. The ON relay state occurs when the relay is energized (NO and COM connected, NC and COM not connected), while the OFF state occurs when the relay is de-energized (NO and COM not connected, NC and COM connected). When measurement exceeds the setpoint threshold, a relay enabled as high setpoint is energized until the reading falls below the setpoint minus hysteresis. When the measured value is below the setpoint, a relay enabled as low setpoint is energized until the reading goes above the setpoint plus hysteresis.

PI.D. Control Mode

PID control is designed to eliminate the cycling associated with ON/OFF control in a rapid and steady way by combining the Proportional, Integral and Derivative control methods.

Using the proportional function, the activated control lasts for a time period proportional to the error value (Duty Cycle Control Mode); as measurement approaches the setpoint, the ON (relay energized) period diminishes.

During proportional control, the instrument calculates the relay activation time at certain moments t_0 , $t_0 + T_c$, $t_0 + 2T_c$ etc.

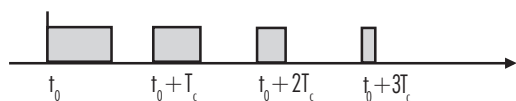

The ON interval (shaded areas) then depends on the error amplitude.

Using the integral function (reset), the controller reaches a more stable output around the setpoint providing a more accurate control than the ON/OFF or proportional action only.

The derivative function (rate action) compensates for rapid changes in the system, and reduces undershoot & overshoot of the conductivity value.

During PID control, the ON interval depends not only on the error amplitude but even on the previous measurements.

Definitely, PID control provides more accurate and stable control than ON/OFF controllers, and it is the ideal solution in system with a fast response, quickly reacting to changes in the controlled solution.

PI.D. Transfer Function

The transfer function of a PID control is given by the following relation:

$$K_p + K_i/s + s K_d = K_p(1 + 1/(s T_i) + s T_d)$$

where $T_i = K_p/K_i$ and $T_d = K_d/K_p$,

The first term represents the proportional action, the second is the integrative action and the third is the derivative action.

Proportional action can be set through the Proportional Band (PB), expressed as input range percentage, and related to K_p :

$$K_p = 100/PB$$

The proportional action is set directly as “Deviation” (D) in conductivity units, with the following relation:

$$D = \text{Range} * PB/100$$

Each setpoint has a selectable proportional band: PB1 for setpoint1 and PB2 for setpoint2. Two further parameters must be provided for both setpoints:

$T_i = K_p/K_i$, reset time, measured in minutes

$T_d = K_d/K_p$, rate time, measured in minutes

T_{i1} and T_{d1} will be the reset and rate times for setpoint1, while T_{i2} and T_{d2} will be the reset and rate times for setpoint2.

Tuning a PI.D. Controller

The proportional, integrative, derivative terms must be tuned, i.e. adjusted to a particular process. Since usually the process variables are not completely known, a “trial & error” tuning procedure must be applied to get the best possible control for each process.

The target is to achieve a fast response time and a small overshoot. Many tuning procedures are available and can be applied to **HI 720**.

A simple and profitable procedure is described in this manual and can be used in almost all applications.

The user can vary five different parameters, i.e. setpoint value (S1 or S2), deviation (D1 or D2), reset time, rate time and proportional control mode period T_c .

Note The user can disable the derivative and/or integrative action (for P or PI controllers) by setting $T_d = 0$ and/or $T_i = \text{MAX}(T_i)$, respectively, through the setup procedure.

Simple Tuning Procedure

The following procedure uses a graphical technique for analyzing a process response curve to a step input.

Note This procedure allows only a rough setting of the PID parameters and could not fit all processes. It is suggested that I and D parameters be set by technical personnel, because their inadequate values may cause undesired behaviors of the system.

Note Connect an external device (chart recorder or PC) to the controller and the procedure will be easier, without requiring hand plotting of the process variable.

1. Start from a solution with a conductivity value different from the dosed liquid (the difference should be at least 15% of the full scale), and turn on the dosing device at its maximum capacity without the controller in the loop (open loop process). Note the starting time.
2. The conductivity value will vary and reach a maximum rate of change (slope). Note the time at which this maximum slope occurs and the corresponding conductivity value. Note the maximum slope per minute. Turn the system power off.
3. On the chart, draw a tangent to the maximum slope point. Then read on the time axis the system time delay (T_x), i.e. the time value corresponding to the intersection between the drawn tangent and the starting conductivity value.
4. The deviation, T_i and T_d , can be calculated as follows:
 - Deviation = $T_x \cdot \text{max. slope}$
 - $T_i = T_x / 0.4$ (minutes)
 - $T_d = T_x \cdot 0.4$ (minutes)
5. Set the above parameters, put the controller in the loop and restart the system. If the response has too much overshoot or is oscillating, fine tune the system by slightly increasing or decreasing the PID parameters one by one.

Example:

- Max. slope = $30 \text{ mS} / 5 \text{ min} = 6 \text{ mS/min}$
- Time delay = $T_x = \text{approx. } 7 \text{ minutes}$
- Deviation = $T_x \cdot 6 = 42 \text{ mS}$
- $T_i = T_x / 0.4 = 17.5 \text{ min}$
- $T_d = T_x \cdot 0.4 = 2.8 \text{ min}$

Alarm Relay

During normal operation (no alarm condition) the alarm relay is energized, while during an alarm condition or power failure the relay will be de-energized. As long as a separate battery power system is used, an alarm will sound.

Example:

High alarm set at 1200 mS

Low alarm set at 400 mS

When the measurement is close to an alarm value, the hysteresis will eliminate the continuous relay energizing/de-energizing sequence. The hysteresis amplitude is user-selectable.

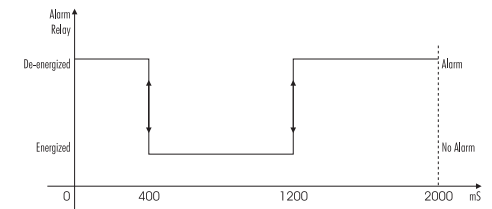

Moreover, the alarm signal is generated only after the user selectable time period (alarm mask) has elapsed since the controlled value has overtaken one alarm threshold. This additional feature will avoid fake or temporary alarm conditions.

Note If the power supply is interrupted, the relay is de-energized as in alarm condition to alert the operator.

In addition to the customizing alarm relay, the meter is equipped with the Fail Safe alarm feature.

The Fail Safe feature protects the process against critical errors arising from power interruptions, surges and human errors. This sophisticated yet easy-to-use system resolves blackout and line failure problems on both hardware and software sides. The alarm function operates in a "Normally Closed" state and hence alarm is triggered if the wires are tripped, or when the power is down. This is a very important feature since with most meters the alarm terminals close only when an anomaly occurs, and no alarm is generated upon line interruption, causing extensive damage. On the other hand, the software is employed to set off the alarm in abnormal circumstances, such as dosing terminals closed for too long. In both cases, the red LED will also provide a visual warning signal.

The Fail Safe mode is accomplished by connecting the external alarm circuit between the FS•C (Normally Open) and the COM terminals. This way, an alarm will warn the user when measurement overtakes the alarm thresholds, power fails, or the wire connecting the process meter with the external alarm circuit breaks.

Note To activate the Fail Safe feature, an external power supply must be connected to the alarm device.

Control through Analog Output

Instead of configuring relays, it is possible to use an output signal (selectable at 0-20 mA or 4-20 mA, and proportional to the PID action) at the analog output terminals.

With this output, the actual output level amplitude varies continuously (with an update delay of 5 seconds) between the maximum and minimum values, rather than varying the proportion of ON and OFF times (duty cycle control). The output signal range can be selected through setup items O.11 (output #1) and O.21 (output #2).

A device provided with analog input (e.g. a pump with a 0-20 mA input) can be connected to these terminals. The analog output #1 is associated to the setpoint #1, and the analog output #2 to the setpoint #2.

For a control through analog output, a setpoint has to be configured to "PidL" or "PidH", and the corresponding output has to be set to "Control" (setup item O.10 for analog output #1, and O.20 for analog output #2). In this case no relay can be associated with the same setpoint being used for the control. On the other hand, if a control through analog output is already associated with a setpoint, it is not possible to configure a relay to the same setpoint.

IDLE MODE

While in idle mode, the device only performs measurements. It does not activate relays or generate a control signal to the analog output(s).

In a normal situation the alarm relay is energized (no alarm condition) and the green LED is ON. The red LED is also fixed ON to warn users the device is not controlling the process, while the yellow LEDs are OFF.

The alarm relay could be de-energized upon an error (whether that happens or not, depends on the customized alarm configuration; see "Alarm" section for details). Nevertheless, the error due to alarm threshold overtaking does never generate an alarm during idle mode since all the control functions have been disabled by the user.

The red LED flashes in any case when an error occurs.

The idle mode is useful to disable control actions when the external devices are not properly settled or whenever any fault circumstance is detected.

LAST CALIBRATION DATA VIEWING MODE

The following data about the last calibration is stored in the EEPROM:

- Date & time of last conductivity calibration
- Calibration point(s)
- Cell constant or installation factor value

To view the last calibration data, press the CAL DATA key. To quit and return to normal operations, press CAL DATA again.

```

Last calibration   Hold
Conductivity calibrated
on 2004-12-02 14:55
with solution: 0, 1413 µS
Cell constant: 3.456
CAL DATA: exit
    
```

```

Last calibration
Conductivity calibrated
on 2004-12-03 16:45
on user point: 9.28 mS
Inst. factor: 3.456
CAL DATA: exit
    
```

```

Last calibration
Conductivity calibrated
on 2004-12-03 16:57
with manual setting
Cell constant: 2.200
CAL DATA: exit
    
```

Note When the "Input selection" item is set to "Digital Transmitter", the last calibration data displayed, refers to the Digital Transmitter and is stored in that device. The calibration data of the process controller is kept in its internal memory and comes back when the "Input selection" item is changed again to "Inductive probe".

DIAGNOSTIC MODE

The diagnostic mode allows the user to check if some errors are still active on the controller, or view the event log file.

To enter (and exit at any time) this mode, press the DIAG key. Select the desired option with the up & down arrow keys, and then confirm the selection by pressing CFM.

Active Errors

This option allows the user to check which errors are active on the controller, and therefore provide proper actions. Each error is displayed together with the corresponding code.

Use the up & down arrow keys to scroll through the complete list, or press DIAG to exit.

If no error is active, the "No error" message will be displayed.

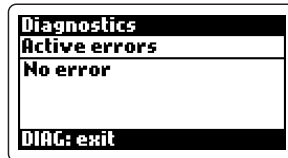
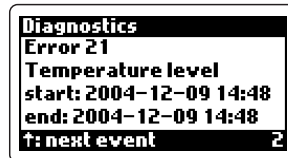
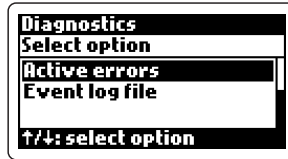

Event Log File

The event log file contains a maximum of 100 recorded events, which include errors, calibration events, configuration changes and cleaning events. Use the up & down arrow keys to scroll through the complete list, or press DIAG to exit.

The event index is displayed on the bottom right corner of the LCD (the oldest event has index 0, while the latest event has the higher index value).

Each record is complete with the following information:

1. Errors: Error code and description, starting date & time, "ACTIVE" indication if the error is still active, or ending date & time if the error is closed.

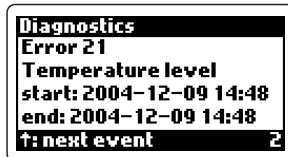
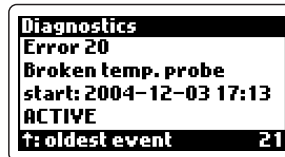

2. Calibration events: type of calibration, date & time, calibration points (if available).

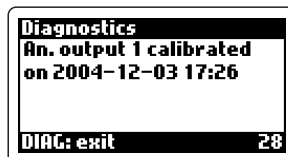

3. Configuration changes: setup group, setup parameter, date & time of the modification, previous value, new value.

If the description of the previous and/or new value is too long to be displayed, an index between square brackets is used. This index indicates the position of the value in the list of available options for the parameter. For example, if the Relay 1 mode is changed from "Control-setpoint 1" to "Control-setpoint 2", the recorded event will be "Control [2]" to "Control [3]", because "Control-setpoint 1" is the second option of the list, while "Control-setpoint 2" is the third.

4. Cleaning events: type of the cleaning action, date & time of the event.

Note The logged event information can be downloaded to a PC through the HI 92500 application software.

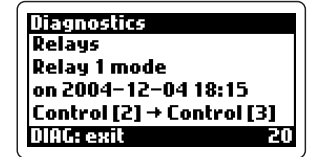
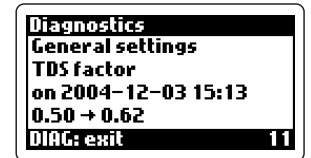

TEMPERATURE COMPENSATION

If the setup item b.01 is set to ATC, then an automatic temperature compensation of the conductivity readings will be performed using the temperature values acquired through the Pt100/Pt1000 input.

If the temperature probe is not connected or it provides an invalid temperature (outside the -30 to 130°C range), the instrument will generate a “broken temperature probe” error, which will be handled as stated in the error configuration. In this case the temperature compensation will be automatically switched to the MTC option. The instrument continues to monitor the Pt100/Pt1000 input to track the Pt100/Pt1000 error closing. When this error is closed, the setup item b.01 will automatically change back to ATC.

If the user set the parameter b.01 to MTC, then a manual temperature compensation will be performed in any case, even if a temperature probe is connected. The user can also select the temperature compensation algorithm through the setup item b.10: Linear, NaCl or User defined table.

Linear Temperature Compensation

The linear temperature compensation is performed according to the following formula:

$$C_{\text{comp}} = C_{\text{act}} / [1 + \beta(T - T_{\text{ref}})/100]$$

where

- C_{comp} is the compensated conductivity value
- C_{act} is the actual conductivity value (not compensated)
- T is the measured temperature
- T_{ref} is the reference temperature (selectable at 20 or 25°C).

The temperature coefficient (β) must be manually adjusted by the user when changing the reference temperature. If β is the coefficient with $T_{\text{ref}}=25^\circ\text{C}$, the α coefficient with $T_{\text{ref}}=20^\circ\text{C}$ must be calculated as follows: $\alpha = \beta / (1 - \beta/20)$.

For example, if $\beta=1.90\text{ } \%/^\circ\text{C}$, then $\alpha = 2.10\text{ } \%/^\circ\text{C}$.

NaCl Temperature Compensation

For the NaCl algorithm, the compensation formula is the same as for the linear method, but with β depending on the temperature value according to the IEC 746-3 BII table. Note that the table reports β values referred to 18°C and the **HI720** adjusts that values according to T_{ref} as follows: $\beta = \beta_{18} / [1 + \beta_{18}(T_{\text{ref}} - 18)]$.

User Defined Table for Temperature Compensation

The compensation formula is the same as for the linear method, but the instrument calculates the temperature coefficient based on the table defined by the user through the setup items b.31 to b.34.

Up to 10 actual conductivity/temperature couples can be entered to define the curve for the temperature compensation.

The default values for the temperature compensation table are:

Couple	Actual Conductivity	Temperature
1	500 $\mu\text{S/cm}$	0.0 $^\circ\text{C}$
2	600 $\mu\text{S/cm}$	5.0 $^\circ\text{C}$
3	700 $\mu\text{S/cm}$	10.0 $^\circ\text{C}$
4	800 $\mu\text{S/cm}$	15.0 $^\circ\text{C}$
5	900 $\mu\text{S/cm}$	20.0 $^\circ\text{C}$
6	1000 $\mu\text{S/cm}$	25.0 $^\circ\text{C}$
7	1100 $\mu\text{S/cm}$	30.0 $^\circ\text{C}$
8	1200 $\mu\text{S/cm}$	35.0 $^\circ\text{C}$
9	1300 $\mu\text{S/cm}$	40.0 $^\circ\text{C}$
10	1400 $\mu\text{S/cm}$	45.0 $^\circ\text{C}$

This table corresponds to a constant $\beta = 2\%/^\circ\text{C}$.

The couples must be entered according to these conditions, otherwise a “Temperature table error!” message is displayed when the “User” option is confirmed for the temperature compensation algorithm:

- if $T_1 < T_2$, then $C_1 < C_2$
- $T_{\text{min}} < T_{\text{ref}} < T_{\text{max}}$
- two subsequent temperatures must differ at least 1°C

Based on the defined table, up to 10 temperature coefficients are automatically computed as follows:

$$\beta_n = (C_n - C(T_{\text{ref}})) / [(T_n - T_{\text{ref}}) * C(T_{\text{ref}})]$$

where $C(T_{\text{ref}})$ is the actual conductivity at T_{ref} , and is computed as follows:

$$C(T_{\text{ref}}) = C_m + (C_{m+1} - C_m) * (T_{\text{ref}} - T_m) / (T_{m+1} - T_m)$$

with $T_m < T_{\text{ref}} < T_{m+1}$

Then, if the current temperature is T , with $T_n \leq T \leq T_{n+1}$, with (C_n, T_n) and (C_{n+1}, T_{n+1}) being two subsequent couples configured in the user table, then the temperature coefficient will be:

$$\beta(T) = \beta_n + (\beta_{n+1} - \beta_n) * (T - T_n) / (T_{n+1} - T_n)$$

When the measured temperature is lower than the minimum temperature in the table (T_1), then the coefficient will be calculated by replacing T with T_1 .

When the measured temperature is greater than the maximum temperature in the table (T_{10}), then the coefficient will be calculated by replacing T with T_{10} .

CONCENTRATION CURVES

The instrument allows the user to insert up to 4 concentration tables, and each table is defined by up to 25 triplets of conductivity (K), temperature (T) and concentration (C) values.

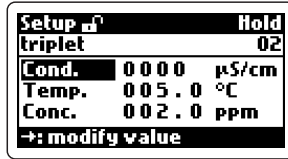

Note that all conductivity values in this section are actual values (i.e. not compensated for temperature variation).

The user-defined concentration table then allows to calculate the concentration from conductivity and temperature values, only if the triplets satisfy the following conditions:

1. The isothermal curves (i.e. conductivity/concentration curves at the same temperature) must be strictly monotonous. Otherwise, when the table is selected, the message "The selected curve is not strictly monotonous!" is displayed.
2. The conductivity values on the same isotherm must differ at least 10 μS. Otherwise, when the table is selected, the message "Invalid conductivity minimum distance in the selected curve!" is displayed.
3. Two subsequent isothermal curves must differ at least 0.5°C. Otherwise, when the table is selected, the message "Invalid temperature minimum distance in the selected curve!" is displayed.
4. It is not possible to use an isotherm including only one triplet (conductivity, temperature, concentration) equal to (0, T_x, 0). Otherwise, when the table is selected, the message "Isotherm with zero-zero value is present in the selected curve!" is displayed.

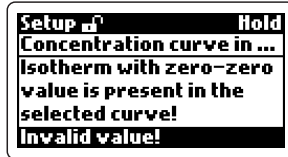
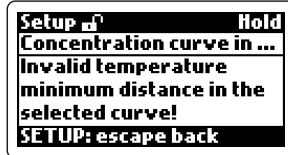
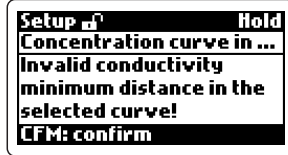
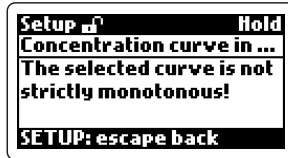

All triplets with the same value for temperature, are used to draw a piecewise-linear isotherm (see diagram on the next page).

The instrument calculates the solution concentration C_x from the measured conductivity K_x at the temperature T_x, by using the following algorithm:

$$C_x = C_L + (C_U - C_L) * (T_x - T_L) / (T_U - T_L)$$

where

- C_L is the concentration corresponding to the conductivity K_L at the temperature T_L, and T_L is the temperature of the isotherm just below the temperature T_x

- C_U is the concentration corresponding to the conductivity K_U at the temperature T_U, and T_U is the temperature of the isotherm just above T_x.

The diagram shows the computational procedure.

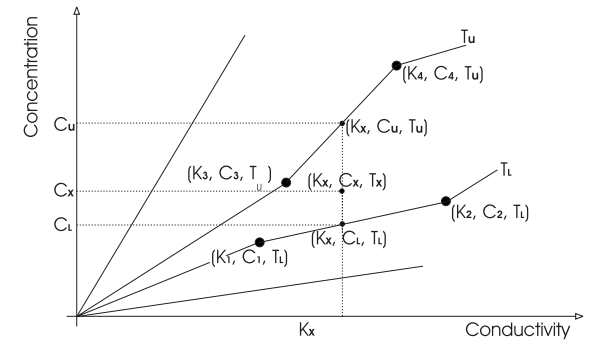

Note If T_x is greater than all temperature values specified for the isotherms, then the concentration value C (K_x, T_{max}) is assigned to C_x (where T_{max} is the maximum temperature for the selected table), and the "Temperature out of conc. table (61)" alarm is generated.

If T_x is lower than all temperature values specified for the isotherms, then the concentration value C (K_x, T_{min}) is assigned to C_x (where T_{min} is the minimum temperature for the selected table), and the "Temperature out of conc. table (61)" alarm is generated.

Note If the calculated concentration is greater or lower than all concentration values specified in the table, the "Concentration out of conc. table (63)" alarm is generated.

Note If the conductivity is greater or lower than all conductivity values specified in the table, the "Conductivity out of conc. table (62)" alarm is generated.

Note If only one point is specified in the table (K₀, T₀, C₀), the concentration values at a given conductivity do not vary with temperature. If the conductivity values changes to K_x, then the concentration C_x is calculated as follows:

$$C_x = K_x * (C_0 / K_0)$$

HOLD MODE

This function is started by:

- calibration
- setup
- cleaning in place
- the hold digital insulated input (there are two digital insulated inputs: one for hold mode and one for the advanced cleaning) when it is on; normally the signal level is polled at least every 4 seconds
- the proper key combination (CFM and up arrow keys together) for service; the same key combination is used both to start and stop the hold mode (the key combination acts in the same way as the hold digital input)
- the daily programmable control timing (see setup items C.41 to C.57)
- an error event (see also the “Alarm - Error Configuration” section)
- the hold start/stop RS485 command

During hold mode, control and control relays are disabled. If the meter is in idle or control mode and displaying measurements, then the last measured value (both for temperature and conductivity/concentration) is frozen on the display. During hold mode, the LCD shows the “Hold” message.

If the conductivity/concentration or temperature values are not available because the meter did not perform any measurement before going in hold mode, then the display shows dashes.

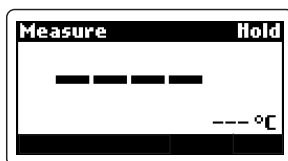

All alarm signals (red LED, alarm relay, fault currents) are suspended while in hold mode (the correspondent errors are not closed), unless the hold mode has been triggered by an error (and no other trigger source is active).

If the hold mode is triggered by an error, and that error is related to measurements (e.g. conductivity input overflow), the instrument continues to measure in order to track the possible error closing, even though the display continues to show the hold value.

The analog output follows these rules:

- If it is configured for control (i.e. setup item O.10 or O.20 has been set to “Control-setpoint 1” or “Control-setpoint 2”, respectively), then its value is set to the minimum (e.g. 4 mA for 4-20 mA input)
- If it is configured for a recorder, then its value is either set to the user selection (setup item O.15 or O.25, with O.14 or O.24 set to “User selected value”) or frozen to the output value just before entering the hold mode (with O.14 or O.24 set to “Previous value”).

After the cause which made the instrument enter the hold mode expires, the device exits the hold mode, but control and alarms remain disabled for a user-selectable delay (0 to 99 seconds). In that situation, measurements are normally acquired, displayed and recorded through the analog or RS485 output.

Note Alarms (alarm relay, red LED, fault currents) are not disabled if the hold mode has been triggered by an error and no other trigger source is active.

IN-LINE CLEANING

The cleaning feature allows an automatic cleaning action of the electrodes. To perform cleaning, the controller activates an external device (pump).

Cleaning actions never take place if no relay is configured for cleaning. Moreover, the Advanced Cleaning requires both relays 3 and 4 to be configured for it.

Cleaning can be of two types:

- **Simple cleaning:** with water only, it can be triggered only by a timer (periodical cleaning) or by an error for which a cleaning action can be configured
- **Advanced cleaning** (optional): with water and detergent, it can be triggered by the following events:
 - timer
 - digital input or RS485 command (external trigger)
 - timer and digital input or RS485 command (external trigger)
 - timer masked by the digital input (i.e. disabled when the digital input is on)
 - error for which a cleaning action can be configured

A minimum pause time can be set to avoid continuous cleaning due to the external trigger. A cleaning action with detergent can be followed by one or more cleaning actions without detergent, if desired.

Note The RS485 command for cleaning triggering must be issued when the minimum pause time has expired, otherwise it has no effect.

Simple cleaning actions are performed in the following sequence:

- **Rinsing time:** the device enters hold mode; all relays configured for simple cleaning are energized. The “Rinsing” message is displayed if the device is in normal measurement mode.
- **Hold mode end delay:** if the device was controlling, then the hold mode end delay must expire before restarting control.

Advanced cleaning actions are performed in the following sequence:

- **Pre-rinsing time:** the device enters hold mode and relay 3 is energized. The “Pre-rinsing” message is displayed if the device is in normal measurement mode.
- **Detergent washing time:** relay 4 is energized and relay 3 continues to be energized. The “Detergent” message is displayed if the device is in normal measurement mode.
- **Rinsing time:** relay 4 is de-energized and relay 3 continues to be energized. The “Rinsing” message is displayed if the device is in normal measurement mode.

- **Hold mode end delay:** if the device was controlling, then the hold mode end delay must expire before restarting control.

If the device is in normal measurement mode, when performing a cleaning action, the display shows a countdown for the seconds remaining to the cleaning action end, and starting with the total cleaning time.

If the advanced cleaning has been set without detergent, the display will show the “No detergent” message (instead of “Detergent”).

If the “Repeated cycles number” (setup item L.16) is different from 0, then the advanced cleaning action, after the first cycle, will be repeated as many times as set in the “Repeated cycles number” (e.g. one more cycle if L.16=1).

Any cleaning action in progress can be aborted by the user by pressing and holding the CFM and down arrow keys together (CFM first), or through RS485 by sending the appropriate command. After aborting, no hold mode end delay is waited. When the advanced cleaning is aborted, in any case a complete rinsing is done before the actual termination of the cleaning action.

The user can configure some errors to trigger a simple or advanced cleaning action (whichever is enabled). This action is performed max 2 times; if the error is not closed after two complete cleaning cycles, no further cleaning action will be performed (the second cleaning takes place only when the first cycle does not solve the problem). The device overrides the minimum pause time and starts the cleaning action immediately upon error generation.

No calibration can be performed if cleaning is in progress, and no cleaning can be triggered if the device is in calibration mode.

COMMUNICATION

For remote interaction with your controller, enter the setup mode, confirm the “Communication” menu, and select the “Connection type” from among 4 available options:

- PC
- HI 504900 GSM module
- HI 504901 GSM supervisor
- HI 504902 Modem

PC COMMUNICATION

Choose the “PC” connection type to communicate with the controller from your PC, through an RS485 network and the **HI 92500** Windows® compatible software.

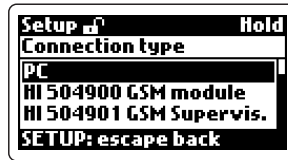

RS485 standard is a digital transmission method that allows long lines connections. Its current-loop system makes this standard suitable for data transmission in noisy environments.

The user-friendly **HI 92500** offers a variety of features such as logging selected variables or plotting the recorded data. It also has an on-line help feature to support you throughout all operations.

The readings logged into the **HI 720** internal memory can be downloaded through **HI 92500**, which makes it possible for you to use the powerful means of the most diffused spreadsheet programs.

Simply run your favorite spreadsheet program, open the file downloaded through **HI 92500**, and you will be able to elaborate the data with your software (e.g. graphics, statistical analysis).

To install **HI 92500** you need just a few minutes to follow the instructions printed on the disk’s label.

Specifications

The RS485 standard is implemented in the **HI 720** series with the following characteristics:

- Data rate: up to 19200 bps (manually selected)
- Communication: Bidirectional Half-Duplex
- Line length: up to 1.2 km typ. with 24 AWG cable
- Loads: up to 32 typ.
- Internal termination: none

Connections

The connections for the 6-pin RS485 terminal provided are as follows:

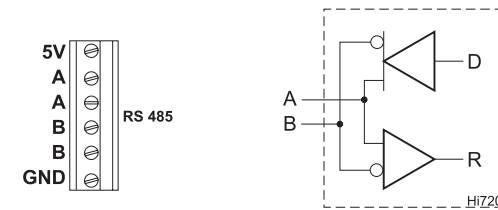

There is an internal short between the two A pins and between the two B pins. The instrument has no internal line termination. To terminate the line, an external resistor equal to the characteristic line impedance (typically 120Ω) must be added at both ends of the line.

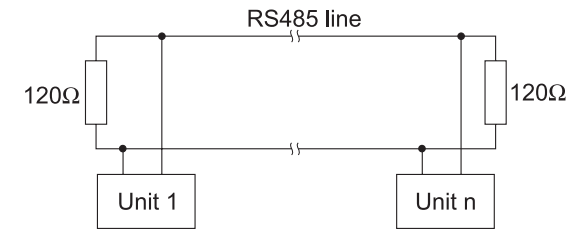

The RS485 can connect up to 31 controllers on the same physical network. All the units are slave devices and are monitored and controlled by a single master station (typically an industrial PLC or PC).

Each **HI 720** unit is identified by its Process ID number (00 to 99), which corresponds to the Process ID configured through the setup item G.11.

(If the instrument does not recognize the address within the command string, then it discards all the following bytes).

As additional feature, the controller is also provided with two pins (5V and GND) in order to apply the Fail Safe Open Line protection method. To avoid erroneous readings in Open-Line conditions, pull-up and pull-down resistors should be connected as shown.

The Fail-Safe resistors are connected only to one unit in the line, and their value depends on the application and characteristic impedance of the connection cable.

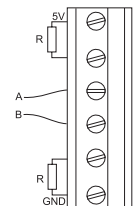

The GND pin of the interface connector and all the interface signals are optoisolated from instrument ground, probe and temperature sensor.

Before connecting the meter to the computer, consult the computer manual.

The process controller can only work as a slave component. In other words it can work as a remote terminal equipment answering to the commands only.

RS485 Protocol for HI 720

Commands are composed of four parts: address, command identifier, parameter, end of command. The end of command corresponds to the CR char (0x0d). Some commands are used when the master is requesting information from the controller, others when the master wants to set a parameter in the process memory (RAM or EEPROM).

The master software must send the command string with a maximum delay of 20 ms between each character.

If the general password has not been entered, the program on the master must not allow setting commands other than keyboard or cleaning start/stop commands. After the general password recognition through the "PWD" command, a 1-minute time-out is let before the process meter locks again, i.e. if the PC program waits for more than 1 minute between two subsequent commands, the second one is not fulfilled and the "PWD" command must be issued again.

This is the complete list of available commands:

Command	Parameter	Remarks
MDR	not available	Requests the software code for model identification (always available)
HOP	not available	Requests hardware options
STS	not available	Requests the instrument status (relays, LEDs, configuration change flag, etc.)
ECR	not available	Requests last acquired conductivity, TDS or concentration value (always available, but the retrieved value is the last measurement performed when the controller was in idle or control mode)
TMR	not available	Requests last acquired temperature value (always available, but the retrieved value is the last measurement performed when the controller was in idle or control mode)
CAR	not available	Requests last calibration data (always available)
GET	CNN	Requests setup item C.NN (e.g. "r.01" ; always available)
PWD	C ₁ C ₂ C ₃ C ₄	Sends the general password (always available)

Command	Parameter	Remarks
SET	CNNP ₁ P ₂ C ₁ C ₂ C ₃ C ₄	Sets setup item C.NN (e.g. "r.01") with parameter P ₁ P ₂ C ₁ C ₂ C ₃ C ₄ (*) (not available if the controller is in setup mode)
EVF	not available	Requests the event log file (not available if the controller is in setup mode)
EVN	not available	Requests new event log file (not available if the controller is in setup mode)
AER	not available	Requests active errors (always available)
CLS	not available	To start cleaning (for advanced cleaning; always available)
CLP	not available	To abort cleaning (always available)
HLD	not available	To enter/exit the hold mode (always available; password required)
KDS	not available	Same as DIAG key (always available)
KCD	not available	Same as CAL DATA key (always available)
KUP	not available	Same as up arrow key (always available)
KRG	not available	Same as right arrow key (always available)
KST	not available	Same as SETUP key (always available)
KCL	not available	Same as CAL key (always available)
KDW	not available	Same as down arrow key (always available)
KCF	not available	Same as CFM key (always available)

(*) C₁C₂C₃C₄ are ASCII chars corresponding to the setup item content; P₁ is an additional byte used for sign as follows:

$$P_1 = + \text{ if } > 0$$

$$P_1 = - \text{ if } < 0$$

When the sign is not used, set P₁ to "+".

P₂ is used with particular meaning for the following items:

G.01: P₂ = 0 if range is 1999 μS/cm
P₂ = 1 if range is 19.99 mS/cm
P₂ = 2 if range is 199.9 mS/cm

G.02: P₂ = 0 if range is 1000 ppm
P₂ = 1 if range is 10.00 ppt
P₂ = 2 if range is 100.0 ppt
P₂ = 3 if range is 1000 ppt

b.33, d.03: $P_2 = 0$ if range is 1999 $\mu\text{S}/\text{cm}$
 $P_2 = 1$ if range is 19.99 mS/cm
 $P_2 = 2$ if range is 199.9 mS/cm
 $P_2 = 3$ if range is 2000 mS/cm

C.11, C.12, C.13, C.21, C.22, C.23, C.30, C.31, C.34, O.12, O.13, O.15:
 if G.00 = "Conductivity" or "TDS"
 $P_2 = 0$ if range is 1999 $\mu\text{S}/\text{cm}$ or 1000 ppm
 $P_2 = 1$ if range is 19.99 mS/cm or 10.00 ppt
 $P_2 = 2$ if range is 199.9 mS/cm or 100.0 ppt
 $P_2 = 3$ if range is 2000 mS/cm or 1000 ppt
 if G.00 = "Concentration"
 $P_2 = 0$ if concentration unit = ppm
 $P_2 = 1$ if concentration unit = ppt

d.05: $P_2 = 0$ if concentration unit = ppm
 $P_2 = 1$ if concentration unit = ppt

For the following items a particular codification is used:

G.00 Conductivity = Cond
 Concentration = Conc
 TDS = *tdS

G.01 Auto range = Auto ; 1999 $\mu\text{S}/\text{cm}$ = 1999
 19.99 mS/cm = 1999 ; 199.9 mS/cm = 1999
Note: use P_2 for range specification. See above.

G.02 Auto range = Auto
 1000 ppm = 1000 ; 10.00 ppt = 1000
 100.0 ppt = 1000 ; 1000 ppt = 1000
Note: use P_2 for range specification. See above.

G.03 Auto (ppm/ppt) = Auto
 ppm = *PPM ; ppt = *PPt ; % = PErC

G.04 XXXX = XXXX ; XXX.x = XXXx
 XX.xx = XXxx ; X.xxx = Xxx

G.13 English = 0 ; Italiano = 1

G.15, C.00, C.51, C.52, C.53, C.54, C.55, C.56, C.57, I.12
 On = *On ; Off = OFF

b.01 Automatic (ATC) = *AtC
 Manual (MTC) = USEr

b.03 $^{\circ}\text{C}$ = C ; $^{\circ}\text{F}$ = F

b.10 Linear = LinE ; NaCl = nACL ; User = USEr

b.11 20 $^{\circ}\text{C}$ = 20 ; 25 $^{\circ}\text{C}$ = 25

C.10, C.20 Disabled = OFF
 On/Off high = OOHI ; On/Off low = OOLO
 PID high = PIdH ; PID low = PIdL

O.01, O.02 Disabled = OFF
 Control-setpoint 1 = SEt1
 Control-setpoint 2 = SEt2
 Simple cleaning = SCLE
 Hold mode = HOLd

O.03, O.04 Disabled = OFF
 Simple cleaning = SCLE
 Advanced cleaning = ACLE
 Hold mode = HOLd

O.05 Disabled = OFF
 Hold mode = HOLd

O.10, O.20 Recorder = rECO
 Control-setpoint 1 = *SEt
 Control-setpoint 2 = *SEt

O.11, O.21 0-20 mA = 0-20 ; 4-20 mA = 4-20

O.14, O.24 User selected value = USEr
 Previous value = HOLd

I.00 Inductive probe = Prob
 Digital transmitter = trAn

I.04 1200 bps = 1200 ; 2400 bps = 2400
 4800 bps = 4800 ; 9600 bps = 9600
 19200 bps = {200

I.11 Disabled = OFF
 1 hour = **1 ; 2 hours = **2 ; 4 hours = **4

L.15 Timer only = **ti
 External only = ***E
 Timer and external = ti E
 Timer masked by external = tiEM

E.99 Level = **LE ; Pulse = PULS

When an item is shorter than 4 digits, the C_i characters are filled with blanks.

These are some examples for setup item format:

- C.32, maximum relay ON time: value = 15, format = "+015 \diamond \diamond ", where \diamond indicates a blank space
- C.21, setpoint 2 value: value = 123.4 mS/cm, format = "+21234"
- b.01, temperature compensation: value = "AtC", format = "+0*AtC"

For all items with a fixed set of choices, blank spaces on the left of the value displayed are replaced with "*" (as many "*" characters are needed to reach the maximum string length, which is for example 3 for item C.57).

Blanks must be put on the tail for all items in order to have always a total length of 6 characters (see the setup table for item lengths).

The same parameter format used for setup item setting is also used for setup item getting (i.e. when a "GETCNN<CR>" command is received from the PC, the reply "NN<STX>P₁P₂C₁C₂C₃C₄<ETX>" is sent back).

To perform a "SETCNN..." command, the general password has to be sent in advance through the "PWD..." command. See above for the password effectiveness time-out. Some special setup items (see "Setup" section) can not be set through RS485 commands. Note that no validity check of the sent item value is performed upon reception of a "SETCNN <CR>" command. This check is done by the **HI 92500** software and must also be done by different programs.

The "SET..." and "GET..." commands when used for password items, b.50 item and all items of the "Communication" group are answered with "NN<CAN>".

As soon as the process controller realizes that a command has been received, it sends one of the following answers:

- 1) "NN", ACK (char 0x06) if the process controller recognizes the set command and performs the requested task
- 2) "NN", STX (char 0x02), DATA, ETX (char 0x03) if the received command is a request of data
- 3) "NN", NAK (char 0x15) if the process controller does not recognize the command or if the command syntax is wrong
- 4) "NN", CAN (char 0x18) if the process controller can not answer to the request (e.g. the current process model does not support the request, the given general password is wrong, etc.)

For RS485, the minimum delay between the last received and the first sent characters is 15 ms to allow the master to set itself into receive mode.

The "NN" in the front of the answer is the Process ID (00 to 99).

Here are descriptions of the answer format (for setup item request see above):

The **MDR** request produces the following answer:

"NN<STX>FP720XYZVV--ABCD<ETX>"

where VV is the firmware version, e.g. "10" for 1.0; XYZ are the three model digits, e.g. XYZ=224 for dual setpoint, PID control, dual analog output; AB is

the first HI 92500 software version compatible with the firmware, even if it may not be able to exploit all the features of the firmware, e.g. "34" for 3.4; CD is the first HI 92500 software version fully compatible with this firmware, e.g. "45" for 4.5.

The **HOP** request produces the following answer:

"NN<STX>C₁C₂C₃C₄<ETX>"

where C₁C₂ are the ASCII representation of byte B₁ described below (e.g. B₁ = 0xF3, C₁ = "F", C₂ = "3"), C₃C₄ are the ASCII representation of byte B₂ described below (e.g. B₂ = 0x1D, C₃ = "1", C₄ = "D").

The meaning of B₁ and B₂ is:

B ₂	bit 0	optional relay 2 (1: available; 0: not available)
B ₂	bit 1	Digital Transmitter input (1: available; 0: not available)
B ₂	bit 2	PID control (1: available; 0: not available)
B ₂	bit 3	free for future use (and set to 0)
B ₂	bit 4	free for future use (and set to 0)
B ₂	bit 5	free for future use (and set to 0)
B ₂	bit 6	free for future use (and set to 0)
B ₂	bit 7	free for future use (and set to 0)
B ₁	bit 0	serial port (1: available, 0: not available)
B ₁	bit 1	serial port type (0: RS485)
B ₁	bit 2	analog outputs (1: available, 0: not available)
B ₁	bit 3	second analog output (1: available, 0: not available; no meaning if bit 2 = 0)
B ₁	bit 4	optional relays 3 and 4 (1: available, 0: not available)
B ₁	bit 5	hold digital output (1: available)
B ₁	bit 6	free for future use (and set to 0)
B ₁	bit 7	relay 1,2,3,4 type (0: electromechanical)

The **ECR** request produces the following answer:

"NN<STX><ascii string for measure>S<ETX>"

where <ascii string for measure> contains the conductivity or TDS or concentration measure displayed on the LCD, followed (without any space) by the measure unit (μS, mS, ppm, ppt or %). When the measure is out of range, all digits are replaced with ">" character.

To distinguish between a TDS or concentration measure, request G.00 setup item. "S" means "status" and can be equal to:

- "A", i.e. control and alarm are ON
- "C", i.e. control is ON and alarm is OFF
- "N", i.e. control is OFF

Examples of answer to the **ECR** command are:

- $NN<STX>02.16mSC<ETX> = 2.16 \text{ mS/cm}$, control is ON & alarm is OFF
- $NN<STX>1886\mu SN<ETX> = 1886 \mu\text{S/cm}$, control is OFF
- $NN<STX>00.94pptA<ETX> = 0.94 \text{ ppt}$, control and alarm are ON
- $NN<STX>>>.>mSN<ETX> = \text{overflow (range } 199.9 \text{ mS/cm)}$, control is OFF

The answer to the **TMR** command is:

$“NN<STX><ascii \text{ string for a float}>S<ETX>”$

where “S” means “status” and can be equal to:

- “A”, i.e. control and alarm are ON
- “C”, i.e. control is ON and alarm is OFF
- “N”, i.e. control is OFF

Examples of answer to the **TMR** command are:

- $NN<STX>25.0C<ETX> = 25.0^\circ\text{C}$, control is ON & alarm is OFF
- $NN<STX>-2.8N<ETX> = -2.8^\circ\text{C}$, control is OFF

The answer to the **STS** command is:

$“NN<STX>C_1C_2C_3C_4<ETX>”$

Where C_1C_2 are the ASCII representation of byte B_1 described below (e.g. $B_1 = 0xF3$, $C_1 = “F”, C_2 = “3”$), C_3C_4 are the ASCII representation of byte B_2 described below (e.g. $B_2 = 0x1D$, $C_3 = “1”, C_4 = “D”$).

The meaning of B_1 and B_2 is:

B_2	bit 0	alarm relay (1: energized, 0: de-energized)
B_2	bit 1,2	red LED (bit 2 = 0 and bit 1 = 0: LED is OFF; bit 2 = 1 and bit 1 = 0: LED is fixed ON; bit 2 = 1 and bit 1 = 1: LED blinks)
B_2	bit 3	relay 1 (1: energized, 0: de-energized)
B_2	bit 4	relay 2 (1: energized, 0: de-energized)
B_2	bit 5	relay 3 (1: energized, 0: de-energized)
B_2	bit 6	relay 4 (1: energized, 0: de-energized)
B_2	bit 7	hold digital output (1: energized, 0: de-energized)
B_1	bit 0	control (1: ON, 0: OFF)
B_1	bit 1,2	setup mode (bit 2=0 and bit 1=0: not in setup mode; bit 2=1 and bit 1=0: setup mode, view only; bit 2=1 and bit 1=1: setup mode, unlocked)
B_1	bit 3	calibration mode with device unlocked (1: yes, 0: no)

B_1	bit 4	setup updated (set to 1 after a device power-up, device reset or a change in setup made through instrument keyboard; reset to 0 after receiving a GET command)
B_1	bit 5	calibration mode (set to 1 after a device power-up or whatever complete calibration; reset to 0 after receiving a CAR command)
B_1	bit 6	hold mode (1: ON, 0: OFF)
B_1	bit 7	error indication for concentration table (if G.00 = “Concentration”) or for user temperature compensation table (if G.00 = “Conductivity” or “TDS”) (1: there are some errors, 0: no error)

The **CAR** request produces the following answer:

If conductivity has not been calibrated: $“NN<STX>0<ETX>”$

If calibration has been performed: $“NN<STX>1\$calib.performed\$date\$time \$calibration \text{ point}\$cell_constant \text{ or } inst_factor\$<ETX>”$

The items in italic are separated by \$ character and have the following formats:

- *calib.performed* fix ASCII string (“Conductivity calibrated”)
- *date* ddmmyy (“020404” for April 2, 2004)
- *time* hhmm (“1623” for 4:23 pm)
- *calibration point* ASCII string (e.g. “with manual setting”
“on user point:2.00 uS”
“solution:0, 1413 uS”)
- *cell_constant or inst_factor* ASCII string (e.g. “Cell constant:2.051”
“Inst. factor: 1.001”)

The event log file is requested through the **EVF**<CR> command. The total length of the event log file is 100 records. Here is the answer format:

If there is no generated error or event, the answer has the format $“NN<STX>0<ETX>”$, otherwise:

$“NN<STX>events_no \\ \backslash \backslash event_code, \$desA_1 \$desB_1 \$start_date_1 \$start_time_1 \$end_date_1 \$end_time_1 \$desC_1 \$desD_1 \$ \\ \backslash \backslash event_code_2 \$desA_2 \$desB_2 \$start_date_2 \$start_time_2 \$end_date_2 \$end_time_2 \$desC_2 \$desD_2 \$ \\ \backslash \backslash \dots event_code_m \$desA_m \$desB_m \$start_date_m \$start_time_m \$end_date_m \$end_time_m \$desC_m \$desD_m \$ \\ \backslash \backslash <ETX>”$

where m is the number of events.

Each token is followed by a \$ character.

“events_no” is the number of events and its format is the ASCII format for a number (“1”, “2”.... “99”, “100”).

The meaning of "start_date_i" and "start_time_i" is:

- for errors: date and time at which the error was generated
- for setup events: date and time of a setup item change
- for calibration events: date and time of a calibration
- for cleaning events: start date and time of cleaning action

The meaning of "end_date_i" and "end_time_i" is:

- for errors: end date and time if the error is not active anymore
- for setup events: not used
- for calibration events: not used
- for cleaning events: not used

The token format is described here below:

event_code _i (errors)	"E"	
event_code _i (setup)	"S"	
event_code _i (calibration)	"C"	
event_code _i (cleaning)	"L"	
desA _i (errors)	Error code label	(e.g. "Error 21")
desA _i (setup)	Group label	(e.g. "Control")
desA _i (calibration)	Calibration type	(e.g. "Conductivity calibrated")
desA _i (cleaning)	Cleaning type	(e.g. "Simple cleaning")
desB _i (errors)	Error description	(e.g. "Temperature level")
desB _i (setup)	Item description	(e.g. "Control enable")
desB _i (calibration)	Not used	
desB _i (cleaning)	Not used	
start_date _i	ddmmyy	(e.g. "010705" for July 1, 2005)
start_time _i	hhmm	(e.g. "1735" for 5:35 pm)
end_date _i (active errors)	Not used	
end_date _i (not active err.)	ddmmyy	(e.g. "020705" for July 2, 2005)
end_time _i (active errors)	Not used	
end_time _i (not active err.)	hhmm	(e.g. "0920" for 9:20 am)
desC _i (errors)	Not used	
desC _i (setup)	Item prev. value	(e.g. "Off")
desC _i (calibration)	Calibration point	(e.g. "solution: 0, 1413 uS")
desC _i (cleaning)	Not used	
desD _i (errors)	Not used	
desD _i (setup)	Item new value	(e.g. "On")

desD _i (calibration)	USED FOR COND. CALIBRATION ONLY
	Cell constant or installation factor value
desD _i (cleaning)	Not used

Events are logged in the event log file in chronological order, i.e. record number 1 refers to the oldest event. When the event log file is full, the oldest event is replaced with the oncoming one.

The characters of the answer to the EVF command may be separated by delays, because it is necessary to guarantee the execution of measurement and control tasks while sending the long (and time consuming) answer.

A small subset of the event log file, with information about the active errors, can be downloaded through the **AER**<CR> command, always available, even during controlling.

The answer is: "NN<STX>C₁C₂C₃C₄C₅C₆<ETX>"

where C₁C₂ are the ASCII representation of byte B₁ described below (e.g. B₁ = 0xF3, C₁ = "F", C₂ = "3"), C₃C₄ are the ASCII representation of byte B₂ described below (e.g. B₂ = 0x1D, C₃ = "1", C₄ = "D"), C₅C₆ are the ASCII representation of byte B₃ described below (e.g. B₃ = 0xBE, C₅ = "B", C₆ = "E").

The meaning of B₁, B₂, B₃ is:

B ₃	bit 0	High alarm
B ₃	bit 1	Low alarm
B ₃	bit 2	Maximum relay ON time exceeded
B ₃	bit 3	Life check error
B ₃	bit 4	Conductivity input underflow
B ₃	bit 5	Conductivity input overflow
B ₃	bit 6	free for future use (and set to 0)
B ₃	bit 7	free for future use (and set to 0)
B ₂	bit 0	Calibration time-out
B ₂	bit 1	Temperature probe broken
B ₂	bit 2	free for future use (and set to 0)
B ₂	bit 3	Digital transmitter error
B ₂	bit 4	Power reset
B ₂	bit 5	EEPROM corruption
B ₂	bit 6	Watchdog reset
B ₂	bit 7	Temperature level
B ₁	bit 0	User compensation table temperature error

B ₁	bit 1	Temperature outside the user concentration table
B ₁	bit 2	Conductivity outside the user concentration table
B ₁	bit 3	Concentration outside the user concentration table
B ₁	bit 4	free for future use (and set to 0)
B ₁	bit 5	free for future use (and set to 0)
B ₁	bit 6	free for future use (and set to 0)
B ₁	bit 7	free for future use (and set to 0)

Each bit is equal to 1 if the correspondent error is ON, and equal to 0 if the correspondent error is OFF (error is always off and the bit equal to 0 if the correspondent feature is not available).

After having issued the HLD<CR> command to enter the hold mode, it must be issued again to exit from the mode. Therefore, if the device was in hold mode, issuing the HLD<CR> command the first time will have no effect.

SHORT MESSAGING SERVICE (SMS)

It is possible to connect the controller to a GSM cellular engine (**HI 504900** or **HI 504901**). This connection enables the instrument to send SMS to one (or two) cellular phone(s) and through this feature the device can be monitored at any moment. Moreover, if an error occurs on the **HI 720**, it is possible to receive an alarm SMS which immediately advises about the problem.

The SMS feature can be enabled by selecting the connection type "HI 504900 GSM module" or "HI 504901 GSM Supervisor".

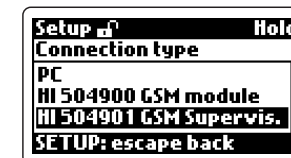
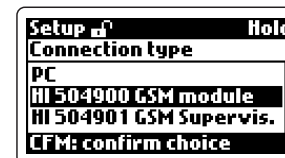

The **HI 504901** supervisor is capable of monitoring the controllers in the network (and SMS messaging is configured in **HI 504901**), while the **HI 504900** is controlled by one **HI 720**. This section explains how to set the **HI 720** for commanding an **HI 504900** module.

Before enabling this feature it is necessary to enter the PIN of the GSM engine SIM card (setup item P.11) and one or two phone numbers associated with the service (setup items P.12 and P.13).

If one or two phone numbers have already been set in items P.12 and P.13, when the service is activated these numbers will be saved on the module SIM card (the numbers are saved on the first two locations of the phone book area; if some numbers were previously stored, they will be overwritten).

If no phone number has been set in setup items P.12 and P.13, the instrument tries to read the SIM card, looking for previously saved numbers associated with the names "HI720_#1" and "HI720_#2". If any is found, then the phone number(s) will be loaded by the instrument and the SMS service activated. Otherwise, if the instrument does not find any correct number, the SMS service will not be activated.

If the PIN code set in P.11 is wrong, then the "Wrong PIN code!" message will appear and it will not be possible to switch from "PC" to any GSM connection. If the first attempt to initialize the GSM cellular engine fails because of wrong PIN, no other attempt will be allowed until the setup item P.11 is modified (to prevent the sending of wrong PIN three times. In fact, in this case the SIM card needs to be unlocked, and the user must extract the SIM card to enter manually the PUK code using his own cellular phone).

The communication baud rate is set through the item P.01 and it will be the same for any connection type.

To have an error associated with the SMS service, the proper configuration has to be selected in the "Error Menu".

When an error configured for the SMS service is switched on, the following message will be sent to the programmed number(s):

"Rem_msg: xxx; The following error occurred on HI720: XXXXX"

where xxx is a 3-digit number indicating the remaining messages and XXXXX represents a text string corresponding to the activated error.

This is the list of all possible error strings:

- "High alarm"
- "Low alarm"
- "Max relay ON time error"
- "Life check error"
- "Conductivity input overflow"
- "Calibration timeout"
- "Broken temperature probe"
- "Digital transmitter error"
- "Temperature compensation error"
- "Temperature outside the user concentration table"
- "Conductivity outside the user concentration table"
- "Concentration outside the user concentration table"
- "EEPROM corruption"
- "Temperature level error"

Since an SMS sometimes can be received with a considerable delay, the instrument also calls the programmed phone number(s) to immediately advise the user that something is happening on the **HI 720** and an SMS is on the way.

When an alarm SMS is sent, then the instrument waits for a confirmation by the user of message reception. The receiver should confirm by simply calling the phone number of the GSM engine SIM card.

You can also configure the instrument for repeated sending of message if a confirmation is not received immediately (setup items P.15 and P.16). This feature will prevent from losing any warning message due, for example, to the overcharge of the telephone network. The item P.15 indicates the number of repeated messages, while P.16 sets the delay between two subsequent messages.

A phone call from one of the programmed numbers to the instrument, is under-

stood as an information request. The instrument will hang up the call and send an SMS about its current status (number of remaining messages, currently measured values and active errors). The message will be, for example:

"Rem_msg: 150; 1832 uS/cm; 025.8C; Err: xxxxx, xxxxx"

Each message is made of a maximum of 160 characters. For this reason, a coded notation is used to indicate the active errors, as listed below:

- High alarm: "HI Alarm"
- Low alarm: "LO Alarm"
- Max relay ON time error: "Rel on"
- Life check error: "Life chk"
- Conductivity input overflow: "Con over"
- Calibration timeout error: "Cal tout"
- Broken temperature probe: "Brk temp"
- Digital transmitter error: "Tx err"
- Temperature compensation error: "Tem com"
- Temperature outside the user concentration table: "Temp out"
- Conductivity outside the user concentration table: "Cond out"
- Concentration outside the user concentration table: "Conc out"
- EEPROM corruption error: "EEPr cor"
- Temperature level error: "Temp lvl"

If no error is active, the "No error" string will be sent.

If the instrument receives the information request while in hold mode, the "Hold;" string is added before the conductivity (or concentration) indication. If the instrument is performing a cleaning action, the "Cleaning;" string is added.

All information about the SIM card, such as charge and expiration date, are managed by the network operator. To prevent the discharge of the SIM card, manual configuration is necessary for the maximum number of SMS that can be sent (item P.14), according to the SIM card credit.

When the maximum number is approaching zero, the message "Rem_msg: xxx; Maximum number of SMS reached. Please check the HI720 SIM card charge level" will be sent by the instrument to the programmed number(s). This situation is handled as an error occurrence and confirmation of SMS reception is expected.

In this case the SIM card should be extracted from the cellular engine and the remaining credit checked by calling the network operator with a normal cellular phone. When a confirmation is given to the message, the "GSM/Modem module error" is switched on and no more messages will be sent.

To close the "GSM/Modem module error", modify the setup item P.14 (the value of this item - remaining number of available messages - is automatically decremented each time an SMS is sent).

When the SIM card is recharged, its expiration date has to be manually updated (setup items P.17 to P.19).

The instrument compares the expiration date with the current date (from RTC), and two weeks before the expiration date the following message is sent to the programmed phone number(s): "Rem_msg: xxx; The HI720 SIM card will expire on: DD-MM-YYYY. Please recharge or substitute it". The same message will also be sent one week before and the day before the expiration date. This particular warning does not need confirmation.

If the expiration date is reached without any update of items P.17 to P.19, then the "GSM/Modem module error" will be switched on and no more messages will be sent by the instrument until the error is closed, by updating the expiration date.

If the SIM card has unlimited credit, the setup item P.14 has to be set to "222", that means unlimited number of messages. The number of remaining messages will never be decremented and no check will be performed on the SIM expiration date. Moreover, at the beginning of the SMS the remaining messages warning ("Rem_msg: xxx") will be not present.

It is also possible to ask information (about current readings and active errors) to the **HI 720** from a cellular phone different from the one(s) selected through the items P.12 and P.13. This is accomplished by sending to the instrument the SMS "+Pxx", where "xx" indicates the ID of the **HI 720** (setup item G.11).

The instrument will recognize the command and reply with the requested information.

If a communication problem occurs during the normal functioning of the instrument, the "GSM/Modem module error" will be switched on and no SMS will be submitted until this error will be deactivated (when this error occurs, the instrument will try repeatedly to initialize the cellular engine and the error will be deactivated only after a successful initialization, or if the SMS service is disabled by setting the item P.00 to "PC").

MODEM CONNECTION

A modem connection can be established between **HI 720** and a remote computer over telephone line. Two different types of remote connection are possible:

- Over the GSM network, connecting the **HI 504900** cellular module to the RS485 port of **HI 720**.

To enable the modem connection with **HI 504900**, first configure the cellular phone (refer to "Short Messaging Service" section for more details) and in particular choose the "HI 504900 GSM module" connection type. Then set item P.02 ("Call answer enable") to "On".

Note A SIM card able to receive data calls must be used.

- Over a standard analog telephone line, connecting the **HI 504902** modem module to the **HI 720** RS485 port.

To enable the modem connection with **HI 504902**, choose the "HI 504902 Modem" connection type, then set P.02 to "On" and finally set P.03 with the dialling code of the country where the instrument is installed (for example "049" for Germany or "001" for United States).

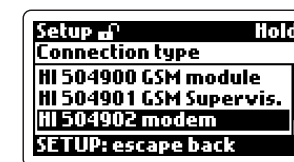

Note The **HI 504902** modem module must be connected to the **HI 720** RS485 port (not necessary to the telephone line), and switched on while the previous configuration is carried out.

Note If the country code is shorter than 3 characters, fill the code with zeros in front (for example the country code "49" must be entered as "049" or the country code "1" must be entered as "001").

Note The modem present in the **HI 504902** module is Telecom certified for working in all the following countries: Argentina, Australia, Austria, Belgium, Brazil, Canada, Chile, China, Cyprus, Czech Republic, Denmark, Finland, France, Germany, Greece, Hong Kong, Hungary, Iceland, India, Indonesia, Ireland, Israel, Italy, Japan, Korea, Liechtenstein, Luxembourg, Malaysia, Mexico, Netherlands, New Zealand, Norway, Philippines, Poland, Portugal, Russia, Singapore, Slovak Republic, South Africa, Spain, Sweden, Switzerland, Taiwan, Turkey, United Kingdom, United States.

If your country is not present in the list, please contact your Dealer.

The modem connection (both with **HI 504900** and **HI 504902**) allows the user to ask the controller from a remote position about its current status & readings, and change some parameters, while for receiving alarm indications it is necessary to install the **HI 504900** cellular module.

Many devices can be monitored through a remote modem, simply connecting all the devices and the modem (or cellular module) to the same RS485 network.

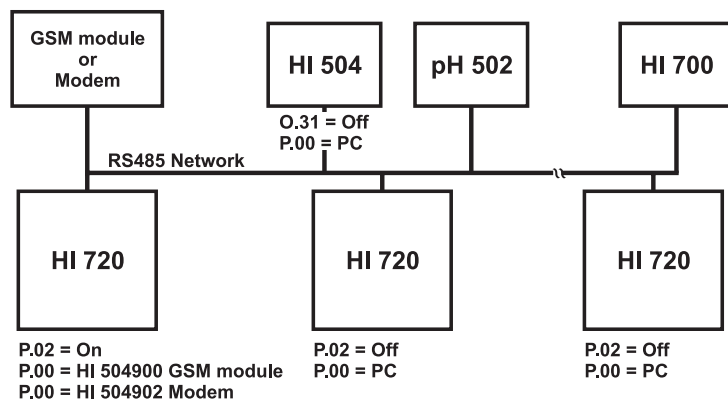

Only one device can be configured through the item P.02 to answer to modem calls, and this will control the modem or cellular module.

To avoid conflicts, never do any of the following actions:

- put more than one modem or cellular module in the same RS485 network
- set P.02 to "On" in more than one device in the same RS485 network
- set P.00 to "HI 504900 GSM module" in more than one device in the same RS485 network (with HI 504900, SMSs can not be sent from more than one HI 720)
- set P.02 to "On" in one device and P.00 to "HI 504900 GSM module" in another one within the same RS485 network
- put a PC monitor within the RS485 network

Provided the above, any Hanna instrument with an RS485 port can be attached to the network and monitored remotely.

When making a call, after the data connection is established, the "NNPWD..." command (where "NN" is the address of the device controlling the modem, i.e. the one with P.02 set to "On") must be issued by the remote computer within 15 seconds.

When the data connection is up, the RS485 protocol for a remote connection is all the same as for a local network. An automatic disconnection takes place if no character is received in the RS485 network in 3-4 minutes.

When a modem connection is up, the cellular module does not send any SMS.

If an error configured for SMS sending occurs, the relating alarm SMS will be submitted by the HI 720 after modem disconnection.

ERRORS - FAULT CONDITIONS

The below fault conditions may be detected by the software:

- EEPROM data error
- serial communication internal bus failure
- software dead loop

EEPROM data error can be detected through EEPROM test procedure at start-up or when explicitly requested using setup menu, or during normal operational mode if a checksum control fails.

When an EEPROM error is detected, a fault alarm is generated according to the user configuration for the EEPROM corruption error (see "Alarm - Error configuration" section), and the user will be asked to confirm or ignore a request of EEPROM reset.

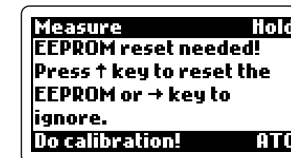

If the request is ignored, the controller restarts operation, but alarm actions are performed as configured by the user (see "Alarm - Error configuration" section). Note that the device will be in Hold mode in any case.

If the reset action is confirmed, all the data stored in the EEPROM are erased and the default values loaded.

After that, all calibrations must be performed in order to obtain correct measurements.

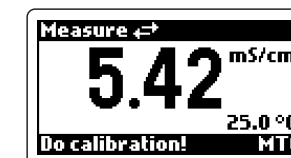

The user will be informed that calibration is needed through a "Do calibration!" message and a calibration timeout error.

Any EEPROM reset is aborted without performing any action if the user does not answer within 60 seconds.

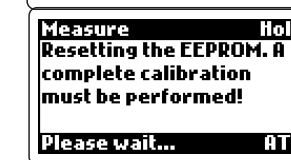

When internal transmission is not acknowledged or a bus fault occurs for more than a certain number of unsuccessful transmission attempts (due for example to a damage occurred to one of the ICs connected to the internal bus), an internal bus error is detected and the controller displays the message "Serial bus error".

If the error is due to impossible communication with the EEPROM or the RTC, all the controller tasks are stopped, the alarm relay is de-energized, the red LED blinks and the "Serial bus error" message will remain fixed on the display (repair can not be postponed).

A software watchdog is provided in order to detect dead loop conditions or other causes that make the software stuck. If it happens, a software reset is generated after a time-out of 1 second.

At start-up the instrument checks if an RTC reset occurred since last software initialization; if this is the case, the RTC is initialized with the default date and time (01/01/2000 - 00:00). An EEPROM reset does not affect the RTC settings.

ALARM - ERROR CONFIGURATION

This section is dedicated to all the possible error causes for alarm generation, and to the actions performed according to the alarm configuration (setup menu "Error configuration").

Each alarm cause can be referred to an error to which an error code is assigned and which is logged in a dedicated memory space (see "Event logging" section for more details).

Five configuring actions are foreseen upon generation of an alarm:

1. Alarm relay de-energized
2. Auto-cleaning (control actions are stopped during auto-cleaning mode)
3. 3.6 or 22 mA fault current for the 4-20 mA output; 22 mA fault current for the 0-20 mA output
4. Hold mode (entered in any case for EEPROM corruption or serial bus error)
5. Alarm SMS submission to the selected phone numbers

Note The red LED flashes in any case upon an alarm generation, i.e. it can not be disabled by changing the error configuration.

Errors, error codes & default error handling configuration are listed in this table:

ERROR	Error Code	Alarm Relay	22 mA Fault Curr.	3.6 mA Fault Current	Hold Mode	Auto-clean.	SMS Send
Low alarm	01	ON	OFF	OFF	---	OFF	OFF
Max relay ON time	02	ON	ON	OFF	---	OFF	OFF
Life check error (*)	03	ON	ON	OFF	ON	OFF	OFF
Cond. input overflow (*)	10	ON	ON	OFF	OFF	OFF	OFF
Calibration timeout	12	OFF	OFF	OFF	---	---	OFF
Broken temp. probe (*)	20	ON	ON	OFF	OFF	---	OFF
Temperature level	21	ON	ON	OFF	---	---	OFF
Dig. Transmitter error	40	ON	ON	OFF	ON	---	OFF
GSM/Modem module err.	50	ON	ON	OFF	---	---	---
Temp. compensation error	60	ON	ON	OFF	---	---	OFF
Temp. out of conc. table	61	ON	ON	OFF	---	---	OFF
Cond. out of conc. table	62	ON	ON	OFF	---	OFF	OFF
Conc. out of conc. table	63	ON	ON	OFF	---	---	OFF
Power reset	90	OFF	OFF	OFF	---	---	OFF
EEPROM corruption	91	ON	ON	OFF	---	---	OFF
Watchdog error	92	OFF	ON	OFF	---	---	OFF
Level or pulse signal	99	Level (default value) or Pulse					

(*): When the digital transmitter is used, these errors are generated in the digital transmitter, but they are handled as if they were generated in the controller.

- The 3.6 mA fault current is always off unless the 4-20 mA output has been configured; the 22 mA fault current is always off unless the 0-20 mA or 4-20 mA output has been configured.

The 3.6 mA and the 22 mA fault current cannot be both set to ON. If two errors are active when output is configured as 4-20 mA (#1 or #2), and one of them is configured for the 22 mA fault current, while the other one is configured for the 3.6 mA fault current, the 22 mA current is let out to the analog output.

The fault current is automatically disabled when the analog output is used for controlling (item O.10 equal to "Control-setpoint 1"), no matter whether the fault current itself has been configured "On" or "OFF".

- In case of a "Temperature probe broken" error, the fault current, if configured, is let out to both analog outputs (unless O.20 is equal to "Control-setpoint 2"). In all the other cases only the first analog output can let out the fault current.
- The "GSM/Modem module error" is never activated if P.00 is not set to "HI504900 GSM module" or "HI504901 GSM supervisor". The error will be active if the instrument is not able to communicate with the GSM/modem engine (for example the serial cable is broken or the engine is not powered), if the number of available SMS is finished (setup item P.14) or if the SIM expiration date is overrun.
- The "Power reset" and the "Watchdog reset" errors are active only for the short time of the start-up session (selftests, meter name and version displaying). That start-up session ends when the first measurement is acquired and displayed.
- When the Hold mode is enabled for the "Life check error", this error can be closed automatically if the measurement vary enough.

Note The alarm relay (when configured to be activated) is de-energized (fail-safe ON) continuously or with a pulse of about 5 seconds. This parameter can be configured through setup item E.99 (Level or Pulse). If the "Pulse" option is selected, a new pulse will be let out upon every new error, no matter whether the red LED is already blinking (i.e. some error is active) or not. When the pulse finishes, the relay is energized but the error remains still active (red LED blinking) until the error is closed.

Note The "Digital Transmitter error" is generated by one of the following causes:

1. Digital transmitter is off
2. Connection problems between controller & transmitter

3. EEPROM data corruption in the transmitter
4. Digital transmitter is not calibrated
5. Other failures in the transmitter excluding: life check error, conductivity input overflow, or temperature probe broken error

These errors are handled separately and exactly in the same way as if they were generated in the controller.

To understand which cause generated the “Digital Transmitter error”, the digital transmitter must be examined.

SELFTEST PROCEDURES

The selftest procedures can be performed by entering the TEST menu in the setup mode and selecting the desired test.

Note If no action is performed for about 5 minutes, the mode is automatically exited and the instruments returns to the previous operation.

DISPLAY TEST

To start the procedure confirm the “Display test” option. All display dots will be checked and then the “Display test” indication will be shown again.

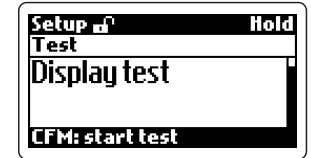

The display test is also useful to view the model name and firmware version.

Use the up and down arrow keys to skip to another test procedure.

KEYBOARD TEST

Confirm the “Keyboard test” option and a keyboard diagram will appear on the display. Press any key to test, and the corresponding indicator will be highlighted (the below example refers to the test of the SETUP key).

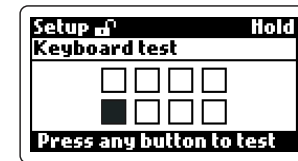
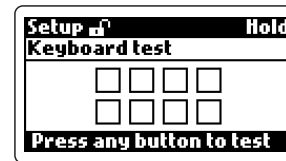

Note A maximum of two keys may be pressed simultaneously to be properly recognized.

To exit the keyboard test procedure press DIAG, CAL and SETUP simultaneously.

EEPROM TEST

The EEPROM selftest procedure involves verifying the stored EEPROM checksum, and it is activated by simply confirming the corresponding option.

While the EEPROM check is in progress, the “Please wait...” message is displayed.

If the checksum is correct, the “EEPROM test is OK!” message will appear for a few second, and the instrument will escape back to the test menu.

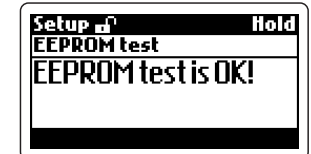
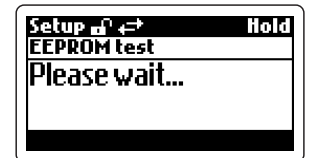

If the checksum fails, a fault alarm is generated according to the user configuration for the EEPROM corruption error (see “Alarm - Error configuration” section), and the user will be asked to confirm or ignore a request of EEPROM reset.

If the request is ignored, the controller restarts operation, but alarm actions are performed as configured by the user (see “Alarm - Error configuration” section). Note that the device will be in Hold mode in any case.

If the reset action is confirmed, all the data stored in the EEPROM are erased and the default values loaded. After that, the device must be completely recalibrated.

RELAYS AND LEDs TEST

Confirm the “Relays and LEDs test” option and the instrument will ask for pressing a button to test a relay or LED.

These are the keys used to toggle relays and LEDs ON and OFF:

- the DIAG key toggles the alarm relay and the green LED
- the CAL DATA key toggles the red LED
- the up arrow key toggles relay 1 and corresponding LED
- the right arrow key toggles relay 2 and corresponding LED
- the SETUP key toggles relay 3 and corresponding LED
- the CAL key toggles relay 4 and corresponding LED
- the down arrow key toggles the hold digital output

When a relay/LED is activated, all the others are disactivated. LEDs are verified simply by looking at them, while relays can be verified through a multimeter set for continuity test.

To exit the test press the CFM key and the previous configuration of the relays is reestablished.

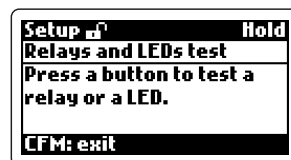

ANALOG OUTPUT TEST

To enter the analog output test procedure confirm the corresponding option and a start output value is displayed. This value is let out to the analog output and coincides with the minimum value of the selected analog output type (item 0.11 for analog output 1 and 0.21 for analog output 2).

A new output value can be edited manually. Use the up & down arrow keys to change each digit, and the right arrow to move to the next digit.



Once a value is entered, the corresponding current is immediately erogated by the selected output and no confirmation is required.

The minimum and maximum values let out are 3.6 and 22 mA for the 4-20 mA output, or 0 and 22 mA for the 0-20 mA output. This depends on the possibility of the fault currents to be let out (see “Alarm - error configuration” section).

To verify the erogated current use a multimeter connected to the corresponding output.

HOLD DIGITAL INPUT TEST

This test is made to verify if the instrument recognizes the digital input signal at the hold input. To enter the test procedure confirm the “Hold digital input test” option.

Once the test is confirmed, the display will indicate the status (“Off” or “On”) of the digital input corresponding to the hold command.

Toggle the digital input between high and low levels, and verify the corresponding status on the display.

To exit the test press the CFM key.

ADVANCED CLEANING DIGITAL INPUT TEST

To enter the test procedure confirm the “Advanced cleaning digital input test” option.

Once the test is confirmed, the display will indicate the status (“Off” or “On”) of the digital input corresponding to the advanced cleaning.

Note that if relays #3 and #4 have been configured for the advanced cleaning, and the cleaning trigger (L.15) is set to “External only” or “timer and external”, a cleaning action will be started when the digital input is on.

To exit the test press the CFM key.

ACCESSORIES

CONDUCTIVITY CALIBRATION SOLUTIONS

HI 7030L	12880 $\mu\text{S}/\text{cm}$, 500 mL bottle
HI 8030L	12880 $\mu\text{S}/\text{cm}$, 500 mL FDA bottle
HI 7031L	1413 $\mu\text{S}/\text{cm}$, 500 mL bottle
HI 8031L	1413 $\mu\text{S}/\text{cm}$, 500 mL FDA bottle
HI 7034L	80000 $\mu\text{S}/\text{cm}$, 500 mL bottle
HI 8034L	80000 $\mu\text{S}/\text{cm}$, 500 mL FDA bottle
HI 7035L	111800 $\mu\text{S}/\text{cm}$, 500 mL bottle
HI 8035L	111800 $\mu\text{S}/\text{cm}$, 500 mL FDA bottle
HI 7039L	5000 $\mu\text{S}/\text{cm}$, 500 mL bottle
HI 8039L	5000 $\mu\text{S}/\text{cm}$, 500 mL bottle

PROBE CLEANING SOLUTIONS

HI 7061M	General cleaning solution, 230 mL bottle
HI 7061L	General cleaning solution, 500 mL bottle
HI 8061M	General cleaning solution, 230 mL FDA bottle
HI 8061L	General cleaning solution, 500 mL FDA bottle

OTHER ACCESSORIES

HI 504900	Hanna GSM module
HI 504901	Hanna GSM supervisor
HI 504902	Hanna RS485 modem
BL Pumps	Dosing pumps with flow rate from 1.5 to 20 LPH
HI 7610	Stainless steel Pt100 probe with 5 m (16.5') cable
HI 7611	Glass Pt100 probe with 5 m (16.5') cable
HI 7620	Stainless steel Pt1000 probe with 5 m (16.5') cable
HI 7621	Glass Pt1000 probe with 5 m (16.5') cable
HI 92500	Windows® compatible software
HI 931002	4-20 mA Simulator
HI 98501	ChecktempC temperature tester (range -50 to 150°C)
HI 98502	ChecktempF temperature tester (range -58 to 302°F)

INDUCTIVE CONDUCTIVITY PROBES

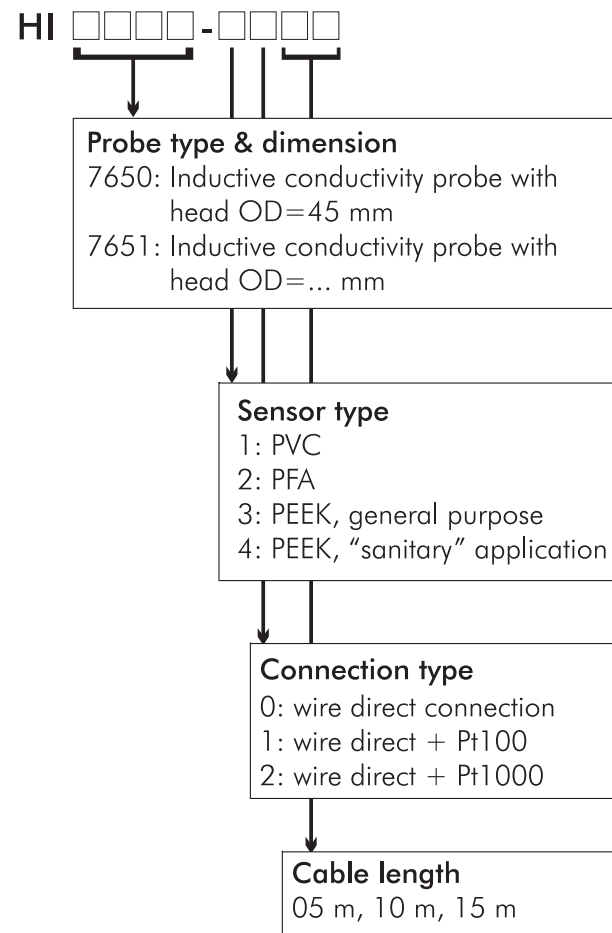

Currently available models

Inductive conductivity probe with 45 mm head OD, PVC sensor, wire direct connection, and 5, 10 or 15 m cable:

HI 7650-1005 • HI 7650-1010 • HI 7650-1015

Inductive conductivity probe with 45 mm head OD, PVC sensor, wire direct connection & Pt100 sensor, and 5, 10 or 15 m cable:

HI 7650-1105 • HI 7650-1110 • HI 7650-1115

Recommendations for Users

Before using these products, make sure that they are entirely suitable for the environment in which they are used. Operation of these instruments in residential areas could cause unacceptable interferences to radio and TV equipment. To maintain the EMC performance of equipment, the recommended cables noted in the user's manual must be used. Any variation introduced by the user to the supplied equipment may degrade the instruments' EMC performance. To avoid electrical shock, do not use these instruments when voltage at the measurement surface exceed 24 Vac or 60Vdc. To avoid damage or burns, do not perform any measurement in microwave ovens.

Unplug the instruments from power supply before the replacement of the fuse. External cables to be connected to the rear panel should be terminated with cable lugs.

SALES AND TECHNICAL SERVICE CONTACTS

Australia:

Tel. (03) 9769.0666 • Fax (03) 9769.0699

China:

Tel. (10) 88570068 • Fax (10) 88570060

Egypt:

Tel. & Fax (02) 2758.683

Germany:

Tel. (07851) 9129-0 • Fax (07851) 9129-99

Greece:

Tel. (210) 823.5192 • Fax (210) 884.0210

Indonesia:

Tel. (21) 4584.2941 • Fax (21) 4584.2942

Japan:

Tel. (03) 3258.9565 • Fax (03) 3258.9567

Korea:

Tel. (02) 2278.5147 • Fax (02) 2264.1729

Malaysia:

Tel. (603) 5638.9940 • Fax (603) 5638.9829

Singapore:

Tel. 6296.7118 • Fax 6291.6906

South Africa:

Tel. (011) 615.6076 • Fax (011) 615.8582

Taiwan:

Tel. 886.2.2739.3014 • Fax 886.2.2739.2983

Thailand:

Tel. 66-2619-0708 • Fax 66-2619-0061

United Kingdom:

Tel. (01525) 850.855 • Fax (01525) 853.668

USA:

Tel. (401) 765.7500 • Fax (401) 765.7575

*For e-mail contacts and complete list of Sales and Technical offices, please see **www.hannainst.com***