

# CASTON III

## CASTON III Crane Scale

### FEATURES

- Battery Operated w / Low Battery Indication
- Rechargeable Battery Pack
- Spare Battery Pack and Charger Included as Standard
- Easy to Read 1.5" LED Display
- Bluetooth Control Included as Standard
- On,Off, Zero, Tare and Hold(Manual or Automatic) Functions
- Auto Span Adjustment
- Auto Zero Tracking

### SPECIFICATIONS

Model	5THD	10THD	15THD	20THD	30THD	50THD
Capacity(kg)	5,000	10,000	15,000	20,000	30,000	5,000
Readability (kg)	2	5	10	10	10	20
Maximum Tare	Full Tare					
Display Type	LED					
Operating Power	DC 6V					
Power Source	AC 120V, 50 / 60Hz					
Display Designators	Zero, Tare, Hold, Batt.					
Power Consumption	1.2W					
Operating Temperature	- 10°C ~ +40°C					

### DIMENSIONS

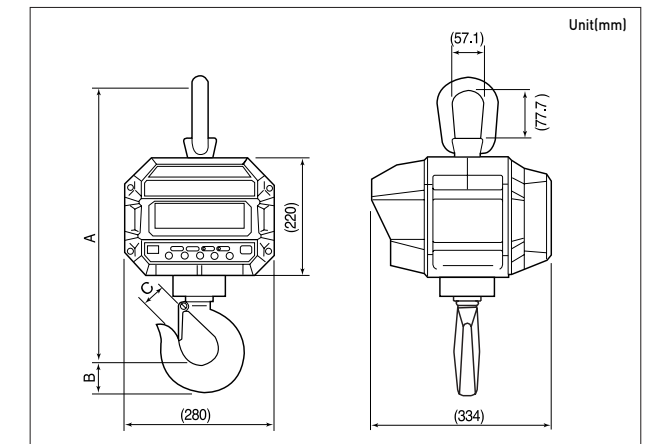

Model	A	B	C	Product Weight
5THD	(512)	(44.5)	(42.9)	31 kg

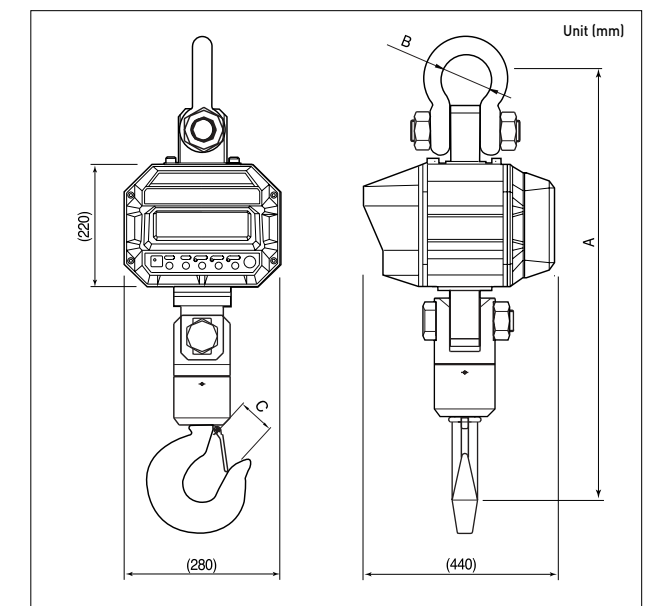

Model	A	B	C	Product Weight
10 THD	(845)	(83)	(57.2)	44 kg
15 THD	(886)	(99)	(63.5)	53 kg
20 THD	(990)	(126)	(86)	76 kg
30 THD	(1,200)	(138)	(108)	220 kg
50 THD	(1520)	(180)	(146)	410 kg

## Crane Scale

- Battery Operation
- Easy to read 1.5" LED Display
- Bluetooth Remote Control
- Environmentally Sealed (IP 65)



CAS BLDG., # 440-1, SUNGNAE DONG,  
GANGDONG GU, SEOUL, KOREA  
TEL\_ 82 2 2225 3500  
FAX\_ 82 2 475 4668  
<http://www.globalcas.com>

Specifications are subject to change for improvement without prior notice.

