

BROOKFIELD KF40
Falling Ball Viscometer
Operating Instructions
Manual No. **M19-354**



INSTRUMENTATION & SPECIALTY CONTROLS DIVISION

11 Commerce Boulevard, Middleboro, MA 02302 USA
Tel: 508-946-6200 or 800-628-8139 (USA excluding MA)
Fax: 508-946-6262 Internet <http://www.brookfieldengineering.com>

Table of Contents

I. INTRODUCTION	5
I.1 Components.....	5
I.2 Specifications.....	6
I.3 Details on Viscosity Measurement Range	7
I.4 Description of the Equipment	7
I.5 Safety Symbols and Precautions.....	10
I.6 Cleaning.....	10
II. GETTING STARTED	11
II.1 Choice of Balls.....	11
II.2 Filling the Sample Tube.....	11
II.3 Temperature Control of the Sample	12
II.4 Measuring the Falling Time.....	12
III. CALCULATIONS	14
III.1 Dynamic Viscosity	14
III.2 Kinematic Viscosity	15
IV. DETERMINATION OF THE NON-NEWTONIAN BEHAVIOR.....	16
IV.1 Thixotrophy/Rheopexy.....	16
IV.2 Structural Viscosity (Pseudoplasticity and Dilatancy).....	16
Appendix A - Maintenance	17
Appendix B - Calibration of the Ball Constants.....	18
Appendix C - Online Help and Additional Resources.....	19
Appendix D - Warranty Repair and Service.....	20

I. INTRODUCTION

Falling Ball Viscometer, Model KF40, complies with the German industry standard DIN 53015. The measuring principle, according to Höppler, is to determine the falling time of a ball in a cylindrical glass tube filled with liquid. The working angle of the falling tube in the KF40 are variable at 80°, 70°, 60° and 50° relative to horizontal. The water jacket, surrounding the falling tube, when connected to a Brookfield circulating temperature bath provides for precise temperature control of the sample.

The user calculates the dynamic viscosity of the sample by determining the falling time of the ball between the upper and lower ring marks displayed on the falling tube. Using data on the ball constants, the density difference between the liquid sample and the ball, and the working angle constant, a mathematical equation is used to convert the time measurement to a viscosity value in centipoise.

Note: The ball constants (forwards and backwards) and ball densities are listed on the test certificate accompanying the instrument. You must provide the density value for the liquid that you are testing.

The six (6) balls with different diameters and densities enable the KF40 to measure a wide range of viscosities. The ability to adjust the angle of inclination extends the measuring range for low viscosity liquids.

For non-Newtonian liquids, by subjecting the same sample to repetitive measurements with the KF40 at different angles, pseudoplastic or dilatant behavior may be determined as explained in Section IV. Time dependent behavior (thixotropy and rheopexy) may also be noted.

The ease of operation and precise temperature control, using a Brookfield circulating temperature bath, allows for very reproducible measuring results.

I.1 Components

Component	Part No.	Quantity
KF40 Falling Ball Viscometer	KF40	1
Set of (6) balls with gauge (FB68) in a carrying case (FB26) Supplied w/certificate stating diameter and mass of each ball	FB30C	1
-Ball 1 (glass)	FB1	-
-Ball 2 (glass)	FB2	-
-Ball 3 (nickel and iron)	FB3	-
-Ball 4 (nickel and iron)	FB4	-
-Ball 5 (steel)	FB5	-
-Ball 6 (steel)	FB6	-
Ball Tweezers	FB51	1
Wire Cleaning Brush for Sample Tube	FB53	1
Brush to clean loose debris from Falling Balls	FB52	1

Leather cloth for polishing Falling Balls	FB70	1
Sealant ring (perbunane) A 16x20	FB31	4
Sealant ring (silicone) 10x14x2	FB32	1
Thermometer, 0°C to +100°C	TM1	1
Operator Manual	M11-353	1
Instrument Case	FB200	1
Latex rubber tubing, 5/16 I.D. x 1/16 wall	FB69	1
Certificate of Calibration	—	1

I.2 Specifications

Viscosity Range:	0.5 - 7×10^4 mPa•s (cP)
Falling Time-Lower Limit:	60 s for Ball No.1 30 s for Ball Nos. 2,3,4,5 and 6
Falling Time-Upper limit:	300 s <i>Materials with viscosity $> 7 \times 10^4$ mPa•s require running times of over 300 s.</i>
Measuring Distance:	100 mm (50 mm between adjacent ring marks) in both directions
Fall Tube Inner Diameter:	15.94 mm +/- 0.01 mm
Set of Balls:	6 balls
Working Angle:	KF40: 80°, 70°, 60°, 50°
Temperature Range:	-5°C - +150°C
Sample Volume:	40 mL
Viscometer Accuracy:	±0.6% if the reading when used with balls 2 and 3.
Dimensions:	180 mm x 220 mm x 330 mm
Weight:	6.4 lbs, 2.9 kg (empty glass tube and empty waterbath jacket)

I.3 Details on Viscosity Measurement Range and Accuracy

Per DIN 53015, the Falling Ball method is suitable for measuring dynamic viscosities ranging from 0.6 mPa•s to 250,000 mPa•s at temperatures from -5°C to 150°C. Use is made of six balls having different diameters, each ball covering part of the range. All guideline values and referenced parameters in the following table are per DIN 53015.

Ball No.	Viscosity measurement range (guideline values) (mPa•s)	Material	Density (guideline value) (g/cm ³)	Ball diameter (mm)	Deviation from circularity (mm)	Calibration constant (guideline value) (mPa•s•cm ³ /g•s)
1	0.5 to 10	Borosilicate glass	2.4	15.81 ± .01	± 0.0005	0.007
2	9 to 140	Borosilicate glass	2.4	15.6 ± 0.05	± 0.0005	0.09
3	40 to 700	Ni/iron	8.1	15.6 ± 0.05	± 0.001	0.09
4	150 to 5,000	Ni/iron	8.1	15.2 ± 0.1	± 0.001	0.7
5	1,500 to 50,000	Ni/iron	8.1	14.0 ± 0.5	± 0.001	7
6	Above 7,500	Ni/iron	8.1	11.0 ± 1	± 0.002	35

These are the accuracy values reported in the DIN53015 standard.

AMETEK Brookfield has determined the accuracy of the viscometer using balls 2 and 3 according to the method specified in the DIN53015 standard.

To determine the accuracy of the viscometer for balls 1, 4, 5 and 6, please refer to the method specified in the DIN 53015 standard.

I.4 Description of the Equipment

Refer to Figures 1 and 2. Specific items identified on the Falling Ball Viscometer are identified by parentheses () in the following steps:

1. The Falling Ball Viscometer must be level. The level is adjusted using the three Leveling Feet (4) on the base. Adjust so that the bubble level on top of the Falling Ball Viscometer is centered within the circle. Check level periodically during use.
2. The working angles of the KF40 are 80°, 70°, 60° and 50° relative to horizontal. The DIN 53015 working position of 80° is the preferred position. The different working angles are secured by the adjustment screw (5). To select a working angle, the adjustment screw (5) should be loosened by turning it counter-clockwise approximately one rotation. After the working angle is selected, the adjustment screw should then be tightened again.
3. The two running directions of the balls can be chosen by swiveling the viscometer, which is kept in place by the Stop to hold the viscometer in position (22).
4. The glass tube (6) is surrounded by a waterbath jacket (9) which is fixed between the upper plate (7) and lower plate (8). The upper locking plug (16) with lid (20), the lower locking

plug (17) and accompanying seals (19), and the caps (18) are designed to perform the following functions within the sample tube:

- a. keep the liquid sample tightly sealed.
 - b. eliminate the formation of air bubbles.
 - c. avoid a build up of pressure
5. Mounted on the lower and upper plates are inlet/outlet ports (10a and 10b) for connection to the water bath.

NOTE: Any alteration, modification or replacement of the sample tube, water jacket, falling tube screw fittings, tension rods or balls renders the ball constants invalid and requires the re-calibration of the viscometer. See Appendix B.

6. The thermometer screw (11) and thermometer seal (13) with inserted thermometer is screwed into M10x1 Thermometer attachment thread (12) in the upper plate. The thermometer screw should be tightened securely to prevent fluid leakage.

NOTE: Caution when handling the glass thermometer!

7. The primary function of the ball gauge is to distinguish the two glass balls (Ball No. 1 and Ball No. 2) from each other. Ball No. 1 will not pass through the ball gauge, whereas Ball No. 2 will pass through. The ball gauge may also be used to help identify Ball No. 2 through 4.

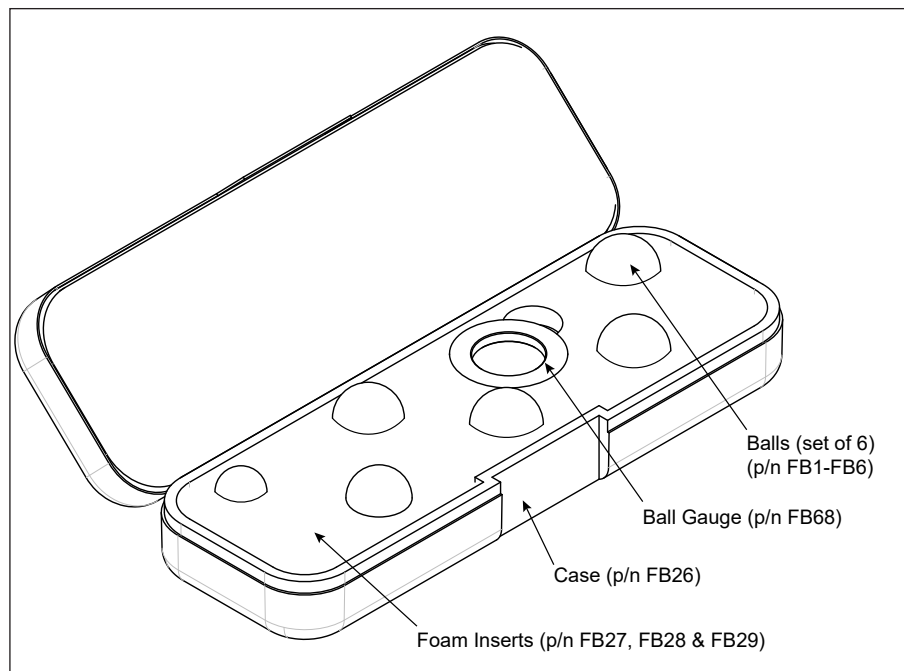

Figure 1

NOTES:

Ball diameters, weights, densities and ball constants (forwards and backwards) are listed in the test certificate accompanying the viscometer.

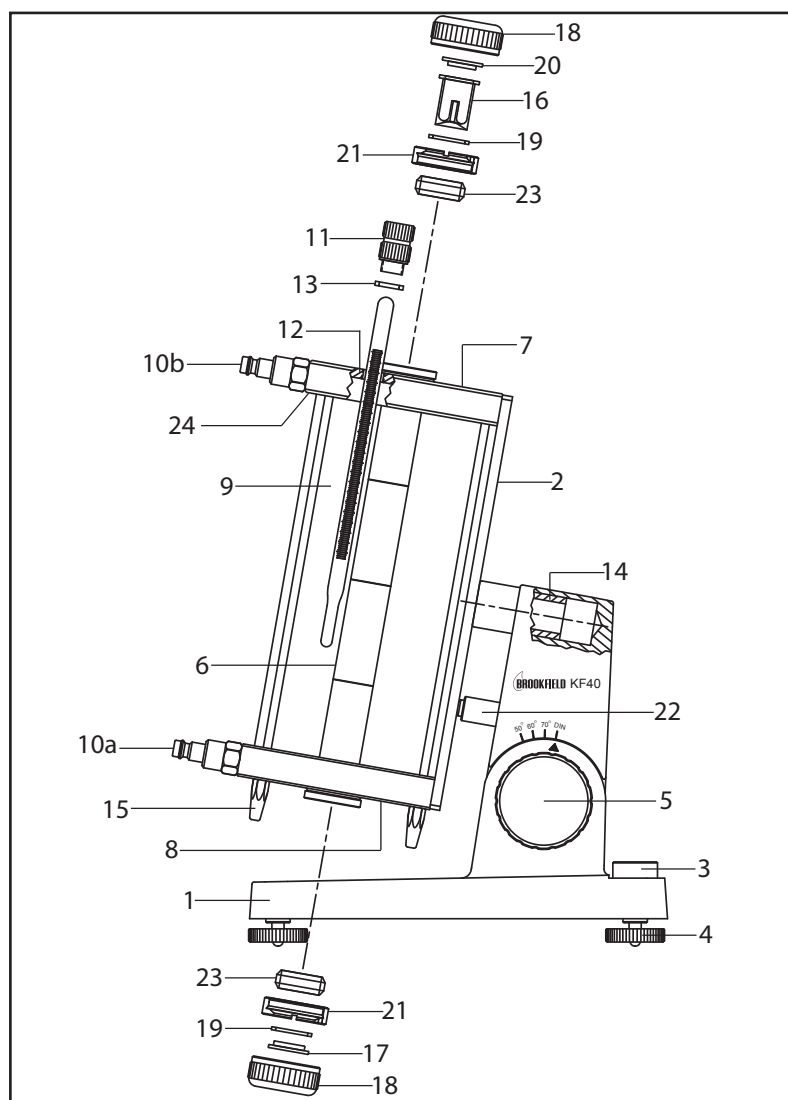

Figure 2: Falling Ball Viscometer KF40

1. Stand - KF40 (Part No. FB204)	13. Thermometer seal , 10mm x 14mm x 2mm (silicone) (Part No. FB32)
2. Viscometer	
3. Bubble Level	14. Bearing for viscometer rotation
4. Leveling Feet (Part No. FB75)	15. Nuts
5. Adjustment screw for angle	16. Upper Locking Plug (Part No. FB64)
6. Glass Tube (15.94mm dia.) with s/n oriented towards the top of the instrument (Part No. FB76)	17. Lower Locking Plug (Part No. FB66)
7. Upper Plate	18. Cap (Part No. FB63)
8. Lower Plate	19. Viscometer seal A 16mm x 20mm (perbunane) (Part No. FB31)
9. Waterbath Jacket (glass) (Part No. FB41)	20. Lid (for upper locking plug) (Part No. FB65)
10a. Inlet port for connection to water bath	21. Falling tube screw fitting (Part No. FB67)
10b. Outlet port for connection to water bath	22. Stop to hold viscometer in position
11. Thermometer screw (Part No. FB42)	23. Seal for falling tube (Part No. FB62)
12. M10x1 Thermometer Attachment Thread	24. Water Jacket Gasket (Part No. FB33)

I.5 Safety Symbols and Precautions

Safety Symbols

The following explains safety symbols which may be found in this operating manual.



Refer to the manual for specific warning or caution information to avoid personal injury or damage to the instrument.

Precautions



If this instrument is used in a manner not specified by the manufacturer, the protection provided by the instrument may be impaired.



This instrument is not intended for use in a potentially hazardous environment.



The user should ensure that the substances placed under test do not release poisonous, toxic or flammable gases at the temperatures to which they are subjected to during the testing.

I.6 Cleaning

Great care should be given to cleaning of the sample tube, the locking plugs and the balls. These components (material: glass, Ni-iron, steel, perbunane, silicone, stainless steel surfaces) must not be damaged or subject to chemical action by the cleaning fluid.

The cleaning procedure is to be carried out in the following sequence:

- The viscometer is pulled out of the bearing guide (14) in the stand by turning it 90° and placed in a suitable collecting basin.
- Unscrew the caps and remove the locking plugs in such a way that the ball does not fall into the collecting basin (possibly damaging the ball). The ball collector (Part No. FB23) is an optional item that can be purchased on request.
- Clean the sample tube using a suitable cleaning agent for the material being measured with the cleaning brush (Part No. FB53).
- There must not be any residue remaining in the sample tube or on the balls after they have been cleaned and are dry. Wipe with a cloth that will not leave fibers, if necessary.
- When cleaning, be careful that the cleaning agent does not come into contact with the equipment outside of the measuring tube.

II. GETTING STARTED

II.1 Choice of Balls

The balls are chosen in such a way that the minimum falling time is not less than what is shown in the table and the maximum falling time is not greater than 300s. The DIN 53015 indicates that a falling time greater than 300s is allowed, but for practical reasons, a shorter test time makes more sense.

Ball No.	Diameter [mm]	Minimum falling time [s]	Lower measuring range limit [mPa·s]	Upper measuring range limit [mPa·s]
1	15.81	60	0.5	10
2	15.60	30	2.5	130
3	15.60	30	20	700
4	15.20	30	200	7800
5	14.00	30	1000	45000
6	11.00	30	5500	70000

The specifications for the ball constant and the ball density are taken from the test certificate which came with the equipment.

The exchange of balls or equipment components between different viscometers is not permitted. Otherwise, the ball constants lose their validity.

When the falling time for the ball is less than the minimum time, turbulence may occur.

II.2 Filling the Sample Tube

To fill the sample tube:

- The sample tube is locked on the lower plate with the lower locking plug, seal, and cap.
- The liquid is filled up to approximately 25mm beneath the top of the sample tube without air bubbles. Use a glass filter to remove any impurities when introducing a liquid into the tube.
- The ball is polished with the leather cloth and fibers are removed with the small cleaning brush, before being inserted into the tube with the ball tweezers. The ball must not be touched after polishing. The ball will travel to the bottom of the tube. Possible air bubbles in the sample, or trapped below the ball, are removed with a suitable rod, by rotating the ball.
- Insert the upper locking plug with seal into the sample tube. In so doing, the sample must enter the inside of the upper locking plug through the opening. The upper locking plug must

not be filled more than half way with the sample in order to minimize pressure build-up due to the air bubbles. Due to the design of the upper locking plug, air bubbles cannot get into the sample tube.

- The sample must be free of air bubbles between the two locking plugs. The lid of the upper locking plug is attached and the temperature control (desired test temperature) must be achieved. **After proper temperature control is achieved, the upper cap is screwed on.**

 **Do not heat the sample with the upper lid attached as pressure may build in the tube.**

NOTE: Gas bubbles can be removed by warming up the sample for a short time (approximately 20 degrees above the measuring temperature with the upper locking plug removed) or by lightly tapping on the lid of the upper locking plug.

II.3 Temperature Control of the Sample

The following are suggested working fluids for the circulating temperature bath:

Temperature Range	Bath Working Fluids	Tubing
-5 to +20°C	Water (distilled) - glycol-mixture; mixed in accordance with the manufacturer's instructions for the temperature range	Insulated Latex tubing, secured with tube band clips
+1°C to +80°C	Distilled water	Latex tube
+80°C to +150°C	Transparent thermostatic oil	Insulated Fluran tube, secured with tube band clips

The inlet and outlet ports should be oriented in the following manner. During initial fill of water jacket, the inlet will be at the bottom of the viscometer and the outlet will be at the top.

The tubing from the circulating bath should be pushed tightly onto the viscometer tubes. By pulling gently, check whether the tubing is firmly attached. Tubing and circulating baths are available on request from AMETEK Brookfield or your local authorized dealer. If the water bath jacket has condensation on the glass, rub with alcohol.

The sample tube is sealed with the upper cap after temperature set point has been achieved. Allow 30 minutes for thermal equilibrium.

Falling ball viscometers provide precise temperature control for the sample. By measuring your sample at multiple temperatures, you can determine the temperature viscosity curve.

II.4 Measuring the Falling Time

Before beginning the measurement, the upper cap must be loosened (unscrewed) again to let off possible pressure.

The time which the balls take to run between the top and bottom ring marks in the sample tube is determined with a stop watch (resolution 0.01s).

It is recommended that you record the passage of the lower ball point using the ring marks as follows. Position your eyes at the same height as the ring marks so that these appear as a line. A dark paper, placed behind the viscometer with its edge at the same height as the ring mark, shows the ball periphery more distinctly.

With dark liquids, you can better observe the ball in the sample tube by looking from behind the instrument.

Possible variations in the measuring times may be due to impurities in the sample, air bubbles or the fact that it has not been brought to the right temperature (insufficient temperature control). Even 0.1°C change in temperature is clearly measurable. The first forward and return passage of the ball can be used to achieve a thorough mixing (temperature equalization) of the sample before running the viscosity test.

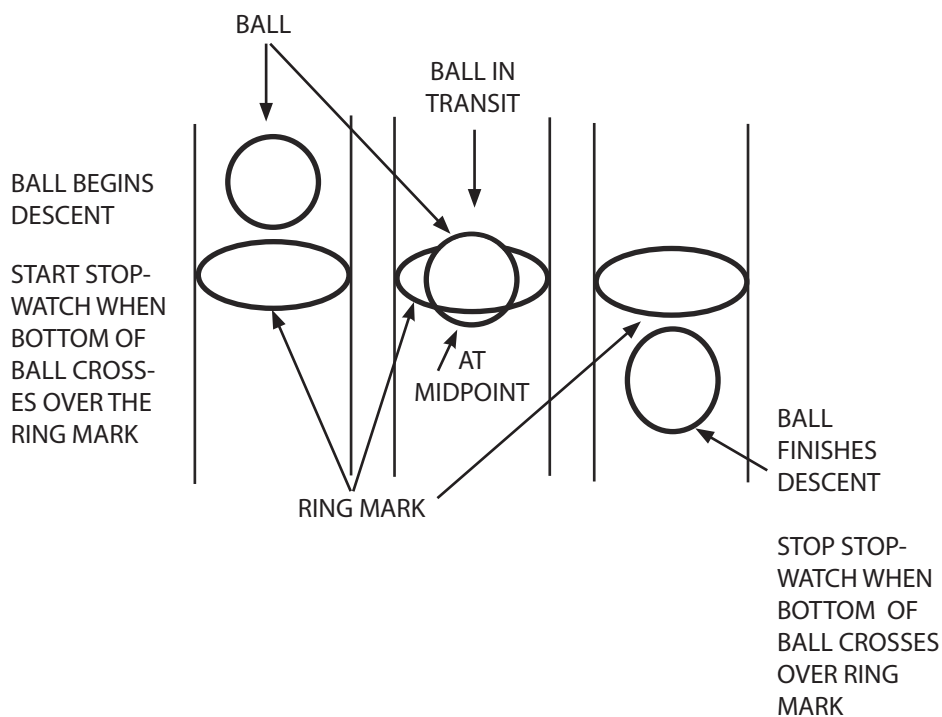

III. CALCULATIONS

III.1 Dynamic Viscosity

With Newtonian liquids absolute values of the dynamic viscosity are calculated, where as, for non-Newtonian liquids, relative values of the dynamic viscosity (apparent viscosity) are calculated.

The dynamic viscosity is calculated according to the following equation:

Equation 1:

$$\eta = t(\rho_1 - \rho_2)K \cdot F$$

where:

- η dynamic viscosity [mPa·s]
- t traveling time of the ball [s]
- ρ_1 density of the ball according to the test certificate [g/cm³]
- ρ_2 density of the sample [g/cm³]
- K ball constant according to test certificate [mPa·cm³/g]
- F working angle constant

Angle of inclination a (applied to the level)	Working angle constant F
80° (DIN)	1.0
70°	0.952
60°	0.879
50°	0.778

The density and ball constant are each stated in the test certificate.

Consideration for buoyancy of the ball in the sample is accounted for by means of $(\rho_1 - \rho_2)$ in equation (1).

The density of the sample can be determined by:

- referring to the material specifications from the manufacturer of the fluid
- measuring with a densitometer

Note: Be sure to measure the sample density at the same temperature at which the viscosity will be measured.

As $\rho_1 - \rho_2$ becomes small, a higher resolution on density measurement is required. The density of the sample to be determined to 0.001g/cm³ (3rd decimal position) for the glass balls and 0.01g/cm³ (2nd decimal position) for the metal balls.

III.2 Kinematic Viscosity

The conversion of the dynamic viscosity into the kinematic viscosity is accomplished using the following equation:

Equation 2:
$$v = \frac{\eta}{\rho_2}$$

v Kinematic viscosity [mm²/s]
 η Dynamic viscosity [mPa•s]
 ρ_2 Density of the sample [g/cm³]

IV. DETERMINATION OF THE NON-NEWTONIAN BEHAVIOR

Non-Newtonian behavior can be determined when different measurement times are recorded with repeated tests.

IV.1 Thixotropy/Rheopexy

Thixotropy (rheopexy) is indicated if the traveling times for a ball decreases (increases) when repeated measurements are made on the same volume of sample.

NOTE: If temperature control is not done correctly, thixotropy or rheopexy can be inferred by mistake.

Rotational or Capillary Viscometers should be used for better determination of flow behavior.

IV.2 Structural Viscosity (Pseudoplasticity and Dilatancy)

Using the KF40 Falling Ball Viscometer at different angles may serve to determine pseudoplastic or dilatant behavior for non-Newtonian liquids. If the sample is non-Newtonian, the travel time of the ball multiplied by the sine of the working angle for the KF40 will not remain constant. This infers non-Newtonian flow behavior. For pseudoplasticity, the calculated value decreases; for dilatancy, it increases.

NOTE: If temperature control is not done correctly, pseudoplasticity or dilatancy can be inferred by mistake.

Details about the relative values for pseudoplasticity and dilatancy are related to the diameter of the ball and the working angle.

More sophisticated equipment, like rotational viscometers/rheometers, should be used for detailed examination of non-Newtonian materials.

Appendix A - Maintenance

A.1 Exchanging the Sample Tube



Caution Glass Components. Excessive force may result in broken glass.

1. Loosen the two set screws of the sample tube screw fittings (above and below).
 - a. Empty the water jacket and sample tube. Make sure the water jacket is clean on the inside surface before reassembling.
2. Unscrew both of the sample tube screw fittings using a ring nut key.
3. Pull off the rubber seal (washer) on one end of the sample tube.
4. Pull the sample tube out at the other end.
5. Insert the new sample tube and also wet the sample tube gaskets and washers.
6. Assemble the sample tube in the reverse order. Observe that the ends of the sample tube project evenly from the upper and lower plates.
7. Re-calibrate all the ball constants according to Appendix B.

A.2 Exchanging the Water Bath Jacket



Caution Glass Components. Excessive force may result in broken glass.

1. Remove the sample tube.
 - a. Empty the water jacket and sample tube. Make sure the water jacket is clean on the inside surface before reassembling.
2. Unscrew the upper and lower plates on the connecting bar.
3. Unscrew the three lower nuts on the viscometer.
4. Replace rubber washers and insert the new water bath jacket.
5. Put on the upper plate and screw down the nuts evenly.
6. Fix the lower plate on the lower connecting bar.
7. Assemble the sample tube.
8. Calibrate all the ball constants according to Appendix B.

A.3 Exchanging the Ball or the Viscometer

1. Exchange the balls or viscometer.
2. Re-calibrate the ball constants according to Appendix B.

Appendix B - Calibration of the Ball Constants

Brookfield's certification of the instrument is performed with Ball #2 and Ball #3 as well as using the Cannon N44 viscosity standard with a nominal value of 92 mPa·s at 20°C.

Re-calibration of the ball constants is required by the operator if:

1. changes in the sample tube or water jacket were made
2. one or more balls were replaced

The calibration requires the use of a Newtonian mineral oil viscosity standard. Choice of the viscosity standard is according to the ball. Use the appropriate Cannon or Brookfield viscosity standard that falls within the viscosity measurement range.

BALL NO.	1	2	3	4	5	6
Recommended Viscosity Standards (cP, mPa·s)	Cannon	Cannon	Cannon	Cannon	Cannon	N/A
	S3	N10	N100	N350	N1000	N/A
	3.9 cP @ 20°C	21 cP @ 20°C	283 cP @ 20°C	830 cP @ 20°C	2900 cP @ 20°C	N/A

The calibration is made according to the method in DIN 53015 at 20°C ± .05°C. A suitably calibrated thermometer can be obtained from your local authorized dealer, on request.

Ball #6 is not recommended for use in performing a calibration check.

The ball constants are determined from (5) running times, in both forward and reverse direction.

The ball constant is calculated according to the following equation:

Equation 3:
$$K = \frac{\eta}{(\rho_1 - \rho_2) \cdot t}$$

- t Mean value from 5 running times [s]
- η Dynamic viscosity of the calibrating fluid [mPa·s] at 20°C ± .05 C
- ρ₁ Density of ball [g/cm³]
- ρ₂ Density of calibrating fluid [g/cm³]

Note: Be sure to measure the sample density at the same temperature at which the viscosity will be measured.

The expected value of the constant should be similar to the constant stated in the test certificate.

For Ball No. 6, the ball constant changes insignificantly as a function of the falling tube diameter and diameter of the ball, so that the ball constant is calculated according to the following equation:

Equation 4:

$$K_6 = 1.4057(D - d_6) \left(0.75042 + 1.82637 \frac{d_6}{D} \right)$$

- D Falling tube diameter (15.94 mm)
- d₆ Diameter of Ball No. 6 (see calibration certificate)
- K₆ Ball constant of Ball No. 6

Appendix C - Online Help and Additional Resources

www.brookfieldengineering.com

The Brookfield website is a good resource for additional and self-help whenever you need it. Our website offers a selection of “how-to” videos, application notes, conversion tables, instructional manuals, material safety data sheets, calibration templates and other technical resources.

www.youtube.com/user/BrookfieldEng

Brookfield has its own YouTube channel. Product and Application Videos can be found here.

Article Reprints

Available in Print Only

- Brookfield has an extensive library of published articles relating to viscosity, texture and powder testing. Due to copyright restrictions, these articles cannot be emailed. Please request your hard copy of articles by calling our customer service department directly or by emailing: MA-MID.sales@ametek.com.

Available Online

- Brookfield has a growing number of published articles that can be downloaded directly from the Brookfield website. These articles can be found on our main site by following this path: www.brookfieldengineering.com/learning-center/articles-and-technical-papers

More Solutions to Sticky Problems

Learn more about viscosity and rheology with our most popular publication. This informative booklet will provide you with measurement techniques, advice and much more. It's a must-have for any Brookfield Viscometer or Rheometer operator. More Solutions is available in print and also as a downloadable pdf on the Brookfield website by following this path:

<http://www.brookfieldengineering.com/support/documentation>

Training/Courses

Whether it is instrument-specific courses, training to help you better prepare for auditing concerns, or just a better understanding of your methods, who better to learn from than the worldwide leaders of viscosity measuring equipment? Visit our [Services](#) section on our website to learn more about training.

Appendix D - Warranty and Repair Service

Brookfield Viscometers are guaranteed for one year from date of purchase against defects in materials and workmanship. They are certified against primary viscosity standards traceable to the National Institute of Standards and Technology (N.I.S.T.). The Viscometer must be returned to AMETEK Brookfield or to the authorized dealer from whom it was purchased for a warranty evaluation. Transportation is at the purchaser's expense. The Viscometer should be shipped in its carrying case together with all spindles originally provided with the instrument. If returning to Brookfield, please contact us or go on-line for a return authorization number prior to shipping.

For a copy of the Repair Return Form, go to the Brookfield website:
www.brookfieldengineering.com/services/downloads/repair-forms

For repair or service in the **United States** return to:

AMETEK Brookfield
11 Commerce Boulevard
Middleboro, MA 02346 U.S.A.
Telephone: (508) 946-6200 Fax: (508) 923-5009
www.brookfieldengineering.com

For repair or service outside the United States, consult Brookfield or the authorized dealer from whom you purchased the instrument.

For repair or service in the **United Kingdom** return to:

AMETEK (GB) Limited
Brookfield Technical Centre
Stadium Way
Harlow, Essex CM19 5GX, England
Telephone: (44) 1279/451774 Fax: (44) 1279/451775
www.brookfieldengineering.uk

For repair or service in **Germany** return to:

AMETEK GmbH
Hauptstrasse 18
D-73547 Lorch, Germany
Telephone: (49) 7172/927100 Fax: (49) 7172/927105
www.brookfieldengineering.de

For repair or service in **China** return to:

AMETEK Commercial Enterprise (Shanghai) Co., Ltd. Guangzhou Branch
Room 810 Dongboa Plaza, No. 767 East Dongfeng Road
Guangzhou, 510600 China
Telephone: (86) 20/3760-0548 Fax: (86) 20/3760-0548
www.brookfieldengineering.cn

On-site service at your facility is also available from Brookfield. Please contact our Service Department in the United States, United Kingdom, Germany or China for details.