

Ultrasonic Flowmeter Instruction Manual

Model: D118



Update	Revision	3.0.0
Record	Date	11.2015

Notice

Thank you for choosing the D118 Ultrasonic Flowmeter with ARM.FPGA chip and low-voltage wide-pulse sending technology.

This instruction manual contains important information. Please read carefully before the operation of the flowmeter, avoiding damaging flowmeter and improper use.

This instruction manual will introduce how to use the flowmeter step-by-step, including product component, installation, wiring, quick setup etc. to make it easier to operate.

Understanding more about the menu settings can fulfill your higher requirements with the flowmeters' powerful function option and output function.



Warning

May cause injury.





Attention

May damage the flow meter.

Some of the instructions may be different to the flowmeters you purchased, depending on configuration requirements, otherwise, there is no indication about the product design and upgrade requirement in the instructions, subject to the flowmeter display, please refer to the version number, as well as the appendix.

Product Components

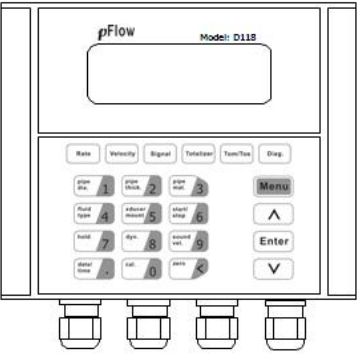
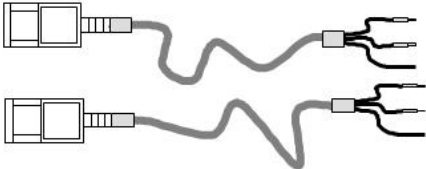
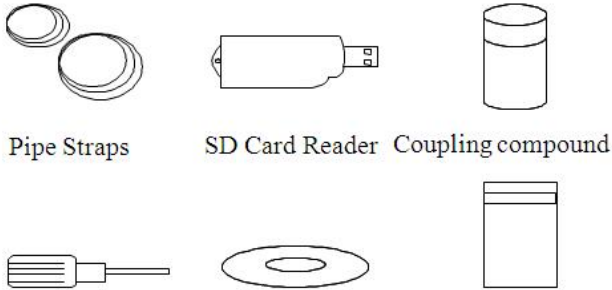
Inspection should be made before installing the Flowmeter. Check to see if the spare parts are in accordance with the packing list. Make sure that there is no damage to the enclosure due to a loose screw or loose wire, or other damage that may have occurred during transportation. Any questions, please contact your representative as soon as possible.

Transmitter	Transducers
	
Accessories	Documents
 <p>Pipe Straps</p> <p>SD Card Reader</p> <p>Coupling compound</p> <p>Screw Driver</p> <p>Software</p> <p>Screws and plastic bushings</p>	 <ol style="list-style-type: none"> 1. Instruction Manual 2. Packing List 3. Certified 3-Point Factory Calibration 4. Position drawing 5. Application Worksheet

Content

1. Transmitter Installation and Connection.....	7
1.1 Inspection Prior to Transmitter Installation.....	7
1.2 Wire Connecting.....	8
1.2.1 Power Supply Option.....	8
1.2.2 Transmitter Wiring.....	8
1.3 Powering On.....	9
1.4 Keypad Functions.....	9
1.5 Keypad Operation.....	9
1.6 Flowmeter Window Descriptions.....	10
2. Pipe Parameter Entry Shortcuts.....	11
2.1 Dual Function Keys Menu Description.....	11
2.2 Examples.....	13
2.3 Measurement Site Selection.....	14
3. Transducer Installation.....	16
3.1 Transducer Installation.....	16
3.1.1 Transducer Spacing.....	16
3.1.2 Transducer Mounting Methods.....	16
3.1.3 V Method.....	16
3.1.4 Z Method.....	16
3.1.5 N Method (not commonly used).....	17
3.2 Transducer Mounting Inspection.....	17
3.2.1 Signal Strength.....	17
3.2.2 Signal Quality (Q value).....	17
3.2.3 Total Time and Delta Time.....	17
3.2.4 Transit Time Ratio.....	18
3.2.5 Warnings.....	18
4. Operating Instructions.....	19
4.1 System Normal Identification.....	19
4.2 Low Flow Cutoff Value.....	19
4.3 Zero Settings.....	19
4.4 Scale Factor.....	19
4.5 System Lock.....	19
4.6. 4 ~ 20mA Current Loop Output.....	20
4.7 Frequency Output.....	20
4.8 Totalizer Pulse Output.....	20
4.9 Alarm Programming.....	21

4.10 Batch Controller	21
4.11. 4-20mA Analog Output Calibration.....	22
4.12 SD Card Operation	22
4.12.1 Specifications.....	22
4.12.2 Install or Remove the SD Card while the Meter is Powered On	23
4.12.3 Reading the SD Data Internally with the Instrument Powered On	23
4.12.4 Reading the SD Data Externally	26
4.13 ESN	26
5. Windows Display Explanations.....	27
5.1 Windows Display Codes.....	27
5.2 Display Explanations	29
6. Error Diagnoses	51
6.1 Table 1. Error Codes and Solutions (During Operation)	51
6.2 Frequently Asked Questions and Answers	52
7. Product Overview	53
7.1 Introduction	53
7.2 Features of D118	53
7.3 Theory of Operation	53
7.4 Applications	54
7.5 Specifications	55
8. Appendix1 - W210 Insertion Transducer	54
8.1 Overview	54
8.2 Measurement Point Selection	54
8.3 Determining Transducer Spacing & Transducer Installation.....	54
8.4 Transducer Mounting Methods.....	58
8.5 Z Mounting Method	58
8.6 Pipe Parameter Entry Shortcuts.....	58
9. Appendix2 –W110 Insertion Transducer	60
9.1 Overview	60
9.2 Measurement Point Selection	60
9.3 Determining Transducer Spacing and Installation Method	60
9.4 Menu Setup Instructions.....	61
9.5 Installation Method.....	62
9.5.1 Z Mounting Method.....	62
9.5.2 V Mounting Method	63
9.5.3 W Mounting Method	63
10. Appendix3 – WH Insertion Transducer	64
10.1 Overview	64

- 10.2 Measurement Point Selection64
- 10.3 Determining Transducer Spacing & Transducer Installation.....64
- 10.4 WH Type Insertion Transducer Pipe Parameter Entry Shortcuts.....65
- 10.5 WH Type Transducer Mounting Methods67
 - 10.5.1 Z Mounting Method.....67
 - 10.5.2 V Mounting Method67
- 11. Appendix4 – Serial Interface Network Use and Communications Protocol.....68
 - 11.1 Overview68
 - 11.2 Serial Port Definitions68
 - 11.3 Direct connection via RS232 to the host device69
 - 11.4 Communications Protocol and the Use.....69
 - 11.4.1 FUJI Protocol.....69
 - 11.4.2 MODBUS Communication Protocol73
- 12. Appendix5–RTD Module and PT1000 Wiring (Module Optional)77
 - 12.1 RTD Energy Meter Function77
 - 12.2 Wiring (PT1000).....77
 - 12.3 Energy Measurement Methods77
 - 12.4 Temperature Calibration Methods78
- 13. Appendix6– Energy Meter.....79
 - 13.1 Energy Meter Function79
 - 13.2 Wiring79
 - 13.3 Energy Calculation Method79
 - 13.4 Set Temperature Value Range.....80
- 14. Appendix7- Flow Application Data.....81
 - 14.1 Sound Velocity and Viscosity for Fluids Commonly Used.....81
 - 14.2 Sound Velocity for Various Materials Commonly Used.....81
 - 14.3 Sound Velocity in Water (1 atm) at Different Temperatures.....82

Update Information:

1. Transmitter Installation and Connection

1.1 Inspection Prior to Transmitter Installation

You will find a "Position Drawing" in the packing. Please use it as a template in the place that you are going to install the flowmeter. Then drill 4 installation holes at the screw position shown on the drawing with the 5.5mm drill.

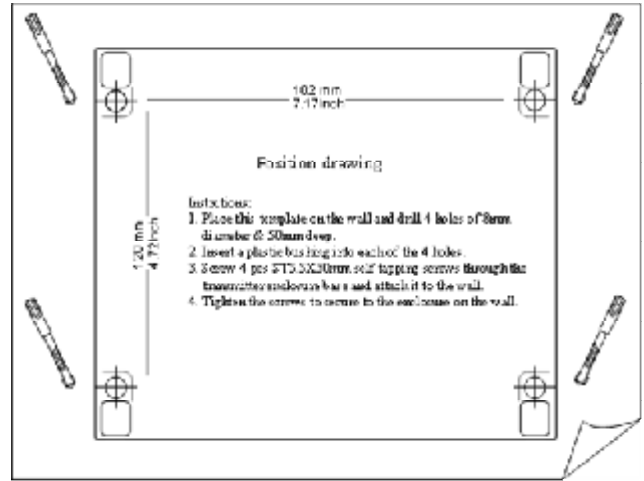

Take out the enclosed screws and plastic bushings. Insert the plastic bushings into the installing holes. Then open the two aluminum pieces on the two sides of the top cover. Put the flowmeter into the position and screw it in.

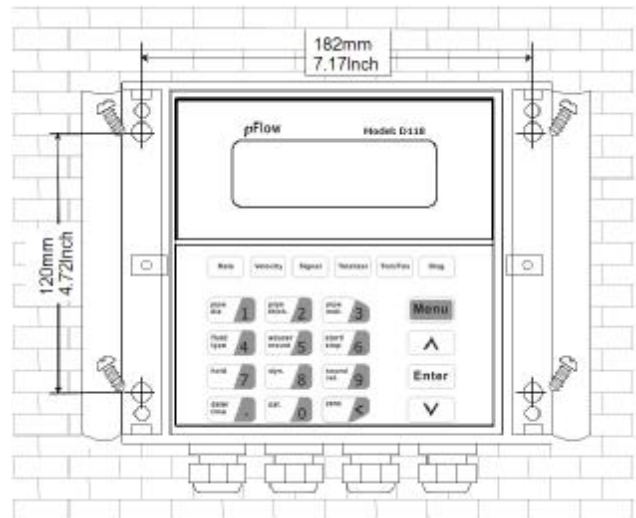

Attention

When installing please ensure the front cover is secure and will not fall open.

1.2 Wire Connecting

1.2.1 Power Supply Option

Customers should pay special attention to specify the desired power supply when wiring. Factory standard power supply is 90 ~ 245 VAC.

To ensure the transmitter can work normally, please pay attention to the followings when wiring:

Ensure that power connections are made in accordance with the specifications shown on the transmitter.

Transmitters can be powered by two different power supplies: 90 ~ 245VAC or 10-36VDC.

1.2.2 Transmitter Wiring

Once the electronics enclosure has been installed, the flowmeter wiring can be connected.

Open the case, you will find the Power board wiring ports, from left to right, are as follows;

Connect to AC power (90-245V), DC power (10-36V), Relay Output, OCT Output, Analog Input, Transducer wiring, 4-20mA Output, RS232 Output, RS485 Output.

For double-shielded transducer cable: "-" on the black wire, "+" on the red wire and "shield" on the shield wire.

Refer to the below diagram for specific connection:

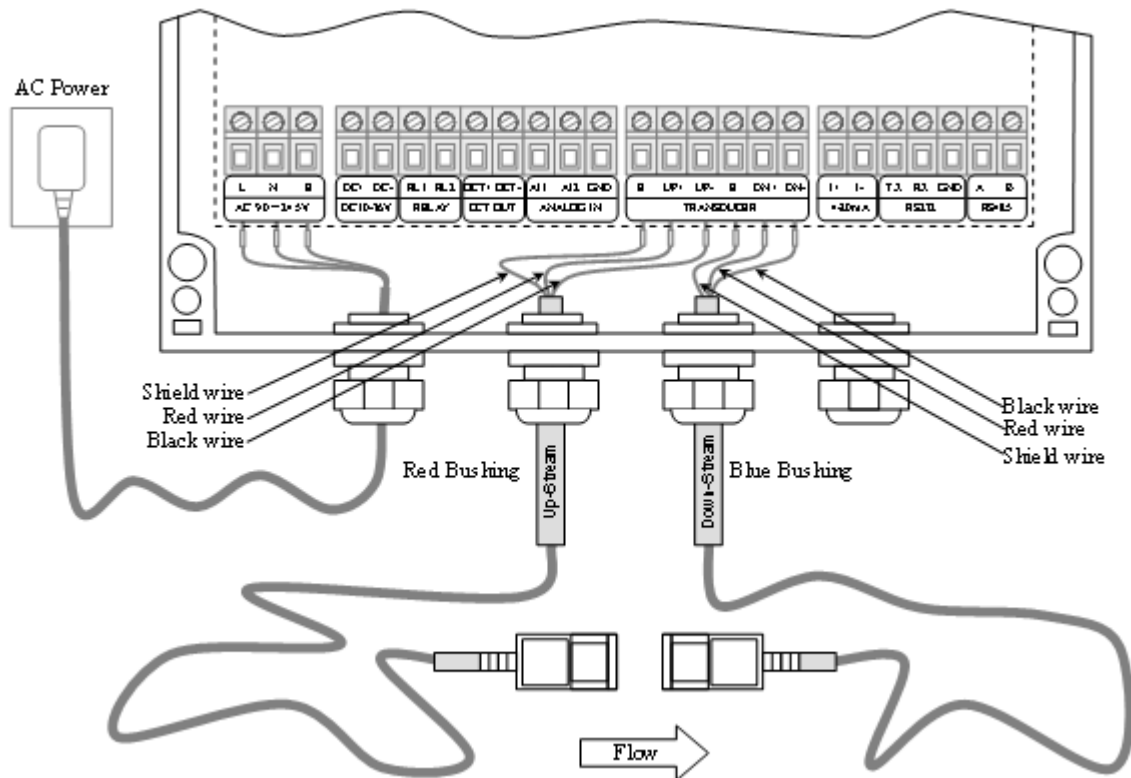

Warning

Wire when it is power-off. Reliable grounding must be taken for the instrument before installation and use .

Use either AC or DC power supply. Do not connect them both at the same time.

1.3 Powering On

As soon as the flowmeter is switched on, the system will run automatically according to the last input parameters. If the installation is accomplished when system is switched on, gain adjustment can be monitored in Window M01. After code "*R" are displayed on the upper left corner of the screen, the system will activate the normal measurement condition automatically. It is indicated by code "*R" on the upper left corner of the screen.

If it is the first time to use or install on a new site, the customer need to input the new installation site parameters. Any parameters which are set by user will be saved permanently until they are changed by the user.

When the user modifies the parameters and removes the transducers, the meter will recalculate automatically, and operate normally with the parameters.

The flowmeter can always complete all tasks at the same time. The tasks (Including measurement, output, etc) will be carried out as usual, no matter in which display window. The system will default to the last window settings and automatically display them when the flowmeter is power - on.



1.4 Keypad Functions

Follow these guidelines when using the dual function keypad (Refer to Keypad Figure):

 Input Numbers or Menu Code.

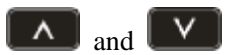
 Backspace or delete characters to the left.

 Return to the last menu or open the next menu. Acts as "+" and "-" are used to enter numbers.

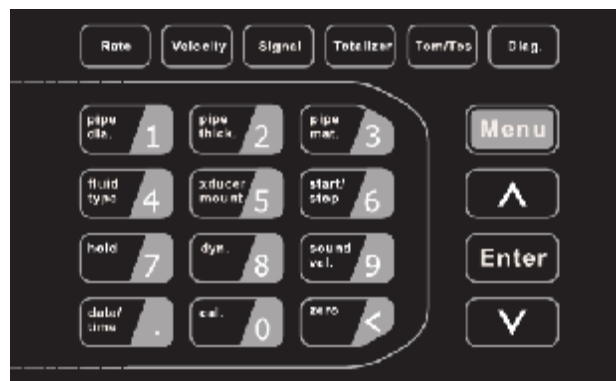

 Select a menu. Press this key first, then input two menu numbers to display the selected menu. For example, To Input a pipe outside diameter, press  keys, where "11" is the window ID to display the parameter for pipe outside diameter.

 are shortcuts to the windows for Flow Rate, Velocity, Signal Strength and Signal Quality, Totalizer, Velocity, Transit Time Ratio, and System Error Codes.





1.5 Keypad Operation

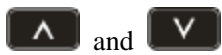

The flow meter adopts the window software design to consolidate or subdivide all of the parameters entered, the instrument setup and measurement result displays into more than 100 independent windows. The operator can input parameters, modify settings or display measurement results by "visiting" a specific window. These windows are arranged by 2-digit serial numbers (including "+" sign) from 00 ~ 99, then to +0, +1, etc. Each window serial number, or so-called window ID code, has a defined meaning. For example, Window M11 indicates the parameter input for pipe outside diameter, while Window M25 indicates the mounting spacing between the transducers, etc. (Refer - Windows Display Explanations).

The keypad shortcut to visit a specific window is to press the  key at any time, then input the 2-digit window ID code. For example, to input or check the pipe outside diameter, just press the  keys for window ID code 11.









Another method to visit a particular window is to press  keys to scroll the screen. For example, if the current window ID code is M02, press  key to enter Window M01, press the  button again to

enter Window M00; then, press the  key to back Window M01, and press the  key again to enter Window M02.





Windows are separated into three types: (1) Data Type, such as M11, M12; (2) Option Type, such as M14; (3) Pure Display Type, such as M01, M00.









You can check the corresponding parameters by visiting the Data Type Windows. If you want to modify the parameters, input the digits and press  or press  first, input the digits then press  again to confirm.

Example1: To enter a pipe outside diameter of 200, the procedure is as follows:

Press    keys to enter Window M11 (the numerical value displayed currently is a previous value). Now press  key. The symbol ">" and the flashing cursor are displayed at the left end of the second line on the Screen. Then input the parameters; or do not press the  key, directly enter    .

Pipe Outer Diameter
>_



You can check the selected option by visiting Option Type Windows. If you want to modify it, you must press  first, the symbol ">" and the flashing cursor are displayed at the left of the Screen. Operator can use the  and  to scroll the screen and get the required value then press  to confirm; or enter the corresponding value option directly and press  to confirm.

For example, if the pipe material is "Stainless Steel", Press    to enter Window M14, press  to modify the options. Select the "1. Stainless Steel" option by pressing  and , then press  to confirm the selection; It is possible to press  key to change the selection and wait until "1.Stainless Steel" is displayed on the second line of the screen, then press  to confirm.

Pipe Material [14
>1. Stainless Steel

Attention



Generally, press  key first if operator wants to enter "modify" status. If the "modify" is still not possible even after pressing the  key, it means that system is locked by a password. To "Unlock" it, select "Unlock" in Window M47 and enter the original password.

1.6 Flowmeter Window Descriptions

These windows are assigned as follows:

- 00 ~ 09 Display menus: to display flow rate, positive total, negative total, net total, velocity, date & time, present analog output, present operation and flow results today, etc.
- 10 ~ 29 Initial Parameter Setup: to enter pipe outside diameter, pipe wall thickness, fluid type, transducer type, transducer mounting method and spacing, etc.
- 30 ~ 38 Flow Units Options: to select the flow unit such as cubic meter, liter or other units, can turn totalizers

on/off and reset totalizers, etc.

- 40 ~ 51 Setup options: Scale factor, system lock (Window M47), etc.
- 52 ~ 89 Input and output setup: CL mode select, CL 4mA/20mA output value, serial port parameter ,etc.
- 90 ~ 98 Diagnoses: Signal strength and signal quality (Window M90), TOM/TOS*100 (Window M91), flow sound velocity (Window M92), total time and delta time (Window M93), Reynolds number and factor (Window M94), etc.
- +0 ~ -2 Appendix: power on/off time, total working hours, on/off times and a single-accuracy function calculator.



Attention

The other windows for hardware adjustment are reserved by the manufacturer.

2. Pipe Parameter Entry Shortcuts

2.1 Dual Function Keys Menu Description

Press  key.

Display Flow Rate. The function is the same with Window M02.

Flow 0.1129m3/h *R
POS 0x1m3

Press  key.

Display Velocity. The function is the same with Window M01.

Flow 0.1129m3/h *R
Vel 1.0415m/s

Press  key.

Display Signal Strength and Signal Quality. The function is the same with Window M90.

Strength + Quality [90
UP:00.0 DN:00.0 Q=00

Press  key.

Display Net Totalizer. The function is the same with Window M00.

Flow 0.1154m3/h *R
NET 0x1m3

Press  key.

Display Transit Time Ratio. The function is the same with Window M91.

TOM/TOS*100 [91
0.0000%

Press  key.

Display System Error Code. The function is the same with Window M08.

*R-----
System Normal

Press  key.

Enter Pipe Outer Diameter in Window M11.

Pipe Outer Diameter
50 mm

Press  key.
Enter Pipe Wall Thickness in Window M12.

Pipe Wall Thickness
4 mm

Press  key.
Enter Pipe Material in Window M14.

Pipe Material [14
0. Carbon Steel

Press  key.
Enter Fluid Type in Window M20.

Fluid Type [20
0. Water

Press  key.
Enter Transducer Mounting in Window M24.

Transducer Mounting
0. V

Press  key.
Enter to start and stop Manual Totalizer in turn.

60 sec
ON 10.123 m3

Press  key.
Display the Display / Hold Totalizer in turn.

Flow 0.1129 m3/h*R
POS OX1m3

Press  key.
Display Dynamic / Normal Flow Rate and Velocity in turn.

Flow 0.1129 m3/h Dyn
Vel 1.0415 m/s





Press  key.
Enter Fluid Sound Velocity in Window M92.

Fluid Sound Velocity
1443.4 m/s

Press  key
Display Date and Time in Window M60.

YY-MM-DD HH:MM:SS
03-04-04 10:05:04

Press  key

Press  to start Manual Totalizer, then press  to end Manual Totalizer, press  to input Standard Totalizer to get the final K factor. Complete the calibration with pressing  to store.

Manual Calibrate
Press Ent When Ready





Press  key
Input code 1234 to set zero.

Set Zero
Please Enter PW

2.2 Examples





For example, let us you have a pipe of 200mm outer diameter and 6mm wall thickness, measuring medium is water, Pipe Material is carbon steel with no Liner, These parameters should be operated as follows:

Step1. Pipe outer diameter:

Press    keys to enter Window M11, and enter the pipe outside diameter, and then press the  key to confirm.







Pipe Outer Diameter
200 mm

Step2. Pipe wall thickness

Press the    key to enter Window M12, and enter the pipe wall thickness, and press the  key to confirm.

Pipe Wall Thickness
6 mm







Step3. Pipe Material

Press the    keys to enter Window M14, press the  key, press the  or  key to select Pipe Material, and press the  key to confirm.

Pipe Material [14
0. Carbon Steel







Step 4. Liner Material Parameters

(including thickness and sound velocity, if needed):

Press the    key to enter Menu 16, press the  key, use the  or  key to select liner material from the drop-down Menu, and then press the  key.

Liner Material [16
0. None, No Liner







Step 5. Fluid Type

Press the    key to enter Menu 20, press the  key, use the  or  key to select fluid type from the drop-down Menu, then press the  key.

Fluid Type [20
0. Water







Step6. Transducer Type

(The transmitter is available for various transducer types.)

Press the    key to enter Window M23, press the  key, move the  or  key to select transducer type, and press the  key to confirm.

Transducer Type [23
0. Standard





Step 7. Transducer Mounting Methods

Press the    key to enter Menu 24, press the  key, use the  or  key to select transducer-mounting from the drop-down Menu,

Transducer Mounting
0. V

then press the  key.
(Details on Chapter 3.1.2).

Step 8. Adjust Transducer Spacing



Press the     key to enter Menu 25, accurately install the transducer according to the displayed transducer mounting spacing and the selected mounting method.

(Details on Chapter 3.1.1).



Transducer Spacing
160.18 mm

Step 9. Display Measurement Results

Press    to enter Menu 01 to display flow rate. (Subject to the real measurement.)

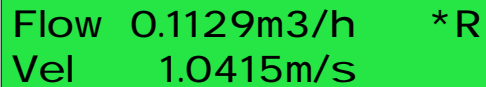

Flow 0.1129m³/h *R
Vel 1.0415m/s

2.3 Measurement Site Selection

The installation of this ultrasonic flow meter is the simplest one of all kinds of flowmeters. Only one suitable measuring site needed, plug the transducers on the pipe and then start the measurement.

When selecting a measurement site, it is important to select an area where the fluid flow profile is fully developed to guarantee a highly accurate measurement. Use the following guidelines to select a proper installation site:

- I Choose a section of pipe that is always full of liquid, such as a vertical pipe with flow in the upward direction or a full horizontal pipe.
- I Ensure enough straight pipe length at least equal to the figure shown below for the upstream and downstream transducers installation. Try to avoid Ensure enough straight pipe length at least equal to the figure shown below for the upstream and downstream transducers installation.
- I On the horizontal pipe, the transducer should be mounted on the 9 and 3 of the pipe, avoiding the position of 6 and 12, in case of the signal attenuation caused by pipe at the bottom sediment or bubble、cavitation on the pipe.
- I Ensure that the measuring site temperature is under the transducer temperature limits.
- I Consider the inside condition of the pipe carefully. If possible, select a section of pipe where the inside is free of excessive corrosion or scaling.
- I Choose a section of sound conducting pipe.

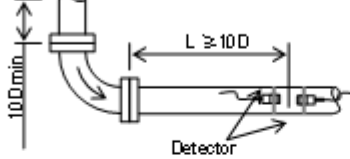
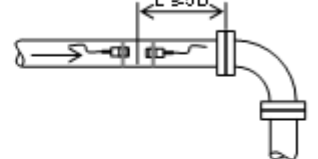
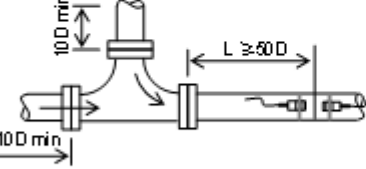
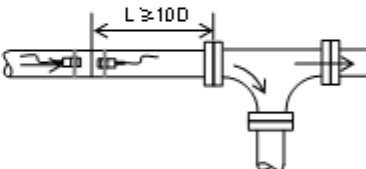
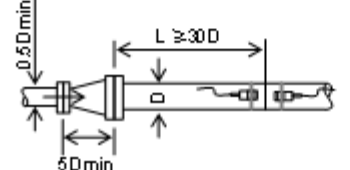
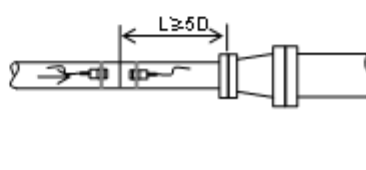
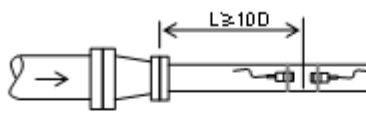
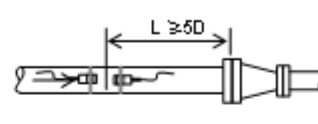
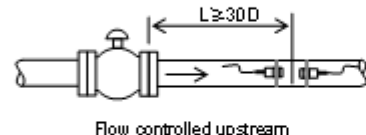
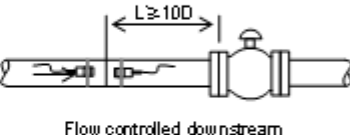
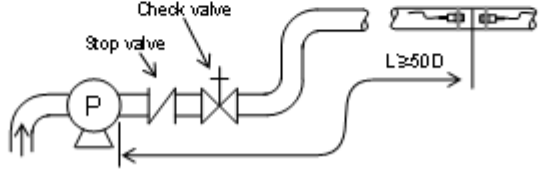
Name	Straight length of upstream piping	Straight length of downstream piping
90° bend		
Tee		
Diffuser		
Reduce		
Valve	 <p data-bbox="574 1176 774 1198">Flow controlled upstream</p>	 <p data-bbox="957 1176 1181 1198">Flow controlled downstream</p>
Pump		

3. Transducer Installation

3.1 Transducer Installation

Before installing the transducers, clean the pipe surface where the transducers are to be mounted. Remove any rust, scale or loose paint and make a smooth surface. Choose a section of sound conducting pipe for installing the transducers. Apply a wide band of sonic coupling compound down the center of the face of each transducer as well as on the pipe surface, ensure there are no air bubbles between the transducers and the pipe wall, and then attach the transducers to the pipe with the straps provided and tighten them securely.

Note: The two transducers should be mounted at the pipe’s centerline on horizontal pipes.

Make sure that the transducer mounting direction is parallel with the flow.

During the installation, there should be no air bubbles or particles between the transducer and the pipe wall. On horizontal pipes, the transducers should be mounted in the 3 o’clock and 9 o’clock positions of the pipe section in order to avoid any air bubbles inside the top portion of the pipe. (Refer to Transducer Mounting). If the transducers cannot be mounted horizontally symmetrically due to limitation of the local installation conditions, it may be necessary to mount the transducers at a location where there is a guaranteed full pipe condition (the pipe is always full of liquid).

3.1.1 Transducer Spacing

The spacing between the ENDS of the two transducers is considered as the standard transducer spacing (Refer to MENU25). After entering the required parameters, Check the data displayed in Window M25 and adjust the transducers spacing according to the data displayed in Windows M25.

3.1.2 Transducer Mounting Methods

Three transducer mounting methods are available. They are respectively: V method, Z method and N method.

The V method is primarily used on small diameter pipes (DN100 ~ 300mm, 4” ~ 12”). The Z method is used in applications where the V method cannot work due to poor signal or no signal detected. In addition, the Z method generally works better on larger diameter pipes (over DN300mm, 12”) or cast iron pipes.

The N method is an uncommonly used method. It is used on smaller diameter pipes (below DN50mm, 2”).

3.1.3 V Method

The V method is considered as the standard method. It usually gives a more accurate reading and is used on pipe diameters ranging from 25mm to 400mm (1” ~ 16”) approximately. Also, it is convenient to use, but still requires proper installation of the transducers, contact on the pipe at the pipe’s centerline and equal spacing on either side of the centerline.

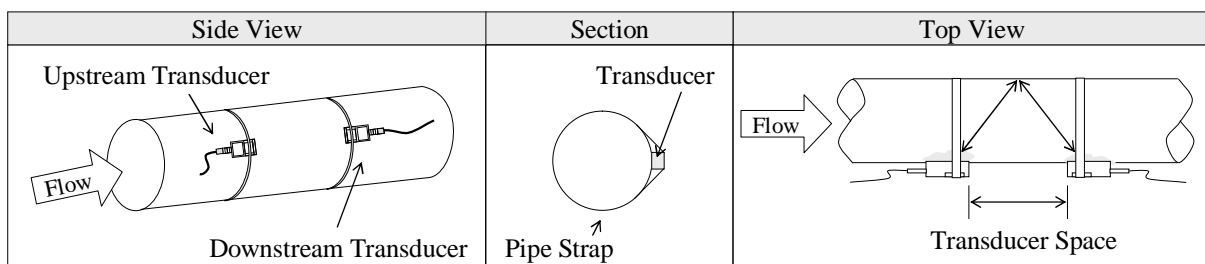

3.1.4 Z Method

The signal transmitted in a Z method installation has less attenuation than a signal transmitted with the V method when the pipes are too large, there are some suspended solid in the fluid, or the scaling and liner are too thick . This is because the Z method utilizes a directly transmitted (rather than reflected) signal which transverses the liquid only once. The Z method is able to measure on pipe diameters ranging from 100mm to 5000mm (4 inch to 200 inch) approximately. Therefore, we recommend the Z method for pipe diameters over 300mm (12 inch).

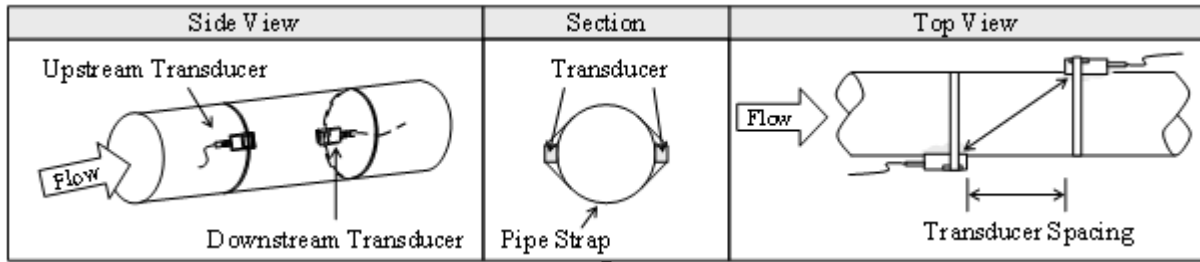

3.1.5 N Method (not commonly used)

With the N method, the sound waves traverse the fluid three times and bounce twice off the pipe walls. It is suitable for small pipe diameter measurement. The measurement accuracy can be improved by extending the transit distance with the N method (uncommonly used).

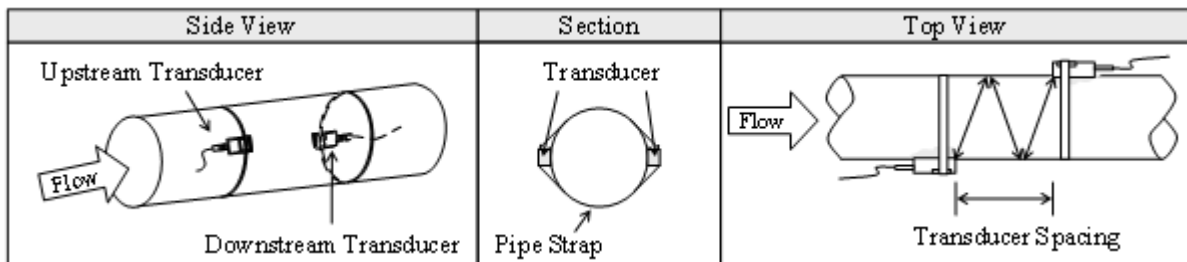

3.2 Transducer Mounting Inspection

Check to see if the transducer is installed properly and if there is an accurate and strong enough ultrasonic signal to ensure proper operation and high reliability of the transducer. It can be confirmed by checking the detected signal strength, total transit time, delta time as well as transit time ratio.

The "mounting" condition directly influences the flow value accuracy and system long-time running reliability. In most instances, only apply a wide band of sonic coupling compound lengthwise on the face of the transducer and stick it to the outside pipe wall to get good measurement results. However, the following inspections still need to be carried out in order to ensure the high reliability of the measurement and long-term operation of the instrument.

3.2.1 Signal Strength

Signal strength (displayed in Window M90) indicates a detected strength of the signal both from upstream and downstream directions. The relevant signal strength is indicated by numbers from 00.0 ~ 99.9. 00.0 represents no signal detected while 99.9 represents maximum signal strength. Normally, the stronger the signal strength detected, the longer the operation of the instrument reliably, as well as the more stable the measurement value obtained.

Adjust the transducer to the best position and check to ensure that enough sonic coupling compound is applied adequately during installation in order to obtain the maximum signal strength.

System normally requires signal strength over 60.0, which is detected from both upstream and downstream directions. If the signal strength detected is too low, the transducer installation position and the transducer mounting spacing should be re-adjusted and the pipe should be re-inspected. If necessary, change the mounting method to be Z method.

3.2.2 Signal Quality (Q value)

Q value is short for Signal Quality (displayed in Window M90). It indicates the level of the signal detected. Q value is indicated by numbers from 00 ~ 99. 00 represents the minimum signal detected while 99 represent the maximum. Normally, the transducer position should be adjusted repeatedly and coupling compound application should be checked frequently until the signal quality detected is as strong as possible.

3.2.3 Total Time and Delta Time

"Total Time and Delta Time", which displays in Window M93, indicates the condition of the installation. The measurement calculations in the Flowmeter are based upon these two parameters. Therefore, when "Delta Time"

fluctuates widely, the flow and velocities fluctuate accordingly, this means that the signal quality detected is too poor. It may be the result of poor pipe-installation conditions, inadequate transducer installation or incorrect parameter input.

Generally, "Delta Time" fluctuation should be less than $\pm 20\%$. Only when the pipe diameter is too small or velocity is too low can the fluctuation be wider.

3.2.4 Transit Time Ratio

Transit Time Ratio indicates if the transducer mounting spacing is accurate. The normal transit time ratio should be 100 ± 3 if the installation is proper. Check it in Window M91.

Attention

If the transit time ratio is over 100 ± 3 , it is necessary to check:





- (1) If the parameters (pipe outside diameter, wall thickness, pipe material, liner, etc.) have been entered correctly,
 - (2) If the transducer mounting spacing is accordance with the display in Window M25,
 - (3) If the transducer is mounted at the pipe's centerline on the same diameter,
 - (4) If the scale is too thick or the pipe mounting is distorted in shape, etc.
-

3.2.5 Warnings

- (1) Pipe parameters entered must be accurate; otherwise the Flowmeter will not work properly.
- (2) During the installation, apply enough coupling compounds in order to stick the transducers onto the pipe wall. While checking the signal strength and Q value, move the transducers slowly around the mounting site until the strongest signal and maximum Q value can be obtained. Make sure that the larger the pipe diameter, the more the transducers should be moved.
- (3) Check to be sure the mounting spacing is accordance with the display in Window M25 and the transducer is mounted at the pipe's centerline on the same diameter.
- (4) Pay special attention to those pipes that formed by steel rolls (pipe with seams), since such pipe is always irregular. If the signal strength is always displayed as 0.00, that means there is no signal detected. Thus, it is necessary to check that the parameters (including all the pipe parameters) have been entered accurately. Check to be sure the transducer mounting method has been selected properly, the pipe is not worn-out, and the liner is not too thick. Make sure there is indeed fluid in the pipe or the transducer is not too close to a valve or elbow, and there are not too many air bubbles in the fluid, etc. With the exception of these reasons, if there is still no signal detected, the measurement site has to be changed.
- (5) Make sure that the Flowmeter is able to run properly with high reliability. The stronger the signal strength displayed, the higher the Q value reached. The longer the Flowmeter runs accurately, the higher the reliability of the flow rates displayed. If there is interference from ambient electromagnetic waves or the signal detected is too poor, the flow value displayed is not reliable; consequently, the capability for reliable operation is reduced.
- (6) After the installation is complete, power on the instrument and check the result accordingly.

4. Operating Instructions

4.1 System Normal Identification

Press the    keys. If the letter "*R" displays on the screen, it indicates system normal.

If the letter "G" is displayed, it indicates that system is adjusting the signal gain prior to the measurement. Also, it means system normal. Only when the adjustment takes too long without stopping, can system be identified as abnormal.

Letter "I" indicates no signal is being detected. Check the transducer wiring connections are correct, the transducers are installed firmly, etc.

For further information, please refer to "Error Diagnosis".

4.2 Low Flow Cutoff Value

The data in M41 is Low Flow Cutoff Value. If the flow rate falls below the low flow cutoff value, the flow indication is driven to zero. This function can prevent the flow meter from displaying flow as "0" after a pump was shut down, but there is still liquid movement in the pipe, which will result in cumulative error. Generally, 0.01m/s is recommended to enter as the low flow cutoff point.

The low flow cutoff value has no relation to the measurement results once the velocity increases over the low flow cutoff value.

4.3 Zero Settings

Once zero flow occurs, a zero point may indicate on each measuring instrument, but the displayed measuring value is not equal to "0", this value indicates "Zero". To any measuring instrument, the smaller the "Zero" is, the better the quality is. Conversely, if the Zero is too big, that indicates the quality of the instrument is poor.

If the zero set point is not at true zero flow, a measurement difference may occur. The smaller the physical measurement capacity is, the larger the measurement difference from the zero point will exist. Only when zero point reduced to a definite degree, as compared with the physical measurement capacity, can the measuring difference from zero point be ignored.

For an ultrasonic Flowmeter, the measurement error from zero point cannot be ignored under low flow conditions. It is necessary to perform a static zero set calibration to improve low flow measurement accuracy.

Set Zero in Menu42, firstly press  key, and then wait for the processing indication displayed at the lower right corner reducing to be "0". Performing Set Zero in flowing conditions may cause the flow to be displayed as "0". If so, it can be recovered via Menu 43.









4.4 Scale Factor

Scale factor refers to the ratio between "actual value" and "reading value". For example, when the measurement is 2.00, and it is indicated as 1.98 on the instrument, the scale factor reading is 2/1.98. This means that the best scale factor constant is 1. However, it is difficult to keep the scale factor as "1" on the instrument especially in batch productions. The difference is called "consistency".

During operation, there still exists possible difference in pipe parameters, etc. The "scale factor" may be necessary when used on different pipes. Thus, scale factor calibration is specially designed for calibrating the differences that result from application on different pipes. The scale factor entered must be one that results from actual flow calibration. The scale factor can be input in Window M45.

4.5 System Lock

System lock is intended to prevent operation error due to tampering by unauthorized personnel.

Press the     keys, move  or  key to select "Lock", press the  key, enter a 1 ~ 4 numerically long password, and then press the  key to confirm.

Unlock it by using the selected password only. Press   , if "lock" is displayed on the screen,

then press **Enter**, enter the correct password, then press **Enter** to confirm.

Keep the password in mind or recorded in a safe place, otherwise the instrument cannot be used.

4.6. 4 ~ 20mA Current Loop Output

With a current loop output exceeding an accuracy of 0.1%, the flowmeter is programmable and configurable with outputs such as 4 ~ 20mA or 0 ~ 20mA selected in Menu 55. For details, please refer to Menu 55 in "Window Display Explanations".

In Window M56, enter a 4mA flow value. Enter the 20mA flow value in Window M57. For example, if the flow range in a specific pipe is 0 ~ 1000m³/h, enter 0 in Window M56 and 1000 in Window M57. If the flow ranges from -1000 ~ 0 ~ 2000m³/h, configure the 20 ~ 4 ~ 20mA output by selecting in Window M55 when flow direction is not an issue. Enter 1000 in Window M56 and 2000 in Window M57. When flow direction is an issue, module 0 ~ 4 ~ 20mA is available. When the flow direction displays as negative, the current output is in range of 0 ~ 4mA, whereas the 4 ~ 20mA is for the positive direction. The output module options are displayed in Window M55. Enter "-1000" in Window M56 and 2000 in Window M57.

Calibrating and testing the current loop is performed in Window M58. Complete the steps as follows:

Press **Menu** **5** **8** **Enter**, move **^** or **v** to display "0mA", "4mA", "8mA", "16mA", "20mA" readings, connect an ammeter to test the current loop output and calculate the difference. Calibrate it if the difference is not within tolerance. Refer to Section 4.11 for Current Loop Verification.

Check the present current loop output in Window M59 as it changes along with change in flow.

4.7 Frequency Output

The flowmeter is provided with a frequency output transmitter function. The high or low frequency output displayed indicates the high or low flow rate reading. The user can reset the frequency output as well as flow rate as the user's actual requirements.

For example: if a pipe flow range is 0 ~ 3000m³/h, the relative frequency output required is 123 ~ 1000Hz, and the configuration is as follows:

In Window M68 (low limit frequency output flow value), input 0;

In Window M69 (high limit frequency output flow value), input 3000;

In Window M67 (low limit frequency), input 123; in Window M67 (high limit frequency), input 1000.

There is no output circuit specially assigned to frequency output. It only can be transmitted through OCT, i.e. select Window M78 (item "13. FO").

Typical OCT Output wiring diagram as below:

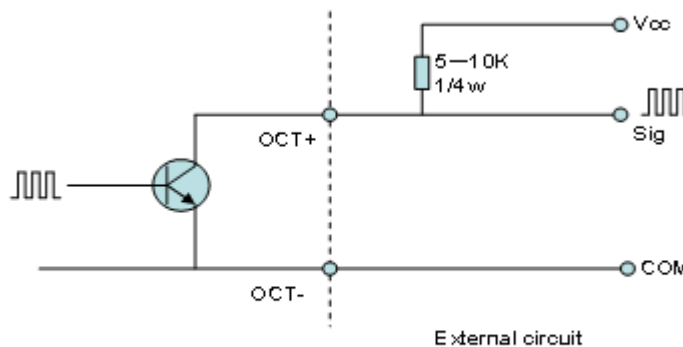

OCT Output wiring diagram

4.8 Totalizer Pulse Output

Each time the flowmeter reaches a unit flow, it may generate a totalizer pulse output to a remote counter.

The totalizer pulse output can be transmitted through OCT or a relay. Therefore, it is necessary to configure OCT

and the relay accordingly. (Please refer to Window M78 and M79). For example, if it is necessary to transmit the positive totalizer pulse through a relay, and each pulse represents a flow of 0.1m^3 , the configuration is as follows:

In Window M32, select the totalizer flow unit "Cubic Meters (m^3)";

In Window M33, select the scale factor "x0.1";

In Window M79, select "9. Positive totalizer pulse output";



Attention

Make sure to select a appropriate totalizer pulse. If the totalizer pulse is too big, the output cycle will be too long; if the totalizer is too small, the relay will operate too faster, you may shorten the life of the relay, as well as skip some pulses. The totalizer is recommended to transmit within the range of 1 ~ 60 pulse per second.

4.9 Alarm Programming

The on-off output alarm is generated through OCT or transmission to an external circuit by opening or closing a relay. The on-off output signal is activated under the following conditions:

- (1) Signal not detected;
- (2) Poor signal detected;
- (3) The flowmeter is not ready for normal measurement;
- (4) The flow is in the reverse direction (back flow).
- (5) The analog outputs exceed span by 120%.
- (6) The frequency output exceeds span by 120%.
- (7) The flow rate exceeds the ranges configured (Configure the flow ranges using the software alarm system. There are two software alarms: Alarm#1 and Alarm #2. The lower limit value for Alarm#1 is configured in Window M73, and the upper limit value is configured in Window M74. As for Alarm#2, the lower limit value is in M75 and the upper one is in Window M76).

Example 1: When flow rate exceeds $300 \sim 1000 \text{m}^3/\text{h}$, in order to program the relay output alarm, Complete the steps as follows:

- (1) In Window M73, input 300;
- (2) In Window M74, input 1000;
- (3) In Window M79, select item 6: "6. Alarm #1 limit exceed".

Example 2: To program OCT output alarm signal, when flow rate exceeds $100 \sim 500 \text{m}^3/\text{h}$; and to relay output alarm signal, when flow rate exceeds $600 \sim 1000 \text{m}^3/\text{h}$, complete the steps as follows :

- (1) In Window M73, input 100;
- (2) In Window M74, input 500;
- (3) In Window M75, input 600;
- (4) In Window M76, input 1000;
- (5) In Window M78, select item 6: "6. Alarm #1".
- (6) In Window M79, select item 7: "7. Alarm #2".

4.10 Batch Controller

The batch controller is able to perform flow quantity control. The internal batch controller in the flowmeter is able to be controlled through the keypad. The output can be transmitted through OCT or a relay.

In Window M78 (OCT output), M79 (relay output) or M80 (Flow Batch CTRL), select Item 8 "Batch controller" and the OCT or relay output will generate output signals.

Enter the batch value in Window M81. Start the batch controller after that. For details, please refer to "Windows Display Explanations".

4.11. 4-20mA Analog Output Calibration



Attention

Each flowmeter has been calibrated strictly before leaving factory. It is unnecessary to carry out this step except when the current value (detected while calibrating the current loop) displayed in Window M58 is not identical with the actual output current value.

The hardware detect window must be activated prior to calibration the Analog Output. The procedure is as follows:

Press **Menu** **↓** **0** **Enter** to enter password "115800", then press **Enter** to activate the detected menu. With no effect to next power on, this window will close automatically as soon as the power is turned off.

Press **↓** to calibrate the current loop 4mA output. Use an ammeter to measure the output current of current loop. At the same time, press **↑** or **↓** key to adjust the displayed numbers. Watch the ammeter until it reads 4.00. Stop at this point, the 4mA has been calibrated.

Then, press **Enter** to calibrate the current loop 20mA output. The method is the same as 4mA calibration.

The results are automatically saved in EEPROM and won't lose when power off.

4.12 SD Card Operation

4.12.1 Specifications

Data collection interval: any interval settings from 1 to 3600 seconds are OK according to the requirement.

Data content: date and time, flow rate, flow velocity, total flow, positive totalizer, negative totalizer.

Data storage format: 1=07-04-10,14:16:33

2=+3.845778E+01m³/h

3=+1.451074E+00m/s

4=-0000010E+0m³

5=+0000002E+0m³

6=-0000012E+0m³

7=+7.1429E-01KJ/s

8=+3.9721E+03KJ

9=+4.573242E+01

10=+4.338866E+01

File system format: FAT16.

File type: plain text file (.TXT).

File number: maximum 512pcs.

File name format: yy-mm-dd (yy - year, mm - month, dd - date).

It can save 120 bytes of data each time. If it is set to save once in per 5 seconds, the capacity of storing file in 24 hours is $120 \times 3600 / 5 \times 24 = 2073600 \text{ byte} \approx 2.1 \text{ Mbyte}$, therefore, 1Gbyte SD card can store for days: $1024 / 2.1 = 487.6 \approx 487$ days. When the capacity of the SD card is full, the new data will override the earliest files automatically.

4.12.2 Install or Remove the SD Card while the Meter is Powered On

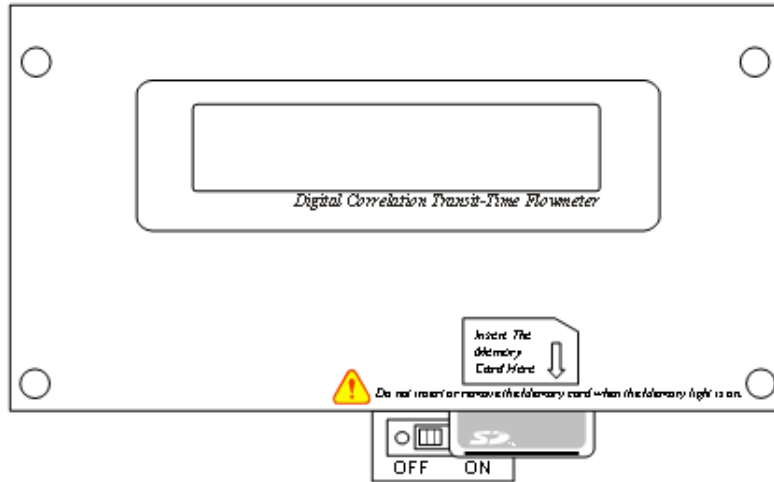

If the operator desires to insert or remove the SD card with power on, the following operation is to be used:

It is shown as the picture above, move the switch to the "OFF" position. This switch activates the Memory Logging ONLY; it DOES NOT SECURE POWER TO THE FLOWMETER. It is then safe to remove or install the SD Card. Once reinstalled, move the switch to the "ON" position, now the SD card can continue to log data.



Attention:

Do not remove the SD card from the reader while actively working with the data. Data should be saved and stored in a separate location on the PC, and then processed from that file location. Processing the data directly from the SD card file location on the PC could result in losing or destroying data if the SD card is removed while still being processed.

4.12.3 Reading the SD Data Internally with the Instrument Powered On

Open the cover of the meter; connect the flowmeter to a PC via RS232. The operator can read and work with the data in the SD card with the "Converter" software provided with the flowmeter. See as below:

1. Connect to the flowmeter.

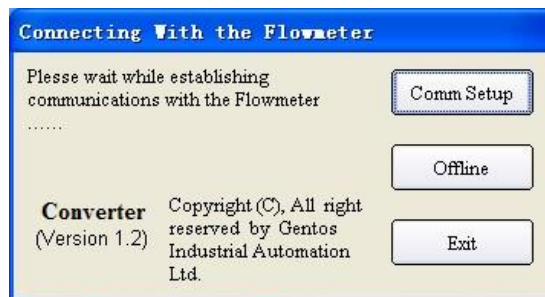

Click on "Comm Setup", Set up communications port (Generally COM1) and baud rate (19200 bps), switch the flowmeter on :



2. After connecting to the flowmeter, Show as below (If not connected to flow meter, you can click on "Offline" button interface into the document conversion):

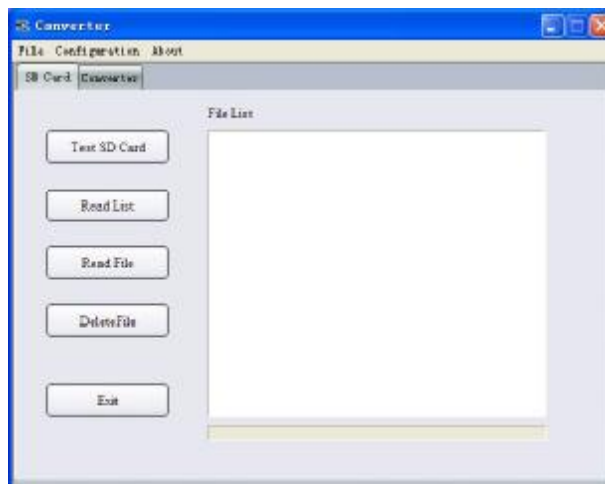

- 1) Choose "Test SD card", if the LED is lit and there will be a message "The SD card is OK" displayed to show that SD card is working.
- 2) Click on "Read list" to return to the SD card catalog of all the documents.
- 3) Use the left mouse button to select a file in the returned directory, then click on "Read File", there will be a reading of the progress of the document.



After the reading, a pop up display will show "The File has been read" and stored in the Converter.exe the root directory. And check the format of the file contents is normal or not.

- 4) Use the left mouse button to select a file (070603.TXT) in the returned directory, then click on "Delete File", then confirm the deletion. If the file is successfully deleted, a pop up display will show "The File has been deleted". If the selected file is current file, NO DELETION will be displayed.



- 3. Click the "configuration" drop-down menu, select "File type", show as below:

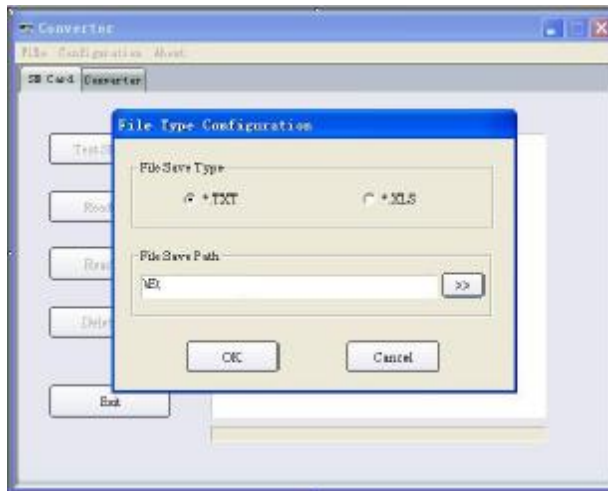

You can select the output directory format and path.

- 4. File converter tool (If not connected to flow meter, you can click on "Offline" button interface into the document conversion).

Press "Converter" button and then convert the SD card data format from ".TXT" to ".XLS", the interface is as follows:

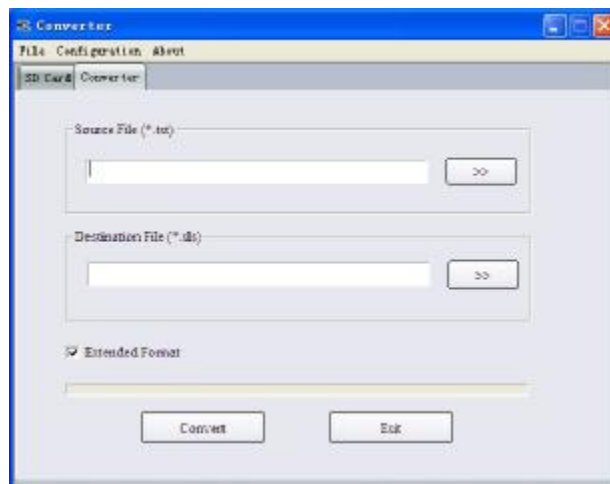

Select the file to be converted in "Source File (*.txt)", enter the directory path and the filename in "Destination File (*.xls)", then press "Convert". If "OK!" is displayed, the conversion is completed.

4.12.4 Reading the SD Data Externally

Remove the SD card from the flowmeter. The operator may then use a PC card reader to read the data on the card. Use "Converter.exe" software to convert the format when needed.



Attention:

With respect to that of storage card, the capacity of the flowmeter is too small. When some commands is executed relatively slowly and restricted, reading the SD data externally can be recommended.

4.13 ESN

We provide the flowmeter with a unique electronic serial number to identify each flowmeter for the convenience of the manufacturer and customers. The ESN, instrument types and versions are able to view in Window M61.



Attention

Other operating Refer to "5.2 Window Display Explanations".

5. Windows Display Explanations

5.1 Windows Display Codes

Flow Totalizer Display					
00	Flow Rate / Net Totalizer	24	Transducer Mounting Method	48	Sectional Correction
01	Flow Rate / Velocity	25	Transducer Mounting Spacing	49	Segmented Correction
02	Flow Rate / POS Totalizer	26	Parameter Setups	50	SD Card Data Collection Time Interval Settings
03	Flow Rate / NEG Totalizer	27	Cross-sectional Area	51	Energy Record ON/OFF
04	Date Time / Flow Rate	28	Holding with Poor Sig	Input and output setup	
05	Instantaneous Heat Capacity / Totalizer Heat Capacity	29	Empty Pipe Setup	52	Analog Input AI1
06	Instantaneous Cool Capacity/ Totalizer Cool Capacity	Flow Units Options		53	Analog Input AI2
07	Inlet Water Temp/ Outlet Water Temp / Delta Temp.	30	Metric system Units	54	Analog Input AI3
08	System Error Codes	31	Flow Rate Units Options	55	CL Output Mode Options
09	Net Flow Today	32	Totalizer Flow Units Options	56	CL 4mA Output Value
Initial Parameter setup		33	Totalizer Multiplier Options	57	CL 20mA Output Value
10	Pipe Outer Perimeter	35	POS Totalizer ON/OFF	58	CL Check Verification
11	Pipe Outer Diameter	36	NEG Totalizer ON/OFF	59	CL Current Output
12	Pipe Wall Thickness	37	Totalizer Reset	60	Date and Time Settings
13	Pipe Inner Diameter	38	Manual Totalizer	61	ESN
14	Pipe Material	Setup Options		62	Serial Port Parameter
15	Pipe Sound Velocity	40	Damping	63	AI1 Value Range
16	Liner Material	41	Low Flow Cutoff Value	64	AI2 Value Range
17	Liner Sound Velocity	42	Set Static Zero	65	AI3 Value Range
18	Liner Thickness	43	Reset Zero	67	FO Frequency Range
20	Fluid Type	44	Manual Zero Point	68	Low FO Flow Rate
21	Fluid Sound Velocity	45	Scale Factor	69	High FO Flow Rate
22	Fluid Viscosity	46	Network Identifying Address Code	70	LCD Backlit Options
23	Transducer Type	47	System Lock	72	Working Timer
				73	Alarm #1 Low Value

74	Alarm #1 High Value	88	Energy Totalizer Multiplier	Tom/Tos	Menu 91
75	Alarm #2 Low Value	89	Reset Energy Totalizer	Diag.	Menu 08
76	Alarm #2 High Value	Diagnoses			
77	Beeper Setup	90	Signal Strength and Quality	+0	Last Power Off Time and Flow Rate
78	OCT Output Setup	91	TOM / TOS*100	+1	Total Working Hours
79	Relay Output Setup	92	Fluid Sound Velocity	+2	Last Power Off Time
80	Flow Batch CTRL	93	Total Time and Delta Time	+3	Last Flow Rate
81	Flow Batch Controller	94	Reynolds Number and Factor	+4	Total ON/OFF Times
82	Date Totalizer	97	Transducer Spacing Automatic Correction Options	+6	Fluid Sound Velocity changing Range
83	Automatic Flow Correction	98	Transducer Mounting Position Options	-0	Hardware Adjusting Entry
Energy Calculation Methods		99	Temperature Units Options	-1	Temperature Calibration
84	Energy Units Options	Shortcut Buttons			
85	Specific Heat Select Options	Rate	Menu 02	-2	AI Calibration
86	Delta Temperature Sensitivity Settings	Velocity	Menu 01		
87	Energy Totalizer ON/OFF	Signal	Menu 90		
		Totalizer	Menu 00		

NOTE: The other menu features are retained by manufacturers.

5.2 Display Explanations



Flow Rate / Net Totalizer

Display flow rate and net totalizer.

If the net totalizer has been turned off (refer to M34), the net totalizer value displayed is the total prior to its turn off.

Flow 0.1154m³/h *R
NET 0x1m³



Flow Rate / Velocity

Display flow rate and velocity.

Flow 0.1129m³/h *R
Vel 1.0415m/s



Flow Rate / Positive Totalizer

Display flow rate and positive totalizer.

Select the positive totalizer units in Window M31.

If the positive totalizer has been turned off (refer to M35), the positive totalizer value displayed is the total prior to its turn off.

Flow 0.1129m³/h *R
POS 0x1m³



Flow Rate / Negative Totalizer

Display flow rate and negative totalizer.

Select the negative totalizer value in Window M31.

If the negative totalizer has been turned off (refer to M36), the value displayed is the total prior to turn off.

Flow 0.1120m³/h *R
NEG 0x1m³



Date Time / Flow Rate

Display the current date time and flow rate.

The time setting method is found in Window M60.

03-04-03 15:49:40 *R
Flow 0.1116 m³/h



Heat Capacity / Totalizer Heat Capacity

Display Instantaneous Heat Capacity and Totalizer Heat Capacity.

Net Energy Totalizer: E.T; Instantaneous Energy: EFR.

Note : when the instrument is named energy meter:

Heat Capacity: "[P]", Cool Capacity: "[N]".

EFR 0.0000 GJ/h*R
EPT 0X1 GJ



Cool Capacity / Totalizer Cool Capacity

Display Instantaneous Cool Capacity and Totalizer Cool Capacity.

EFR 0.0000 GJ/h*R
ENT OX1 GJ



Inlet Water Temp / Outlet Water Temp / Delta Temp

Display Inlet Water Temperature, Outlet Water Temperature and Delta Temperature.

In-Out-Delta C
6.21 8.21 -2.00



System Error Codes

Display the working condition and the system error codes. More than one error code can occur at the same time.

The explanations of error codes and detailed resolution methods can be found in "Error Diagnoses".

*R -----
System Normal



Net Flow Today

Display net total flow today.

Net Flow Today M09
0.458748 m3



Pipe Outer Perimeter

Enter the pipe outer perimeter. If the diameter of the pipe is known, enter it in window M11.

Pipe Outer Perimeter
157 mm



Pipe Outer Diameter

Enter the pipe outer diameter; the pipe outer diameter must range from 10mm to 6000mm.

Note: Enter Either pipe outer diameter or pipe outer perimeter.

Pipe Outer Diameter
50 mm



Pipe Wall Thickness

Enter the pipe wall thickness. If the pipe inner diameter is already known, skip this window and enter it in Window M13.

Pipe Wall Thickness
4 mm



Pipe Inner Diameter

Enter the pipe inside diameter. If the pipe outer diameter and pipe wall thickness has been entered, press to skip this window.

Note: Enter either pipe wall thickness or pipe inner diameter.



Pipe Material

Enter pipe material. The following options are available (by , buttons or numerical keys):

0. Carbon Steel	5. PVC
1. Stainless Steel	6. Asbestos
2. Cast Iron	7. Aluminum
3. Ductile Iron	8. Fiber Glass-Epoxy
4. Copper	9. Other

Refer to item 9 "Other"; it is possible to enter other materials, which are not included in previous eight items. Once item 9 is selected, the relevant pipe sound velocity must be entered in Window M15.



Pipe Sound Velocity

Enter pipe sound velocity. This function is only used when item 9 "Other" is selected in Window M14. Otherwise, this window cannot be viewed.



Select the Liner Material

The following options are available:

0. None ,No Liner	6. Polystyrene
1. Tar Epoxy	7. Polyester
2. Rubber	8. Polyethylene
3. Mortar	9. Ebonite
4. Polypropylene	10. Teflon
5. Polystryol	11. Other

Pipe Inner Diameter
52 mm

Pipe Material [14
0. Carbon Steel

Pipe Sound Velocity
2800 m/s

Liner Material [16
0. None, No Liner

Item 11 "Other" is available to enter other materials that are not included in previous ten items. Once the "Other" is selected, the relevant liner sound velocity must be entered in Window M17.



Liner Sound Velocity

Enter liner sound velocity. This function is only used when Item 11 "Other" is selected in M16.

Liner Sound Velocity
2270 m/s



Liner Thickness

Enter liner thickness. It only can be visited when a definite liner is selected in Window M16.

Liner Thickness [18
10 mm



Select Fluid Type

The following options are available:

0. Water	8. Other
1. Sea Water	9. Diesel Oil
2. Kerosene	10. Castor Oil
3. Gasoline	11. Peanut Oil
4. Fuel Oil	12. Gasoline #90
5. Crude Oil	13. Gasoline #93
6. Propane (-45°C)	14. Alcohol
7. Butane (0°C)	15. Water (125°C)

Fluid Type [20
0. Water

"Other" refers to any fluid. The relevant sound velocity must be entered in Window M21.



Fluid Sound Velocity

Enter the fluid sound velocity. It can only be used when item "Other" is selected in Window M20, i.e. it is unnecessary to enter all the fluids listed in Window M20.

Fluid Sound Velocity
1482.3 m/s



Fluid Viscosity

Enter fluid's kinematics viscosity. It only can be used when item "Other" is selected in Window M20, i.e. it is unnecessary to enter all the fluids that listed in Window M20.

Fluid Viscosity [22
1.0038 cST



Select Transducer type

The following transducer types are available:

- 0. Standard
- 1. Plug in Type B45: (W210 type insertion transducer).
- 2. Plug in Type W110
- 3. Plug in Type WH101

Transducer Type [23
0. Standard



Note:

The S, W, WH type sensors are all standard type.



Transducer Mounting Methods

Three mounting methods are available:

- 0. V (sound wave bounces 2 times)
- 1. Z (sound wave bounces once. The most commonly use method)
- 2. N (small pipe, sound wave bounces 3 times.)

Transducer Mounting
0. V



Transducer Mounting Spacing (this value is calculated by the flowmeter)

The operator must mount the transducer according to the transducer spacing displayed (ensure that the transducer spacing is measured precisely during installation). The system will display the data automatically after the pipe parameter had been entered.

Transducer Spacing
159.86 mm



Initial Parameter Setups and Save

Load and save the parameters. 18 different sets of setup conditions/groups are available to load and save by three methods (i.e.you can load and save 18 different applications):

- 0. Entry to Save
- 1. Entry to Load
- 2. To Browse

Parameter Setups
Entry to SAVE

Select "Entry to Save", press **Enter**. An ID code and the original parameters are displayed in the window. Press

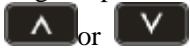

to move the ID code, then press the

Enter key again to save the current parameter in the current ID room.

When selecting "Entry to Load", press ENT, and the system will read and calculate the parameters automatically and display the transducer mounting spacing in Window M25.



Cross-Sectional Area

Display the cross-sectional area inside the pipe.

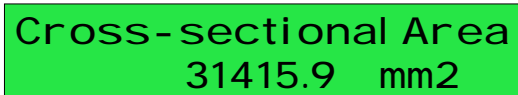

Holding with Poor Sig

Select "Yes" to hold last good flow signal displayed if the flowmeter experiences a poor signal condition. This function will allow continued data calculation without interruption.

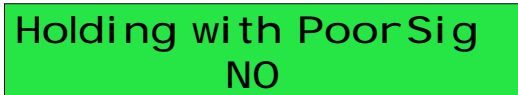

Empty Pipe Setup

This parameter is used to overcome the possible problems that usually show up when the pipe being measured is empty. Since signals can be transmitted through the pipe wall, the flow meter may still read a flow while measuring an empty pipe. To prevent this from happening, you can specify a value. When the signal quality falls below this value, the measurement stops automatically. If the flow meter is already able to stop measuring when the pipe is empty, a value in the range of 30 to 40 should also be entered in this window to ensure no measurement when the pipe is empty.



It should be understood that the instrument is NOT designed to function correctly on an empty pipe.



Metric System Units

Select the measurement unit as follows:

- 0. Metric
- 1. English

Factory default is metric.





Flow Rate Units Options

The following flow rate units are available:

- 0. Cubic Meters (m³)
- 1. Liters (l)
- 2. USA Gallons (GAL)
- 3. Imperial Gallons (Imp gal)
- 4. Million Gallons (mg)
- 5. Cubic Feet (cf)
- 6. USA Barrels (US bbl)
- 7. Imperial Barrels (Imp bbl)
- 8. Oil Barrels (Oil bbl)

The following time units are available:

- /Day /Hour
- /Min /Sec

Factory default is Cubic Meters/hour.

**Flow Rate Units [31
m3/h**



Totalizer Units Options

Select totalizer units. The available unit options are as same as those found in Window M31. The user can select units as their required. Factory default is Cubic Meters.

**Totalizer Units [32
Cubic Meter (m3)**



Totalizer Multiplier Options

The totalizer multiplier acts as the function to increase the totalizer indicating range. Meanwhile, the totalizer multiplier can be applied to the positive totalizer, negative totalizer and net totalizer at the same time. The following options are available:

**Totalizer Multiplier
0. x0.001(1E-3)**

0. x 0.001 (1E-3)	1. x 0.01
2. x 0.1	3. x 1
4. x 10	5. x 100
6. x 1000	7. x 10000(1E+4)

Factory default factor is x1.



POS Totalizer ON/OFF

On/off positive totalizer. "ON" indicates the flowmeter starts to totalize the value. When it is turned off, the positive totalizer displays in Window M02. Factory default is "ON".

**POS Totalizer [35
ON**



NEG Totalizer ON/OFF

ON/OFF negative totalizer. "ON" indicates the totalizer is turned on. When it is turned off, the negative totalizer displays in Window M03.

Factory default is "ON".

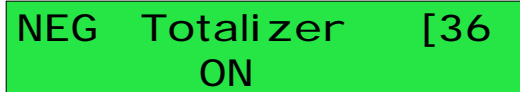

Totalizer Reset

Totalizer reset; all parameters are reset. Press **Enter**; move **^** or **v** arrow to select "YES" or "NO". After "YES" is selected, the following options are available:



None, All, NET Totalizer, POS Totalizer, NEG Totalizer, Reset.

If the user wants to delete all the already set parameters and return to the factory default, select the "Reset" option in this window. And then the flowmeter will return to the factory default automatically.



Attention

This operation will delete the entire user's data and reset as the factory default. Please consider carefully before taking this operation.



Manual Totalizer

The manual totalizer is a separate totalizer. Press **Enter** to start, and press **Enter** to stop it. It is used for flow measurement and calculation.



Damping Factor

The damping factor ranges from 0 ~ 999 seconds. 0 indicates no damping; 999 indicates the maximum damping.



The damping function will stabilize the flow display. Its principle is the same as that in a single-section RC filter. The damping factor value corresponds to the circuit time constant. Usually a damping factor of 3 to 10 is recommended in applications.



Low Flow Cutoff Value

Low Flow Cut off is used to make the system display as "0" value at lower and smaller flows to avoid any invalid totalizing. For example, if the cutoff value is set as 0.03, system will take all the measured flow velocity values from - 0.03 to + 0.03 as "0". Generally, 0.03 is recommended in most applications.

Low Flow Cutoff Val.
0.01 m/s



Set Static Zero

When fluid is in the static state, the displayed value is called "Zero Point". When "Zero Point" is not at zero in the flowmeter, the difference is going to be added into the actual flow values and measurement differences will occur in the flowmeter.

Set Zero [42]
Press ENT to go

Set zero must be carried out after the transducers are installed and the flow inside the pipe is in the absolute static state (no liquid movement in the pipe). Thus, the "Zero Point" resulting from different pipe mounting locations and parameters can be eliminated. The measuring accuracy at low flow is enhanced by doing this and flow offset is eliminated.

Press , wait for the processing instructions at the bottom right corner to reach 0.

Performing Set zero with existing flow may cause the flow to be displayed as "0". If so, it can be recovered via Window M43.



Reset Zero

Select "YES"; reset "Zero Point" which was set by the user.

Reset Zero [43]
NO



Manual Zero Point

This method is not commonly used. It is only suitable for experienced operators to set zero under conditions when it is not preferable to use other methods. Enter the value manually to add to the measured value to obtain the actual value. For example:

Manual Zero Point [44]
0 m3/h

Actual measured value = 250 m³/H

Value Deviation = -10 m³/H

Flowmeter Display = 240 m³/H

Normally, set the value as "0".



Scale Factor

The scale factor is used to modify the measurement results. The user can enter a numerical value (other than "1") according to the actual calibration results.



Network IDN

Input system identifying code, these numbers can be selected from 0 ~ 255 except that 13 (0DH ENTER), 10 (0AH Newline), 42 (2AH*) and 38 (26H&) are reserved. System IDN is used to identify the flowmeter to a network.



System Lock

Lock the instrument. Once the system is locked, any modification to the system is prohibited, but the parameter is readable. Entering your designated password correctly can be the only way to "Unlock". The password is composed of 6 numbers. (please contact the representative or manufacturer as soon as possible when the password is lost.)



Sectional Correction

ON: Open the Sectional Correction Function;
OFF: Close the Sectional Correction Function (optional)



Segmented Correction

You need input the password "115800", then press **Enter** key to expand. Expand only in the current period, automatically shut down when the power is cut off. You can set 16 groups correction coefficient for sectionally correcting measurement results. The user can input the actual scale factor, referring to the calibration results.



SD Card Data Collection Time Interval settings

Input the data collection time interval in this menu. Time is in seconds. The interval can be selected in the range of 1 ~ 60 seconds. Press **Enter**, the display shows ">" on the second line, input the required data



collection interval, and then press **Enter** again. The data collection interval is set. The factory default is 5 seconds.



Energy Record ON / OFF

When the energy record is set as "ON", SD card can record heat data, when it is set as "OFF", SD card can not record the heat data. The factory default setting is "OFF".



Analog Input AI1

Display analog input AI1 analog value.

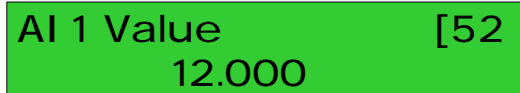

Analog Input AI2

Display analog input AI2 analog value.



Analog Input AI3

Display analog input AI3 analog value.

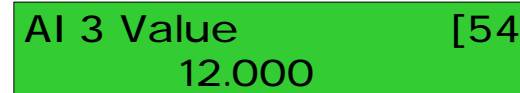

Current Loop Mode Options

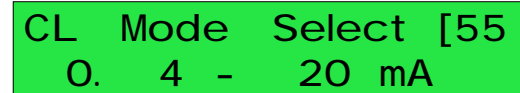

- | | | |
|----|------------------|---|
| 0. | 4-20mA | set up the output range from 4-20mA |
| 1. | 0-20mA | set up the output range from 0-20mA |
| 2. | 0-20mA via RS232 | set up to be controlled by Serial Port |
| 3. | 20-4-20mA | set up the CL output range from 20-4-20mA |
| 4. | 0-4-20mA | set up the CL output range from 0-4-20mA |
| 5. | 20-0-20mA | set up the CL output range from 20-0-20mA |
| 6. | 4-20mA vs. Vel | set up the CL output range from 4-20mA corresponding flow velocity |
| 7. | 4-20mA vs.Energy | set up the CL output range from 4-20mA corresponding heat capacity. |

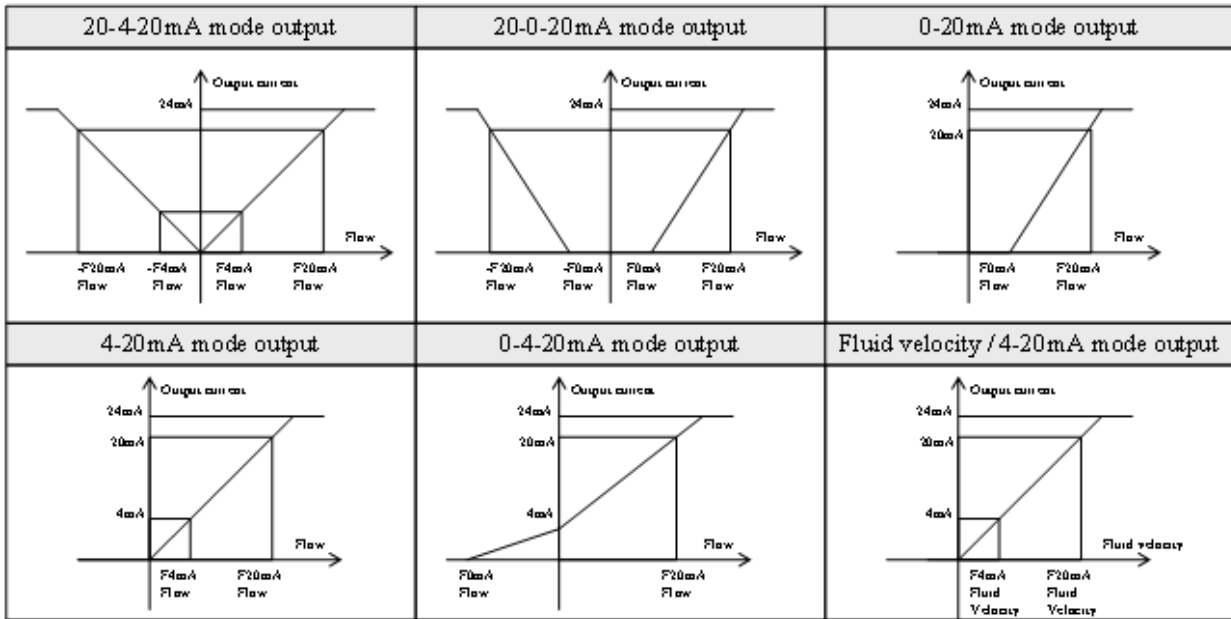

The Serial Port controls the output according to the command and parameter entered in the RS232 to output a definite current value through the current loop. The command formats are narrated in the command explanations to Serial Port controls. For example, if it is necessary to output a 6mA current through the current loop, it can be realized by setting Window M56 to the mode "0-20mA Via RS232" and giving a command as "AO6 (CR)". This function is able to make the flowmeter operate a control valve conveniently.

Other different current output characteristics are displayed in above figures. The user can select one of them according to his actual requirements.

In six graphs shown above, flow F_{0mA} or F_{4mA} indicates the value that user entered in Window M57; and flow F_{20mA} indicates the value that customer entered in Window M58. In the 4-20mA and 0-20mA modes, F_{0mA}(or F_{4mA})and F_{20mA} can be selected as a positive or negative flow value as long as the two values are not the same. As for modes 20-4-20mA and 20-0-20mA, the flowmeter ignores the positive and negative value of the actual flow; therefore, both F_{0mA} (or F_{4mA}) and F_{20mA} must be selected as positive flow values.

In mode 0-4-20mA, F_{0mA} must be select as a negative value and F_{20mA} as a positive value. Furthermore, in mode 4-20mA, the output current is indicated as velocity.



CL 4mA Output Value

Set the CL output value according to the flow value at 4mA or 0mA. (4mA or 0mA are determined by the settings in Window M56). The flow unit's options are as same as those in Window M31.

**CL 4 mA Output Value
0 m3/h**

Once "20mA vs Vel."is selected in Window M55, the unit should be set as m / s.



20mA Output Value

Set the CL output value according to the flow value at 20mA. The flow unit is the as same as that found in Window M31.

**CL 20mA Output Value
14400 m3/h**

When select "4-20mA vs Vel." the value unit in M55. The unit should be set as m / s.



CL Check Verification

Check if the current loop has been calibrated before leaving the factory. Press **Enter** move **^** or **v** separately to display 0mA, 4mA till 24mA, and at the same time, check with an ammeter to verify that CL output terminals 16 and 17 agree with the displayed values. It is necessary to re-calibrate the CL if over the permitted tolerance. For more information, refer to "Analog Outputs Calibration".

CL Checkup [58]
Press ENT WhenReady



CL Current Output

Display CL current output. The display of 10.0000mA indicates that CL current output value is 10.0000mA. If the difference between displaying value and CL output value is too large, the current loop then needs to be re-calibrated accordingly.

CL Current Output [59]
15.661 mA



Date and Time Settings

Date and time modifications are made in this window. The format for setting time setting is 24 hours. Press **Enter**, wait until ">" appears, the modification can be made.

YY-MM-DD HH:MM:SS
03-04-04 10:05:04



ESN

Display electronic serial number (ESN) of the instrument. This ESN is the only one assigned to each flowmeter ready to leave the factory. The factory uses it for files setup and for management by the user.

Ultrasonic Flowmeter
S/N=05071188



Serial Port Settings

This window is used for serial port setting. Serial port is used to communicate with other instruments. The serial port parameters setting of the instrument that applies the serial port connection must be consistence. The first selected data indicates baud rate, 9600, 19200, 38400, 56000, 57600, 115200 are available.

RS-232 Setup [62]
9600, None

The second option indicates parity bit, None (No verification).

Data length fixed to 8;

Stop bit length fixed to 1.

The factory default serial port parameter is "9600, 8,

None, 1".



AI1 Value Range

In window 63 enter temperature value which 4mA and 20mA analog input represented. In this example window "10" represent 4mA corresponding temperature value, "100" represent 20mA corresponding temperature value.

**AI 1 Value Range [63
10 - 100**



AI2 Value Range

In window 64 enter temperature value which 4mA and 20mA analog input represented. See this window "10" represent 4mA corresponding value, "100" represent 20mA corresponding value.

**AI 2 Value Range [64
10 - 100**



AI3 Value Range

In window 65 enter temperature value which 4mA and 20mA analog input represented. See this window "10" represent 4mA corresponding value, "100" represent 20mA corresponding value.

**AI 3 Value Range [65
10-100**



Set FO Frequency Range

Set up low FO Frequency and high FO frequency range. The high FO must be higher than the low FO frequency. Ranges from 1-9999Hz. Factory default is 1 ~ 1001 Hz.

**FO Frequency Range
1 - 5000**

Note: The frequency output is transmitted through OCT Serial Port; therefore the OCT must be set to the frequency output mode.(select "13. FO" in M78)



Low FO Flow Rate

Set up low FO flow rate, i.e. the corresponding flow value when output signal frequency is at the lowest

**Low FO Flow Rate [68
0 m3/h**

FO frequency. For example, when the low FO frequency is 1000Hz, low FO flow rate is 100 m³/h. When the frequency output is 1000Hz, then the low flow at this moment measured by the flowmeter is 100 m³/h.



High FO Flow Rate

Enter the high FO flow rate, i.e. the corresponding flow value when frequency output signal is at highest FO

**High FO Flow Rate [69
26550 m3/h**

frequency. For example, when the high FO frequency is 3000Hz, high FO flow rate is 1000m³/h. When the frequency output is 3000Hz, then the low flow at this moment measured by the flowmeter is 1000m³/h.



LCD Backlit Options

Select LCD backlit controls.

"Always On" indicates that the backlight remains lit constantly; "Always Off" indicates that the backlit remains off constantly. Select "Lighting For nn Sec", then enter the desired backlighting time for "n" seconds; it indicates that after pressing the button, the backlighting will keep on for "n" seconds then turn off automatically. This function saves energy. Keep the backlight can save about 30mA power.



Working Timer

Display the totalized working hours of the flowmeter since last reset. It is displayed by HH:MM: SS. If it is necessary to reset it, press **Enter**, and select "YES".



Alarm #1 Low Value

Enter the low alarm value. Both relevant alarms are turned on in Windows M78 and M79; any of the measured flow, which is lower than the low value, will activate the alarm in the OCT hardware or relay output signal.



Alarm #1 High Value

Enter the high alarm value. Both relevant alarms are turned on in Windows M78 and M79; any of the measured flow, which is higher than the high value, will activate the alarm in the OCT hardware or relay output signal.



Alarm #2 Low Value

Enter the alarm low value. Both relevant alarms are turned on in Windows M78 and M79; any measured flow, which is lower than the low value, will activate the alarm in the OCT hardware or relay output signal.



Alarm #2 High Value

Enter the alarm high value. Both relevant alarms are turned on in Windows M78 and M79; any of the measured flow, which is higher than the high value, will activate the alarm in the OCT hardware or relay output signal.

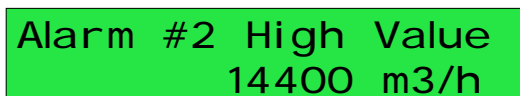
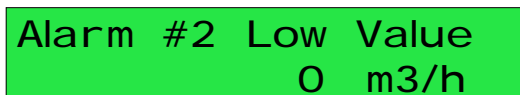
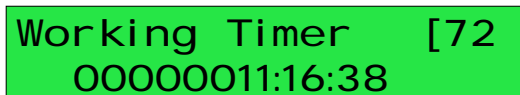



Beeper Setup

Set up the beeper on-off state.

0. No Signal	1. Poor Signal
2. Not Ready (No*R)	3. Reverse Flow
4. AO Over 100%	5. FO Over 120%
6. Alarm #1	7. Alarm #2
8. Batch Control	9. POS Int Pulse
10. NEG Int Pulse	11. NET Int Pulse
12. Energy Pulse	13. ON/OFF viaRS232
14. Fluid changed	15. Key Stroking ON
16. Not Using	

BEEPER Setup [77]
0. ON



OCT Output Setup

The following signal options are available:

0. No Signal	1. Poor Signal
2. Not Ready (No*R)	3. Reverse Flow
4. AO Over 100%	5. FO Over 120%
6. Alarm #1	7. Alarm #2
8. Batch Control	9. POS Int Pulse
10. NEG Int Pulse	11. NET Int Pulse
12. Energy Pulse	13. FO
14. FO via RS-232C	15. ON/OFF viaRS232
16. Fluid changed	17. Not Using

OCT Output Setup [78]
16. Fluid changed



Relay Output Setup

The relay is single-pole and constant-on for external instrument controls. The following options are available:

0. No Signal	1. Poor Signal
2. Not Ready (No*R)	3. Reverse Flow
4. AO Over 100%	5. FO Over 120%
6. Alarm #1	7. Alarm #2
8. Batch Control	9. POS Int Pulse
10. NEG Int Pulse	11. NET Int Pulse
12. Energy Pulse	13. ON/OFF viaRS232
14. Fluid changed	15. Key Stroking ON
16. Not Using	

RELAY Output Setup
8. Batch Control



Flow Batch CTRL

Set the input trigger for the batch control function on the flow meter. The following options are available:

0. Key Input	1. AI1 Up Edge
2. AI2 Up Edge	3. Via RS232



Flow Batch Controller

The internal batch controller in the flowmeter is able to control the input signals through keypad or analog input Serial Port. Output signals can be transmitted through OCT or relay.

The flow batch value can be modified in this window. The screen will enter the batch control display as soon as the modification completed.

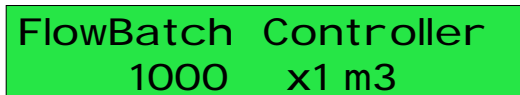

Date Totalizer

The following options are available:

- 0. Day
- 1. Month
- 2. Year

In this window, it is possible to review the historical flow data totalizer for any day for the last 64 days, any month for last 64 months and any year for last 5 years.

Press **Enter**, use the **^** or **v** to review totalizer in days, months and years.

For example, to display the flow total for July 18, 2000, the display "-----" at the upper right corner of the screen indicates that it was working properly the whole day. On the contrary, if "G" is displayed, it indicates that the instrument gain was adjusted at least once. Probably it was offline once on that day.

Left upper corner: "00-63" indicates the serial numbers; In the middle: "03-04-05" indicates the date; Upper right corner: "-----" indicates the system was normal during that time period. If other characters displayed, please refer to the "Error Code and Resolutions".

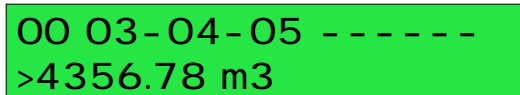



Automatic Flow Correction

With the function of automatic flow correction, the flow lost in an offline session can be estimated and automatically adjusted. The estimate is based on the average value, which is obtained from flow rate before going offline and flow measured after going online the next time, multiplied times the time period that the meter was offline. Select "NO" to use this function, select "OFF" to cancel this function.



Energy Units Options

Select Energy Units. The factory default unit is GJ. The following options are available:

0. Giga Joule (GJ)	1. Kilocalorie (Kc)
2. MBtu	3. KJ
4. Btu	5. KWh
6. MWh	7. TH

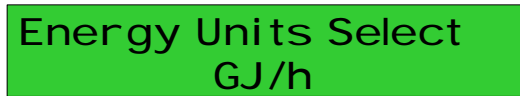

The following units of time are available:
 /day (per day); /hour (per hour); /min (per minute);
 /sec (per second). The factory default unit is /hour.



Specific Heat Select

Select the following 2 kinds of specific heat value:

Press Enter, choose 0.RTD 1.AI

Then, press Enter, choose 0.CJ128 SHC 1.USER SHC

The Menu 85 factory default set is 0.RTD>0.CJ128 SHC, When the user need to change the enthalpy, 1.USER SHC can be selected, press"enter", the user can input the enthalpy value.



Temperature sensitivity and user SHC

When the delta temperature is less than the sensitivity set,, energy will not be accumulated. Set the adjustable temperature range of 0°C to 10°C.

The factory default setting is 0.2°C

When the user specific heat is setting, energy is accumulated according to the user specific heat value. The setting range is from 1 to 99999 KJ/m3 C.

The factory default is 4186.8KJ/m3C.

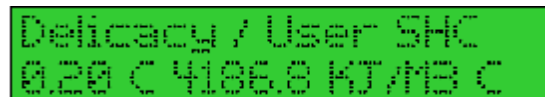



Energy Totalizer Switch

Select "ON" represent to open Energy Totalizer;
 Select "OFF" represent to close Energy Totalizer.



Energy Multiplier

Select Energy Multiplier range: $10^{-3} \sim 10^4$ (E-3 ~ E4)

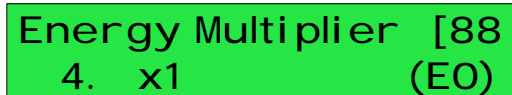

Reset Energy Totalizer

Select "YES" to reset Energy Totalizer value.

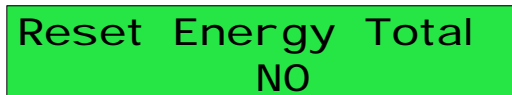

Signal Strength and Signal Quality

Display the measured signal strength and signal quality Q value upstream and downstream.

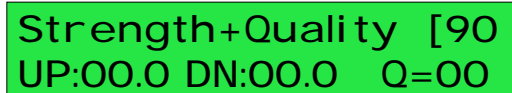

Signal strength is indicated from 00.0 ~ 99.9. A reading of 00.0 indicates no signal detected, while 99.9 indicates maximum signal strength. Normally the signal strength should be ≥ 60.0 .

Signal quality Q is indicated by 00 ~ 99. Therefore, 00 indicates the poorest signal while 99 indicates the best signal. Normally, signal quality Q value should be better than 50.



TOM/TOS*100

Display the ratio between the actual measured transmit time and the calculated transmit time according to customer's requirement. Normally the ratio should be $100 \pm 3\%$. If the difference is too large, the user should check that the parameters are entered correctly, especially the sound velocity of the fluid and the installation of the transducers.



This data is of no use before the system is ready.



Fluid Sound Velocity

Display the measured fluid sound velocity. Normally this value should be approximately equal to the entered value in Window M21. If the difference is too large, it probably results from an incorrect value entered in Window M21 or improper installation of the transducers.

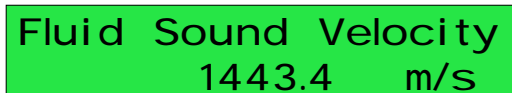



Total Time and Delta Time

Display the measured ultrasonic average time (unit: uS) and delta time of the upstream and downstream (unit: nS) time. The velocity calculation in the flowmeter is based on the two readings. The delta time is the best indication that the instrument is running steadily. Normally the fluctuation in the ratio of the delta time should be lower than 20%. If it is not, it is necessary to check if the transducers are installed properly or if the parameters have been entered correctly.

Totl Time, Delta Time
8.9149uS, -171.09nS



Reynolds Number and Factor

Display the Reynolds number that is calculated by the flowmeter and the factor that is set currently by the flowmeter. Normally this scaling factor is the average of the line and surface velocity factor inside the pipe.

Reynolds Number [94]
0.0000 1.0000



Installation spacing correction Options

The following options are available:

- 0.OFF Turn off Installation spacing correction
- 1.ON Turn on Installation spacing correction

Spacing Correction
0.OFF



Flow sensor setup (Transducer Mounting Position Selection)

The following options are available:

- 0. Infall
- 1. Outfall

Flow Senser Set Up
0.I nfall



Temperature Units Options—

centigrade°C Fahrenheit °F

When you choose °F, The temperature unit of Menu07 and Menu 86 will be changed to °F, the specific heat unit of Menu 86 will be changed to KJ/m3*°F. SD card will record the temperature in °F and Modbus will read RTD temperature value in °F

Temperature Unit
0. C



Power ON/OFF Time

To view the power on/off time and flow rate for the last 64 update times to obtain the offline time period and the corresponding flow rate.

Enter the window, press **Enter** to display the last update before the last 64 times of on/off time and flow rate values. "ON" on right hand indicates that time power is on; "00" on the upper left corner indicates "00-07-18 12:40:12" the date and time; flow rate is displayed in the lower right corner.



Total Working Hours

With this function, it is possible to view the total working hours since the flowmeter left the factory. The figure on the right indicates that the total working hours since the flowmeter left the factory is 1107 hours 1 minute 41 seconds.



Last Power Off Time

Display the last power off time.



Last Flow Rate

Displays the last flow rate.



Total ON/OFF Times

Display total on / off times since the flowmeter left the factory.



Fluid Sound Velocity Changing Range

The data displayed in the window is a sound velocity comparator threshold value, namely when the estimated medium sound velocity is over the value, an alarm signal can be produced. The alarm signal can be output to the relay or OCT. Through the numerical settings, the ultrasonic flowmeter can make an alarm signal as soon as the medium changing.



Hardware Adjusting Entry

ON/OFF Time [+0]
Press ENT When Ready

00-07 18 12:40:12
*ON 123.65 m3/h

Total Work Hours [+1]
00001107:01:41

Last Power Off Time
03-04-04 11:33:02

Last Flow Rate [+3]
100.43 m3/h

ON/OFF Times [+4]
40

Velocity changing
1m/s

Hardware Adjusting
Entry

Please refer to Chapter 4.6 "4-20mA Current Loop Output" for more details.



Temperature Calibration

Please refer to Chapter 11.4 "Temperature Calibration Methods" for more details.



AI Calibration

Connect the analog input to standard 20mA, input the password 115800 and enter the calibration, press

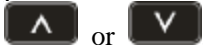

then adjust AI value to the AI range upper limit.

Adjust Temperature
Press ENT When Ready

Adjust AI [-2]
Press ENT When Ready

6. Error Diagnoses

The ultrasonic flowmeter has advanced self-diagnostics functions and displays any errors in the upper right corner of the LCD via definite codes in a date/time order. Some errors can be detected during normal operation. Undetectable errors caused by unskilled operation, incorrect settings and unsuitable measurement conditions can be displayed accordingly during work. This function helps the user detect the errors and find causes quickly; thus, problems can be solved in a timely manner according to the solutions listed in the following table.

The error codes caused by incorrect settings and the detected signal can be displayed in Window M08.

If a problem still exists, please contact the factory or the factory's local representative for assistance.

6.1 Table 1. Error Codes and Solutions (During Operation)

Codes	M08 Display	Causes	Solutions
*R	System Normal	* System normal.	
*I	Signal Not Detected	<ul style="list-style-type: none"> * Signal not detected. * Spacing is not correct between the transducers or not enough coupling compound applied to face of transducers. * Transducers installed improperly. * Scale is too thick. * New pipe liner. 	<ul style="list-style-type: none"> ** Attach transducer to the pipe and tighten it securely. Apply a plenty of coupling compound on transducer and pipe wall. * Remove any rust, scale, or loose paint from the pipe surface. Clean it with a file. * Check the initial parameter settings. * Remove the scale or change the scaled pipe section. Normally, it is possible to change a measurement location. The instrument may run properly at a new site with less scale. * Wait until liners solidified and saturated.
*G	Adjusting Gain	* Adjusting gain for normal measurement.	

6.2 Frequently Asked Questions and Answers

Question: New pipe, high quality material, and all installation requirements met: why still no signal detected ?

Answer: Check pipe parameter settings, installation method and wiring connections. Confirm if the coupling compound is applied adequately, the pipe is full of liquid, transducer spacing agrees with the screen readings and the transducers are installed in the right direction.

Question: Old pipe with heavy scale inside, no signal or poor signal detected: how can it be resolved?

Answer: Check if the pipe is full of fluid. Try the Z method for transducer installation (If the pipe is too close to a wall, or it is necessary to install the transducers on a vertical or inclined pipe with flow upwards instead of on a horizontal pipe).

Carefully select a good pipe section and fully clean it, apply a wide band of coupling compound on each transducer face (bottom) and install the transducer properly.

Slowly and slightly move each transducer with respect to each other around the installation point until the maximum signal is detected. Be careful that the new installation location is free of scale inside the pipe and that the pipe is concentric (not distorted) so that the sound waves do not bounce outside of the proposed area.

For pipe with thick scale inside or outside, try to clean the scale off, if it is accessible from the inside. (Note: Sometimes this method might not work and sound wave transmission is not possible because of the a layer of scale between the transducers and pipe inside wall).

Question: Why is the CL output abnormal?

Answer: Check to see if the desired current output mode is set in Window M55.

Check to see if the maximum and minimum current values are set properly in Windows M56 and M57.

Re-calibrate CL and verify it in Window M59.

Question: Why is the flow rate still displayed as zero while there is fluid obviously inside the pipe and a symbol of "R" displayed on the screen?

Answer: Check to see if "Set Zero" was carried out with fluid flowing inside the pipe (Refer to Window M42). If it is confirmed, recover the factory default in Window M43.

7. Product Overview

7.1 Introduction

The Model D118 Ultrasonic Flowmeter is a state-of-the-art universal transit-time flowmeter designed using ARM COMA technology and low-voltage broadband pulse transmission. While principally designed for clean liquid applications, the instrument is tolerant of liquids with the small amounts of air bubbles or suspended solids found in most industrial environments.

7.2 Features of D118

Comparing With other traditional flowmeter or ultrasonic flowmeter, it has distinctive features such as high precision, high reliability, high capability and low cost, the Flowmeter features other advantages:

1. With ARM COMA chip, low power consumption, high reliability, anti-jamming and outstanding benefits.
2. User-friendly menu designed. Parameters of pipe range, pipe material, pipe wall thickness, output signals, etc can be conveniently entered via the windows. British and Metric measurement units are available.
3. Daily, monthly and yearly totalized flow: Totalized flow for the last 64 days and months as well as for the last 5 years are may be viewed. Power on/off function allows the viewing of time and flow rate as power is switched on and off 64 times. Also, the Flowmeter has manual or automatic amendment during offline sessions.
4. With the SD Card, 512 files can be stored; the time interval can be within 1 second.
5. Parallel operation of positive, negative and net flow totalizer with scale factor and 7 digit display. Internally configured batch controller makes batch control convenient.

The flow meter ensures the higher resolution and wider measuring range by the 0.04nS high resolution, high linearity and high stability time measuring circuit and 32 bits digits processing program.

7.3 Theory of Operation

When the ultrasonic signal is transmitted through the flowing liquid, there will be a difference between the upstream and downstream transit time (travel time or time of flight), which is proportional to flow velocity, according to the formula below.

$$V = \frac{MD}{\sin 2\theta} \times \frac{\Delta T}{T_{up} \cdot T_{down}}$$

Remarks:

- V Medium Velocity
 M Ultrasonic frequency of reflection
 D Pipe Diameter
 θ The angle between the ultrasonic signal and the flow
 T_{up} Transit time in the forward direction
 T_{down} Transit time in the reverse direction

$$\Delta T = T_{up} - T_{down}$$

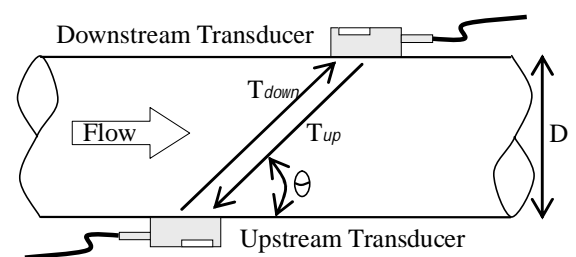

7.4 Applications

- | Water, sewage (with low particle content) and seawater;
 - | Water supply and drainage water;
 - | Power plants (nuclear power plant, thermal and hydropower plants), heat energy, boiler feed water and energy management system;
 - | Metallurgy and mining applications (cooling water and acid recovery, for example);
 - | Petroleum and chemicals;
 - | Food, beverage and pharmaceutical;
 - | Marine operation and maintenance;
 - | Energy economy supervision and water conservation management;
 - | Pulp and paper;
 - | Pipeline leak detection;
 - | Regular inspection, tracking and collection;
 - | Energy measuring and balance;
- Network monitoring systems and energy / flow computer management.

7.5 Specifications

Performance specifications	
Flow Range	±(0.03ft/s ~ 40 ft/s) ±(0.01m/s ~ 12 m/s)
Accuracy	± 0.5% of measured value.
Repeatability	0.15%.
Pipe Size	1" ~ 200" (25 mm ~ 5000 mm).
Function Specifications	
Output	Analog output: 0/4 ~ 20 mA, (max load 750 Ω); Pulse output: 0 ~ 9999 Hz, OCT (min. and max. frequency is adjustable); Relay output: max. frequency 1Hz (1A@125VAC or 2A@30VDC).
Communication Interface	RS232 & RS485.
SD Card (standard)	Max record: 512 days. Record time interval: 1 ~ 3600 s.
Power Supply	90 ~ 245 VAC, 48 ~ 63 Hz Or 10 ~ 36 VDC.
Keypad	22 light tactile keys.
Display	20 × 2 lattice alphanumeric, backlit LCD.
Temperature	Transmitter: -40°F ~ 140 °F (- 40°C ~ 60°C). Transducer: -40 °F ~ 176 °F (- 40 °C ~ 80 °C, standard).
Humidity	Up to 0 ~ 99% RH, non - condensing.
Physical specifications	
Transmitter	Die-cast aluminum, IP65.
Transducer	Encapsulated design. Standard / Maximum cable length: 30 ft / 1000 ft (9m / 305 m).
Weight	Transmitter: approximately 4.7 lb (2.15 kg). Transducer: approximately 2.0 lb (0.9 kg). (standard)

8. Appendix1 - W210 Insertion Transducer

8.1 Overview

W210 type insertion transducers can be installed into metal pipelines via an isolation ball valve (installation into pipelines of plastic or other materials may require an optional mounting seat). The maximum pipe diameter in which insertion transducers can be installed is DN2000. Fluid temperature range: +10°C ~ +80°C. Sensor cable length (9m standard) normally can be extended to as long as 100m.

Figure 1 shows a diagram of the W210 Insertion Transducer. The insertion transducer is attached to its mounting base (which is welded to the pipe section at the measurement point) via a ball valve. When the transducer is removed, pipe fluids can be contained by shutting off the ball valve. Therefore, installation and extraction of the transducer can be performed without relieving pipeline pressure. An O-ring seal and joint nut guarantee user safety while installing or operating the transducer.

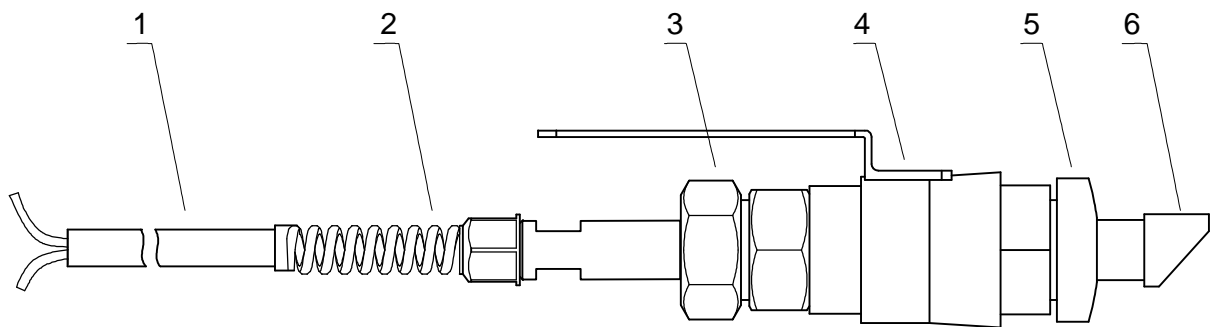

Figure 1 of Construction Drawing of W210 Insertion type Transducer

- | | | |
|--------------|---------------|---------------------|
| 1. Cable | 3. Lock - nut | 5. Mounting base |
| 2. Connector | 4. Ball valve | 6. Transducer probe |

8.2 Measurement Point Selection

To obtain the strongest signal strength and the highly accurate measurement results, it is necessary to select an appropriate measurement point before installing the transducer. For examples of measuring point selection, see the related section in the manual.

8.3 Determining Transducer Spacing & Transducer Installation

The mounting space of insertion transducer is the center-to-center hole distance between the two transducers (please refer to Menu 25). After entering the right parameter, please check the mounting space in Menu 25. (unit: mm)

Mounting method:

1. Drilling at the measuring point, the diameter of the drilling hole is 24mm. Before drilling, please make the hole center of transducer mounting base aim at the drilling hole center, and then weld it on the pipe vertically. (When the flowmeter need to be hot-tapped into the pipe under pressure without flow interruption ,please refer to the Sitalab' operation construction of DDK electric Hot-tapping or corresponding equipment.)
2. Close the ball valve and screw it tightly on the mounting base.
3. Twist off the locknut and loose the lock ring, pull the transducer into the joint nut, and then screw up the joint nut on the ball valve.
4. Open the ball valve and insert the transducer, measure the dimension from the outer surface of the pipe to the

front end surface of handspike position to meet the following formula:

$$H = 175 - d$$

In this formula:

H is Mounting height (mm);

175 is Transducer length (mm);

d is Pipe wall thickness (mm).

5. Attach the lock ring to the joint nut by fitting its pinhole in the locating pin, then tighten the screw slightly and turn the orientation handle until it points at the middle position between the two transducers and its axes matches the axes of the pipeline. Finally, tighten the locking screw and screw the locating sleeve onto the joint nut.
6. Connect the transducer cables to the corresponding upstream / downstream (upstream = red, downstream = blue) terminal ends.
7. Please refer to the following installation diagram:

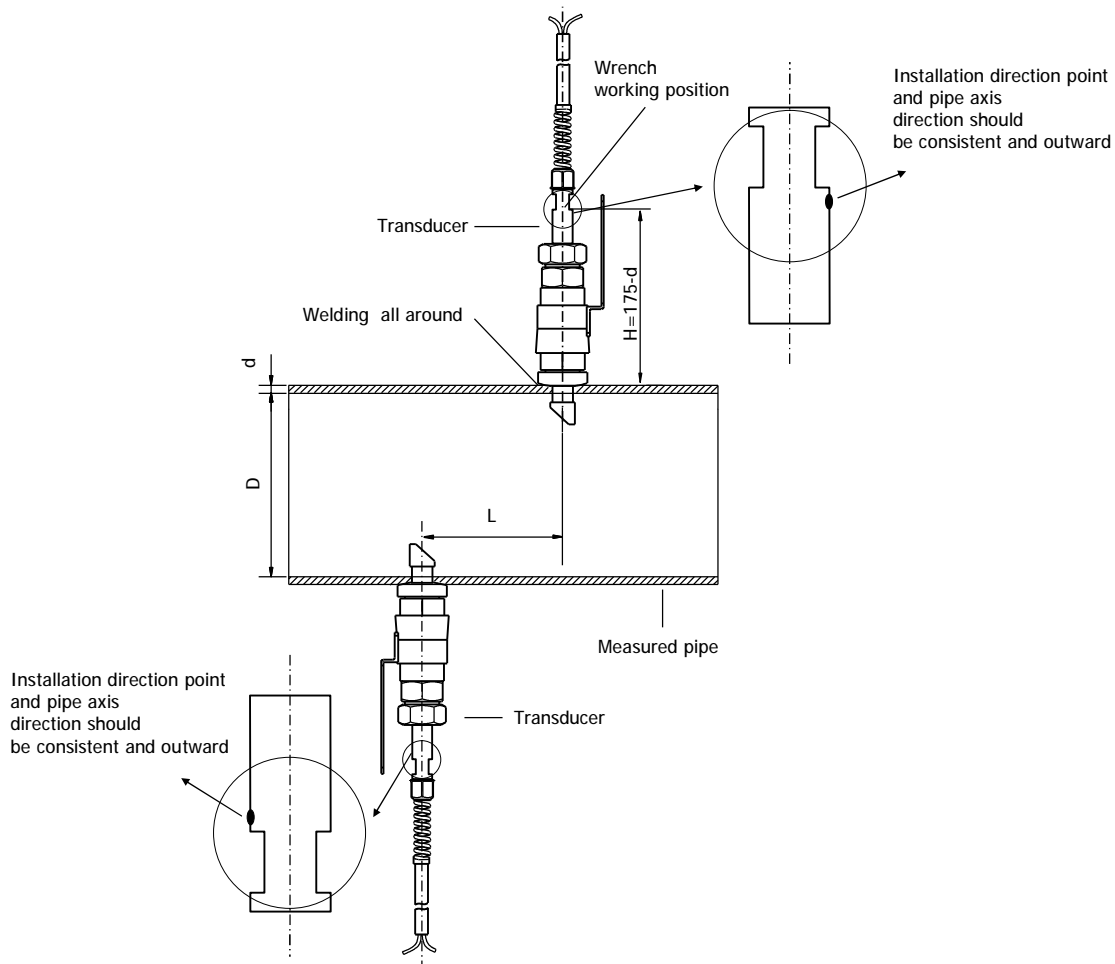

Important:

For horizontal pipelines, transducers must be fixed on the sides of the pipe (i.e. at the 3 and 9 o'clock position of the pipe) to prevent signal attenuation caused by sediment on the bottom of the pipe or air bubbles and air pockets in the top of the pipe.

8.4 Transducer Mounting Methods

W210 insertion transducer mounting method: Z method through M24, it should be installed according to the specific application condition.

8.5 Z Mounting Method

Z method is the most commonly used mounting method for insertion-type ultrasonic flowmeters, suitable for pipe diameters ranging from 50mm to 2000mm. Due to strong signal strength and high measurement accuracy, the Z method is preferable for pipe sections severely rusted or with too much scale formation on the inside wall. When installing the transducer using the Z method, be sure that the two transducers and the pipeline center axis are in the same plane, but never in the 6 or 12 o'clock positions. See below:

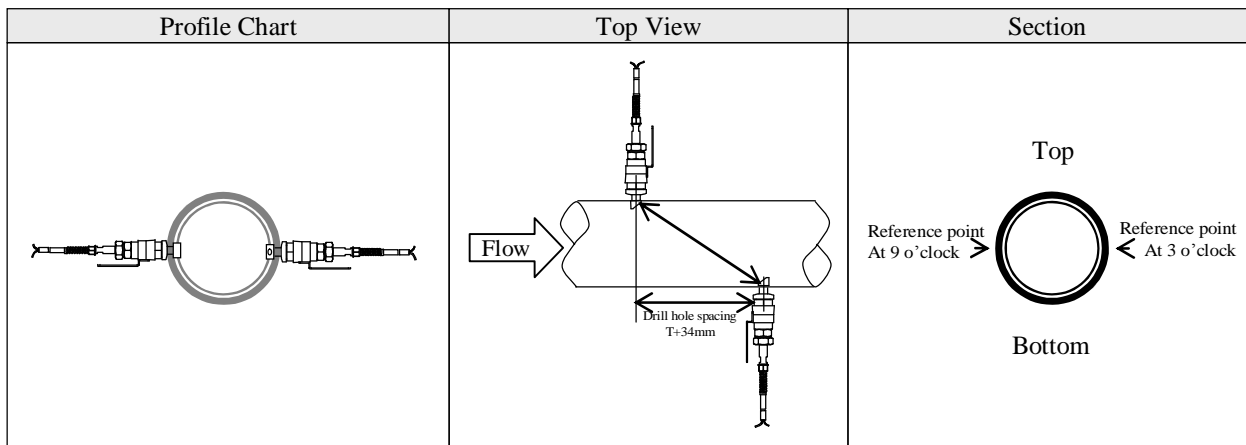

8.6 Pipe Parameter Entry Shortcuts

For example, measuring the diameter of DN200, pipe outside diameter is 219mm, pipe wall thickness is 6mm, pipe inner diameter is 207mm, measuring medium is water, and material is carbon steel, no liner, can be operated as follows:

Step1. Pipe outside diameter:

Press **Menu** **pipe dia.** **1** **1** keys to enter the window M11 and enter the pipe outside diameter, and then press the **Enter** key to confirm.

Pipe Outer Diameter
207mm

(For insertion transducer, M11 menu need to be entered the pipe inner diameter)

Step2. Pipe wall thickness

Press **Menu** **pipe dia.** **1** **pipe thck.** **2** key to enter the window M12, and enter the pipe wall thickness, and press the **Enter** key to confirm.

Pipe Wall Thickness
0.01mm

(The Wall Thickness needs to be 0.01mm for use with insertion sensors.)

Step3. Pipe Material

Press **Menu** **pipe dia.** **1** **pipe mat.** **4** keys to enter the window M14, press the **Enter** key, press **^** or **v**

Pipe Material [14]
0. Carbon Steel

key to select Pipe Material, and press the **Enter** key to confirm.

Step4. Transducers type

Press **Menu** **pipe thick** 2 **pipe mat** 3 keys to enter the window M23, press **^** or **v** key to select transducer type, and press the **Enter** key to confirm.

1. Plug — in Type B45 (W210 type insertion transducer).

TransducerType [23
1.Plug-in Type B45

Step5. Transducer mounting methods

Press **Menu** **pipe thick** 2 **trans mount** 4 keys to enter the window M24, press the **Enter** key, press **^** or **v** key to select transducer-mounting method, and press the **Enter** key to confirm.

Choose according to the pipes on site.

Transducer Mounting
1. Z

Step6. Adjust Transducer spacing

Press **Menu** **pipe thick** 2 **transer mount** 5 keys to enter the window M25, accurately install the transducer according to the displayed transducer mounting spacing and the selected mounting method (Refer to Installing the Transducers in this chapter).

Transducer Spacing
192.68mm

Step7. Display measurement result

Press **Menu** **cal** 0 **pipe dia** 1 keys to enter the window M01.

Flow 0.1129 m3/h *R
Vel 1.0415m/s

About other setups, please refer to the related information in the manual.

9. Appendix2 –W110 Insertion Transducer

9.1 Overview

W110 type insertion transducer (hereinafter referred to as for plug-in sensor) can be through ball valve installed on the carbon steel pipe (if installed on plastic pipes or other material, may need to install the choose and buy other coupling to install). The maximum pipe diameter in which insertion transducers can be installed is DN5000mm. and it can measure temperature range from -40 to +80°C. Cable standard length is 9 meters, and it can be extended to 300 meters.

See below the specific structure of the Insertion Transducer. The insertion transducer is attached to its mounting base via a ball valve. When the transducer is removed, pipe fluids can be contained by shutting off the ball valve. Therefore, installation and extraction of the transducer can be performed without relieving pipeline pressure. An O-ring seal and joint nut guarantee user safety while installing or operating the transducer.

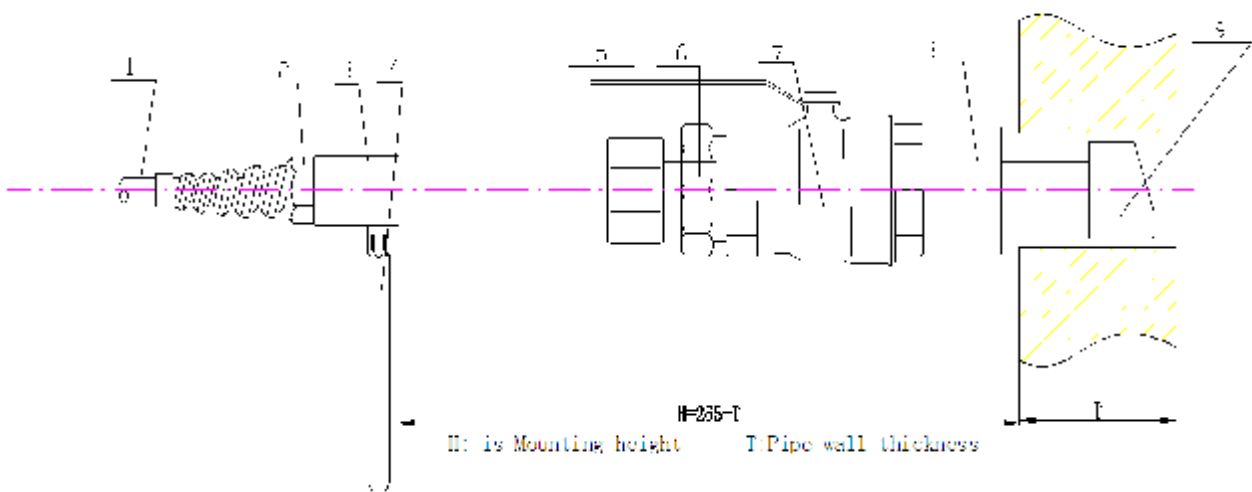

- | | | |
|----------------------|------------------------------------|----------------------|
| 1.Cable | 2.Flexed-resistance revolved piece | 3.Connector |
| 4.Orientation handle | 5.Locating sleeve | 6.Joint nut |
| 7.Ball valve | 8.Mounting base | 9.Transducer housing |

9.2 Measurement Point Selection

To obtain the strongest signal strength and the highly accurate measurement results, it is necessary to select an appropriate measurement point before installing the transducer. For examples of measuring point selection, see the related section in the manual.

9.3 Determining Transducer Spacing and Installation Method

The mounting space of insertion transducer is the center-to-center hole distance between the two transducers (please refer to Menu 25). After enter the right parameter, please check the mounting space in Menu 25. (unit: mm). Calculate the center-to-center hole distance S between the two transducers by using the formula below:

$$S=SP+34(\text{units:mm})$$

In this formula, SP is the spacing value calculated (by the flowmeter) by entering the pipe parameters such as pipe inner diameter, pipe wall thickness, etc. (Units in mm). Mounting method:

- 1.Drilling at the measuring point, the diameter of the drilling hole is 40mm. Before drilling, please make the hole center of transducer mounting base aim at the drilling hole center, and then weld the mounting base of the

transducer vertically at that position on the pipe surface. (When the flowmeter need to be hot-tapped into the pipe under pressure without flow interruption, please refer to the Sitelab’ operation construction of DDK electric Hot-tapping or corresponding equipment.)

2. Tighten the ball valve securely onto the mounting base (shut off the ball valve).
3. Unscrew the locating sleeve and loosen the lock ring, retract the transducer into the joint nut, and then tighten the joint nut onto the ball valve.
4. Open the ball valve, insert the sensor to the tube, at the same time the tube to the surface size measurement, and make sure it complies with the following formula:

$$H=265-h$$

In this formula:

H is Mounting height (mm)

265 is Transducer length (mm)

h is Pipe wall thickness (mm)

5. Attach the lock ring to the joint nut by fitting its pinhole in the locating pin, then tighten the screw slightly and turn the orientation handle until it points at the middle position between the two transducers and its axes matches the axes of the pipeline. Finally, tighten the locking screw and screw the locating sleeve onto the joint nut.
6. Connect the transducer cables to the corresponding upstream/downstream (upstream=red, downstream=blue) terminal ends.



Important

For horizontal pipelines, transducers must be fixed on the sides of the pipe (i.e. at the 3 and 9 o’clock position of the pipe) to prevent signal attenuation caused by sediment on the bottom of the pipe or air bubbles and air pockets in the top of the pipe.

9.4 Menu Setup Instructions

For example, let us you have a pipe of 168mm outer diameter and 156mm inner diameter, measuring medium is water, Pipe Material is carbon steel with no Liner, These parameters should be operated as follows:

Step1. Pipe outer diameter:

Press key to enter Window M11, and enter the pipe inner diameter, when W type setting, direct input pipe inner diameter value measurement. ,and then press key to confirm.

Pipe Outer Diameter
156 mm

Step2. Pipe wall thickness

Press key to enter Window M12, and enter the pipe wall thickness, and press key to confirm.

confirm.

Pipe Wall Thickness
0.01mm

Step3. Pipe Material

Press keys to enter Window M14, press key, press or key to select Pipe Material, and press key to

Liner Material [16
0. None, No Liner

Step 4. Fluid Type

Press key to enter Menu 20, press the

key, use the or key to select fluid type from the drop-down Menu, then press key to confirm.



Step5. Transducer Type

Press key to enter Window M23, press the key, move or key to select transducer type, and press the



Step 6. Transducer Mounting Methods

Press key to enter Menu 24, press the key, use or key to select transducer-mounting from the drop-down Menu, then press key.



Step 7. Adjust Transducer Spacing

Press key to enter Menu 25, accurately install the transducer according to the displayed transducer mounting spacing and the selected mounting method.

S=SP+34 (unit: mm)

SP for window shows the numerical 25.



9.5 Installation Method

9.5.1 Z Mounting Method

There are three kinds of insertion transducer installation method: Z Mounting Method、V Mounting Method、W Mounting Method、 Are set in the menu MENU24, want to choose according to specific application conditions.

Z method is the most commonly used mounting method for insertion-type ultrasonic flowmeters, suitable for pipe diameters ranging from 50 mm to 5000 mm. Due to strong signal strength and high measurement accuracy, the Z method is preferable for pipe sections severely rusted or with too much scale formation on the inside wall. When installing the transducer by using the Z method, be sure that the two transducers and the pipeline center axis are in the same plane, but never in the 6 or 12 o'clock positions. (See below:)

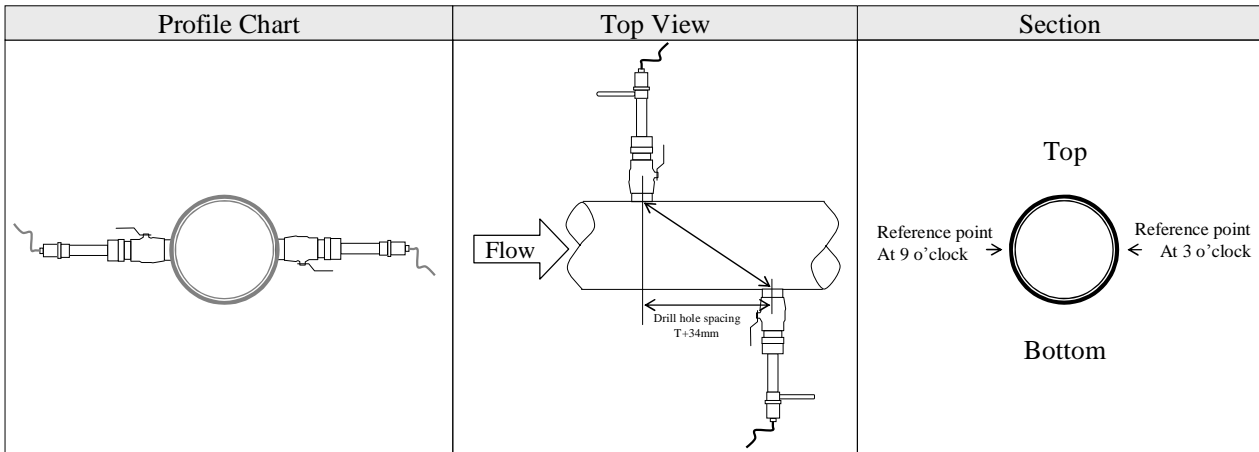

9.5.2 V Mounting Method

V method is suitable for pipe diameters ranging from 300mm to 1200mm. It is used when only one side of the pipe is available (example: the other side is against a wall) at the installation site, (See below:)

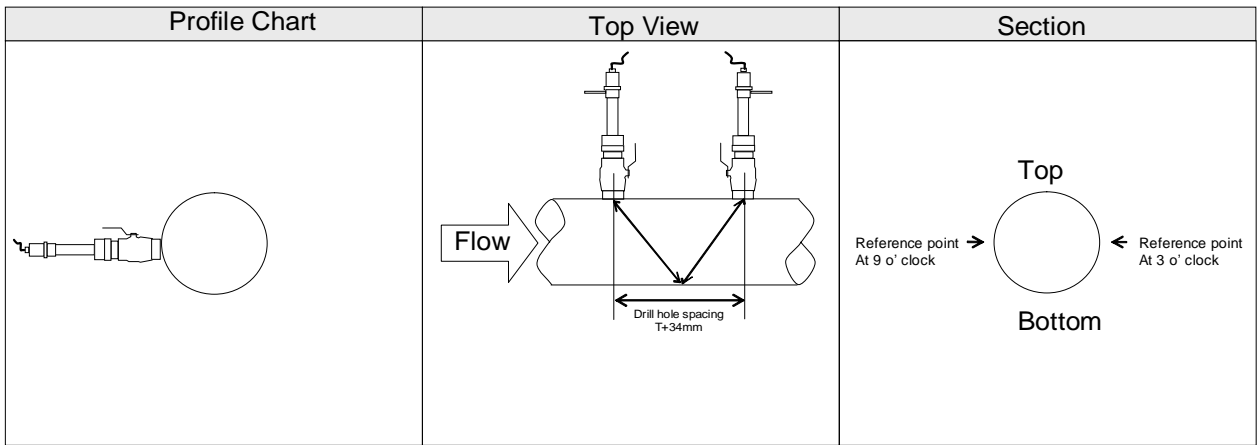

9.5.3 W Mounting Method

W method is suitable for pipe diameters ranging from 50 mm to 500 mm .This kind of installation method can prolong road and improve the measurement stability.(see below)

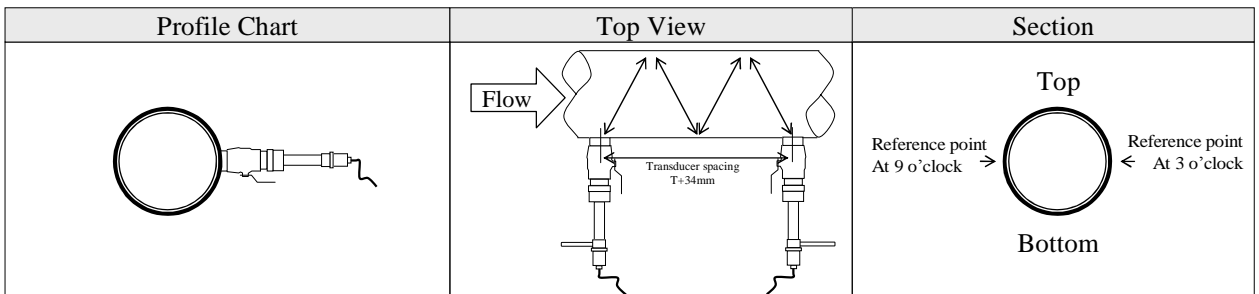

10. Appendix3 – WH Insertion Transducer

10.1 Overview

WH type insertion transducer can be installed into metal pipelines via an isolation ball valve, and it can measure fluid range from -40 to +150°C. The maximum pipe diameter in which insertion transducers can be installed is DN5000mm. The insertion transducer length is 237mm. Note that the pipe wall thickness of the pipe section should not be smaller than 24mm.

Figure 2 shows a diagram of the Insertion Transducer (Ordering option – WH). The insertion transducer is attached to its mounting base (which is welded to the pipe section at the measurement point) via a ball valve. When the transducer is removed, pipe fluids can be contained by shutting off the ball valve. Therefore, installation and extraction of the transducer can be performed without relieving pipeline pressure. An O-ring seal and joint nut guarantee user safety while installing or operating the transducer.

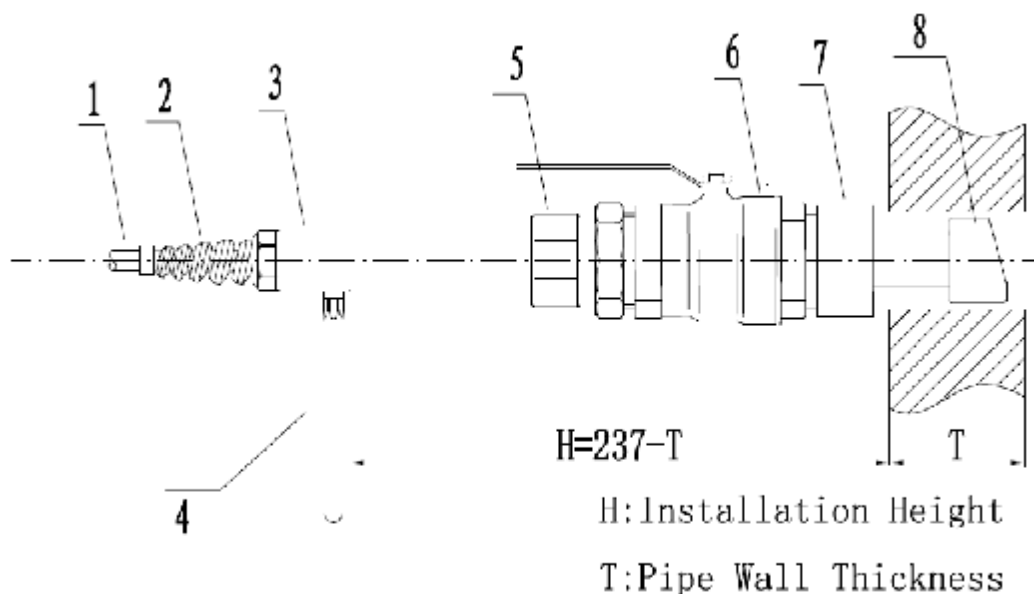

Figure 2 of Construction Drawing of WH Insertion type Transducer

- | | | |
|--------------|-----------------------|---------------------|
| 1. Cable | 4. Orientation handle | 7. Mounting base |
| 2. The locks | 5. Locating sleeve | 8. Transducer probe |
| 3. Connector | 6. Ball valve | |

10.2 Measurement Point Selection

To obtain the strongest signal strength and the highly accurate measurement results, it is necessary to select an appropriate measurement point before installing the transducer. For examples of measuring point selection, see the related section in the manual.

10.3 Determining Transducer Spacing & Transducer Installation

The mounting space of insertion transducer is the center-to-center hole distance between the two transducers (please refer to Menu 25). After enter the right parameter, please check the mounting space in Menu 25. (unit: mm). Calculate the center-to-center hole distance S between the two transducers by using the formula below:

$$S = SP+34 \text{ (Units: mm)}$$

In this formula, SP is the spacing value calculated (by the flowmeter) by entering the pipe parameters such as pipe inner diameter, pipe wall thickness, etc. (Units in mm). Mounting method:

Drilling at the measuring point, the diameter of the drilling hole is 40mm. Before drilling, please make the hole center of transducer mounting base aim at the drilling hole center, and then weld the mounting base of the transducer vertically at that position on the pipe surface. (When the flowmeter need to be hot-tapped into the pipe under pressure without flow interruption ,please refer to the Sitelab’ operation construction of DDK electric Hot-tapping or corresponding equipment.)

Tighten the ball valve securely onto the mounting base (shut off the ball valve).

Unscrew the locating sleeve and loosen the lock ring, retract the transducer into the joint nut, and then tighten the joint nut onto the ball valve.

Open the ball valve and insert the transducer into the pipe. At the same time, measure the dimension between the outside pipe and the A point (See Figure 2) and make sure it complies with the following formula:

$$H=237 - h$$

In this formula:

H is Mounting height (mm)

237 is Transducer length (mm)

h is Pipe wall thickness (mm)

Attach the lock ring to the joint nut by fitting its pinhole in the locating pin, then tighten the screw slightly and turn the orientation handle until it points at the middle position between the two transducers and its axes matches the axes of the pipeline. Finally, tighten the locking screw and screw the locating sleeve onto the joint nut.

Connect the transducer cables to the corresponding upstream/downstream (upstream=red, downstream=blue) terminal ends.







Important

For horizontal pipelines, transducers must be fixed on the sides of the pipe (i.e. at the 3 and 9 o’clock position of the pipe) to prevent signal attenuation caused by sediment on the bottom of the pipe or air bubbles and air pockets in the top of the pipe.

10.4 WH Type Insertion Transducer Pipe Parameter Entry Shortcuts

For example, measuring the diameter of DN200, pipe outside diameter is 219mm, pipe wall thickness is 6mm, pipe inner diameter is 207mm, measuring medium is water, and material is carbon steel, no liner, can be operated as follows:





Step1. Pipe outside diameter:

Press    keys to enter the window M11 and enter the pipe outside diameter, and then press  key to confirm.

Pipe Outer Diameter
207mm

(For insertion transducer, M11 menu need to be entered the pipe inner diameter)

Step2. Pipe wall thickness

Press    key to enter the window M12, and enter the pipe wall thickness, and press  key to confirm.

Pipe Wall Thickness
0.01mm

(The Wall Thickness needs to be 0.01mm for use with insertion sensors.)

Step3. Pipe Material

Press keys to enter the window M14, press key, press or key to select Pipe Material, and press key to confirm.

Pipe Material [14]
0.Carbon Steel

Step4. Transducers type

Press keys to enter the window M23, press or key to select transducer type, and press key to confirm.

Transducer Type [23]
3.Plug in WH101

3. Plug — in Type WH101 (WH type insertion transducer).

Step5. Transducer mounting methods

Press keys to enter the window M24, press key, press or key to select transducer-mounting method, and press key to confirm.

Transducer Mounting
1. Z

Choose according to the pipes on site.

Step6. Adjust Transducer spacing

Press keys to enter the window M25, accurately install the transducer according to the displayed transducer mounting spacing and the selected mounting method (Refer to Installing the Transducers in this chapter).

Transducer Spacing
68.83mm

Step7. Display measurement result

Press keys to enter the window M01.

Flow 0.1129 m3/h *R
Vel 1.0415m/s

About other setup, please refer to the related information in the manual.

10.5 WH Type Transducer Mounting Methods

Two transducer-mounting methods are available. Select one of them in the menu according to specific application conditions. They are: Z method, V method.

10.5.1 Z Mounting Method

Z method is the most commonly used mounting method for insertion-type ultrasonic flowmeters, suitable for pipe diameters ranging from 50 mm to 5000 mm. Due to strong signal strength and high measurement accuracy, the Z method is preferable for pipe sections severely rusted or with too much scale formation on the inside wall. When installing the transducer by using the Z method, be sure that the two transducers and the pipeline center axis are in the same plane, but never in the 6 or 12 o'clock positions. See below:

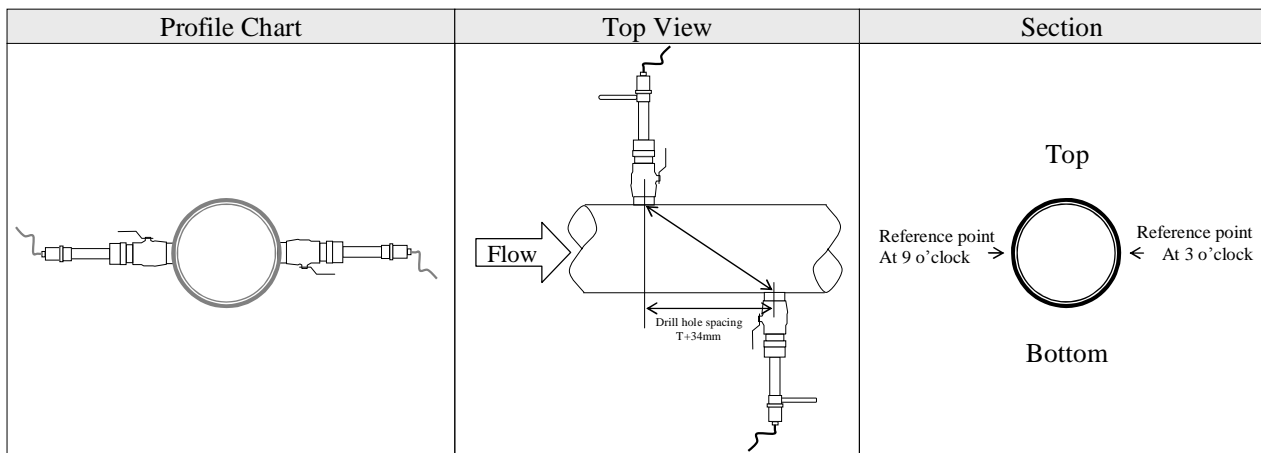

10.5.2 V Mounting Method

V method is suitable for pipe diameters ranging from 300mm to 1200mm. It is used when only one side of the pipe is available (example: the other side is against a wall) at the installation site, See below:

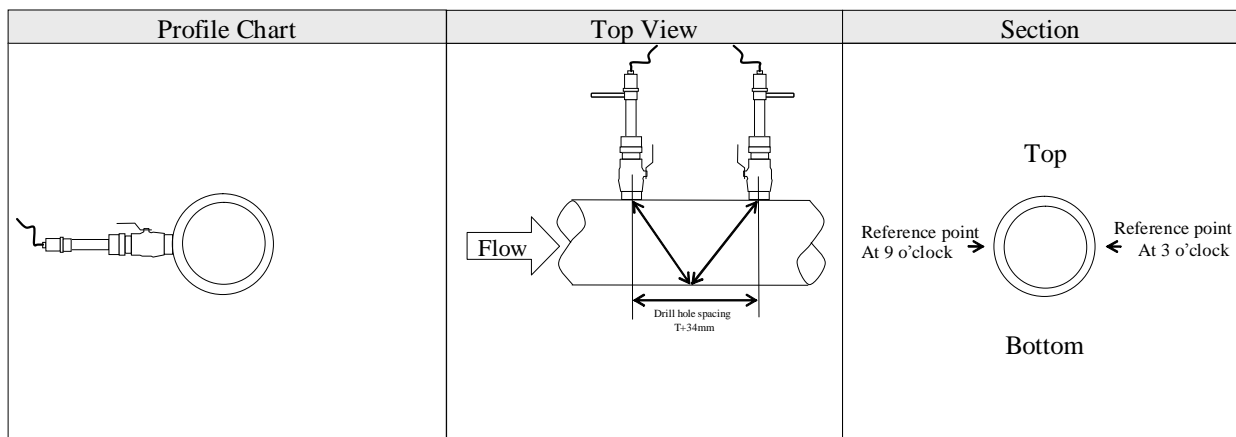

11. Appendix4 – Serial Interface Network Use and Communications Protocol

11.1 Overview

The flowmeter has perfect communication protocol. It can also be connected to a RS-485 bus .

Two basic schemes can be chosen for networking, i.e. the analog current output method only using the flowmeter or the RS232 communication method via serial port directly from the flowmeter. This method is suitable to replace dated instruments in old monitoring networks. The later method is used in new monitoring network systems. It has advantages include low hardware investment and reliable system operation.

When the serial port communications method is directly used to implement a monitoring network system, the address identification code (in window M46) of the flowmeter is used as a network address code. Expanded command set with [W] is used as communication protocol. Thus the analog current loop and OCT output of flowmeter can be used to control the opening/closing of a control valve. The relay output can be used to power-on/off other equipment. The analog input of the system can be used to input signals such as pressure and temperature. The system provides an RTU function for flow measurement.

RS-232 (cable length 0 ~ 15m) or RS-485 (cable length 0 ~ 1000m) can be directly used for data transmission links for a short distance. Current loop can be used in medium or long distance transmission.

When the flowmeter is used in a network environment, various operations can be performed by a host device, except for programming of the address identification code, which needs to be done via the flowmeter keyboard.

The command answer mode is used in data transmission, i.e. the host device issues commands and the flowmeter answers correspondingly.

Common/special flow / thermal data monitoring system developed by our company can be used for flow data collection. Based on characteristics of the flowmeter, the system makes full use of software and hardware designs with flowmeter features. The system is simple, clear, economical, and reliable in operation.



Attention

In the communication protocol used functions, RS232 and RS485 serial communications can not be used at the same time.

11.2 Serial Port Definitions

Flowmeter - RS232:	PIN 3 TXD send
TXD send	PIN 4 ground
RXD receive	PIN 5 ground
GND ground	PIN 6 empty
PC:	PIN 7 empty
PIN 1 empty	PIN 8 empty
PIN 2 RXD send	PIN9empty

11.3 Direct connection via RS232 to the host device

See the below list of flowmeter serial port definitions.

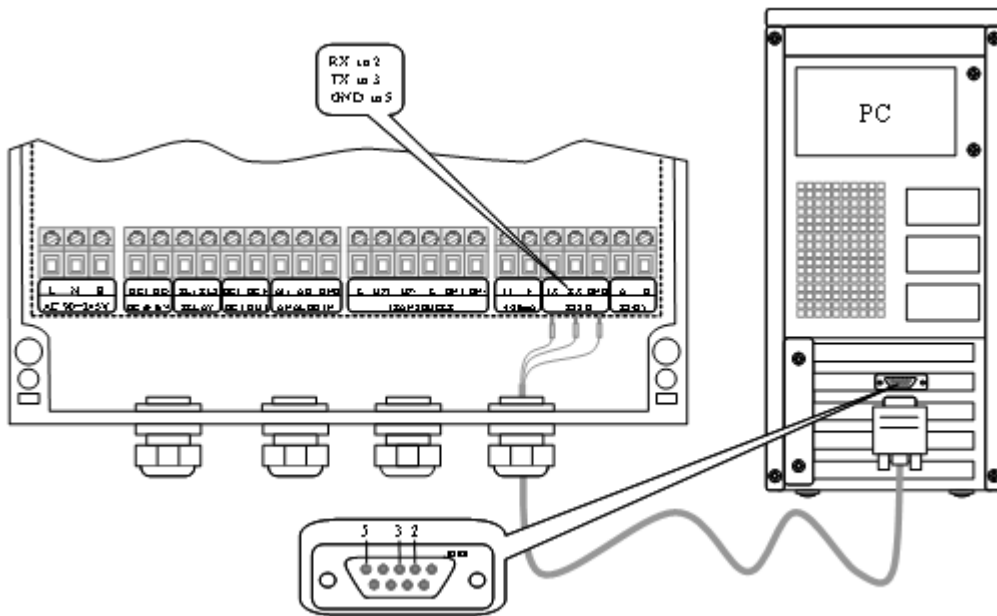

11.4 Communications Protocol and the Use

The flowmeter meter supports these three communication protocols: FUJI Protocol, MODBUS-C Protocol, MODBUS Protocol.

11.4.1 FUJI Protocol

Choose "0.FUJI" in Menu 96 for FUJI Protocol.

The communication protocol format used by the ultrasonic flowmeter is an expanded set of the Fuji FLV series flowmeter protocol. The host device requests the flowmeter to answer by sending a "command". The baud rate of asynchronous communication (Primary station: computer system; Secondary station: ultrasonic flowmeter) is generally 9600BPS. A single byte data format (10 bits): one start bit, one stop bit and 8 data bits. Check bit: none.

A data character string is used to express basic commands and a carriage return (ENTER) is used to express the end of a command. The characteristic is that the string of data is flexible. The order applies to both RS232 and RS485. Frequently used commands are as follows:

Communications commands

Command	Description	Data format
DQD(cr)(lf)注 0	Return daily instantaneous flow	±d.dddE±dd(cr)*1
DQH(cr)(lf)	Return hourly instantaneous flow	±d.dddE±dd(cr)
DQM(cr) (lf)	Return instantaneous flow per minute	±d.dddE±dd(cr)
DQS(cr) (lf)	Return instantaneous flow per second	±d.dddE±dd(cr)
DV(cr) (lf)	Return instantaneous velocity	±d.dddE±dd(cr)
DI+(cr) (lf)	Return positive accumulative flow	±d.dddE±d(cr)82
DI-(cr) (lf)	Return negative accumulative flow	±d.dddE±d(cr)

DIN(cr) (lf)	Return net accumulative flow	±dddddddE±d(cr)
DIE(cr) (lf)	Return totalized energy value	±dddddddE±d(cr)
E(cr) (lf)	Return instantaneous energy value	±dddddddE±d(cr)
AI1(cr) (lf)	Return analog input value of AI1 (Temperature, Pressure, etc.)	±dddddddE±d(cr)
AI2(cr) (lf)	Return analog input value of AI2 (Temperature, Pressure, etc.)	±dddddddE±d(cr)
AI3(cr) (lf)	Return analog input value of AI3 (Temperature, Pressure, etc.)	±dddddddE±d(cr)
DID(cr) (lf)	Return identification code of instrument (address code)	dddd(cr) 5 bits in length
DL(cr) (lf)	Return signal intensity	UP:dd.d, DN:dd.d, Q=dd(cr)
DS(cr) (lf)	Return percentage of analogous output (AO)	±d.dddddE±dd(cr)
DC(cr) (lf)	Return current error code	*3
DA(cr) (lf)	Alarm signal of OCT or RELAY	TR:s, RL:s(cr)*4
DT(cr) (lf)	Current date and time	yy-mm-dd, hh:mm:ss(cr)
M@(cr) (lf)	Analogous key value @ sent to flowmeter	M@(cr)*5
LCD(cr) (lf)	Return currently displayed content on LCD display	
C1(cr) (lf)	OCT actuated	
C0(cr) (lf)	OCT not actuated	
R1(cr) (lf)	RELAY actuated	
R0(cr) (lf)	RELAY not actuated	
FOddd(cr) (lf)	Frequency output value n	Fddd(cr)(lf)
Aoa(cr) (lf)	Current output value a of current loop	AOa(cr)(lf)*6
ESN(cr) (lf)	Return electronic serial number	ddddddt(cr)(lf)*7
W	Networking command prefix of numeric string address	*8
P	Prefix of return command with check	
&	Function sign of command "add"	

RING(cr)(lf)	Modem request handshake command	ATA(cr)(lf)
OK(cr) (lf)	Modem answer signal	No output
TEST(cr) (lf)	Test if there is a SD card or not.	There is a card ,then return "OK!",NO SD Card , then return "NOCARD".
DELETyymmdd(cr) (lf)	Delete the file"yymmdd", (yy: year, mm: month, dd: day.)	Successfully delete it, then return "OK!"; if not ,return "NOCARD".
READyymmdd(cr) (lf)	Read the file"yymmdd", (yy: year, mm: month, dd: day.)	Successfully delete it, then return the file contents; if not, return "NOCARD".
STOP(cr) (lf)	Stop the data storage	Successfully delete it, then return "OK!"; if not ,return "NOCARD".
START(cr) (lf)	Start the data storage	Successfully delete it, then return "OK!"; if not ,return "NOCARD".

Note:

0. (cr)expresses carriage return. Its ASCII value is 0DH. (lf) expresses line feed. Its ASCII value is 0AH.
1. "d" expresses 0-9 number. 0 value is expressed as +0.000000E+00.
2. "d" expresses 0-9 numbers. There is no decimal point in integral part before "E".
3. The status of the machine is expressed by 1-6 letters. See the error code section for the meaning of the characters. For example, "R" and "IH".
4. "s" expresses ON or OFF or UD. For example, "TR:ON, RL:ON" expresses that the OCT and relay are in an actuated status; "TR:UD, RL:UD" expresses that the OCT and relay are not actuated.
5. "@" expresses the key value. For example, 30H expresses "0" key; Command "M4" is equivalent to pressing the key "4".
6. "a" expresses the current value. The value range is 0-20. For example, AO2.34567 and AO0.2.
7. Eight "ddddddd" expresses the electronic serial number of the machine. "t" expresses the type of machine.
8. If there are multiple flowmeters in a data network then the basic commands cannot be used alone. The prefix W must be added. Otherwise, multiple flowmeters will answer simultaneously, which will cause chaos in the system.

1. Function prefix and function sign

1) Prefix P

The character P can be added before every basic command. It means that the transferred data has CRC verification. The method of counting the verified sum is achieved by binary system addition.

For example: Command DI+(CR) (the relative binary system data is 44H, 49H, 2BH, 0DH) transferred data is + 1234567E+0m3. (CR) (the relative binary system data is 2BH, 31H, 32H, 33H, 34H, 35H, 36H, 37H, 45H, 2BH, 30H, 6DH, 33H, 20H, 0DH, 0AH). And command PDI + (CR) transferred data is +1234567E+0m3! F7 (CR), "!" means the character before it is the sum character, and the verified sum of the two bytes after it is (2BH+31H+32H+33H+34H+35H+ 36H+37H+45H+2BH+30H+6DH+33H+20H = (2) F7H).

Note: There can be no data before " ! ", and also may be a blank character.

2) Prefix W

Usage of prefix W: W+ numeric string address code +basic command. Value range of the numeric string is 0 ~ 65535, except 13 (0DH carriage return), 10 (0AH line feed), 42 (2AH *) and 38 (26H &). If the instantaneous velocity of No. 12345 flowmeter is to be accessed, the command W12345DV(CR) can be issued. Corresponding

binary code is 57H, 31H, 32H, 33H, 34H, 35H, 44H, 56H and 0DH.

3) Function sign &

Function sign & can add up to 5 basic commands (Prefix P is allowed) together to form a compound command sent to the flowmeter together. The flowmeter will answer simultaneously. For example, if No. 4321 flowmeter is requested to simultaneously return: 1] instantaneous flow, 2] instantaneous flow velocity, 3] positive total flow, 4] energy total, 5] All analogous input current value, the following command is issued:

W4321PDQD & PDV&PDI + &PDIE&PBA1 (CR)

Simultaneously returned data are likely as follows:

+0.000000E+00m3/d!AC(CR)

+0.000000E+00m/s!88(CR)

+1234567E+0m3 !F7(CR)

















+0.000000E+0GJ!DA(CR)

+7.838879E+00mA!59(CR)

2. Key Code

In a network environment, a key code is used to simulate the use of keys at the host device.

For example, the instruction "M1" is input through the serial port, which is equivalent to pressing Key 1 on the keyboard of the ultrasonic flowmeter. Codes:

Key	Key Code (Hexadecimal system)	Key Code (Decimal system)	ASCII
	30H	48	0
	31H	49	1
	32H	50	2
	33H	51	3
	34H	52	4
	35H	53	5
	36H	54	6
	37H	55	7
	38H	56	8
	39H	57	9
	3AH	58	:
	3BH (0BH)	59	;
	3CH (0CH)	60	<
	3DH (0DH)	61	=
	3EH	62	>
	3FH	63	?

11.4.2 MODBUS Communication Protocol

This MODBUS Protocol uses RTU transmission mode. The Verification Code uses CRC-16-IBM (polynomial is $X^{16}+X^{15}+X^2+1$, shield character is 0xA001) which is gained by the cyclic redundancy algorithm method.

MODBUS RTU mode uses hexadecimals to transmit data.

1. MODBUS Protocol Function Code and Format

The flow meter protocol supports the following two-function codes of the MODBUS:

Function Code	Performance data
0x03	Read register
0x06	Write single register

2. MODBUS Protocol function code 0x03 usage

The host sends out the read register information frame format:

Slave Address	Operation Function Code	First Address Register	Register Number	Verify Code
1 byte	1 byte	2 bytes	2 bytes	2 bytes
0x01 ~ 0xF7	0x03	0x0000 ~ 0xFFFF	0x0000 ~ 0x7D	CRC (Verify)

The slave returns the data frame format:

Slave Address	Read Operation Function Code	Number of Data Bytes	Data Bytes	Verify Code
1 byte	1 byte	1 byte	N*x2 byte	2 bytes
0x01 ~ 0xF7	0x03	2xN*	N*x2 (Data)	CRC (Verify)

N* = Data register number

3. MODBUS Protocol function code 0x06 usage

The host sends a command to write a single register information frame format (function code 0x06):

Slave Address	Operation Function Code	Register Address	Register Data	Verify Code
1 byte	1 byte	2 bytes	2 bytes	2 bytes
0x01 ~ 0xF7	0x06	0x0000 ~ 0xFFFF	0x0000 ~ 0xFFFF	CRC (Verify)

The slave returns the data frame format (function code 0x06):

Slave Address	Operation Function Code	Register Address	Register Data	Verify Code
1 byte	1 byte	2 bytes	2 bytes	2 bytes

0x01 ~ 0xF7	0x06	0x0000 ~ 0xFFFF	0x0000 ~ 0xFFFF	CRC (Verify)
-------------	------	-----------------	-----------------	----------------

The range of flow meter addresses 1 to 247 (Hexadecimal: 0x01 ~ 0xF7), and can be checked in the Menu 46. For example, decimal number "11" displayed on Menu 46 means the address of the flow meter in the MODBUS protocol is 0x0B.

The CRC Verify Code adopts CRC-16-IBM (polynomial is $X^{16}+X^{15}+X^2+1$, shield character is 0xA001) which is gained by the cyclic redundancy algorithm method. Low byte of the verify code is at the beginning while the high byte is at the end.

For example, to read the address 1 (0x01) in the RTU mode, if the instantaneous flow rate uses hour as a unit (m³/h) , namely reads 40005 and 40006 registers data, the read command is as follows:

0x01 0x03 0x00 0x04 0x00 0x02 0x85 0xCA

Flowmeter Address Function Code First Address Register Register Numbers CRC Verify Code

Flowmeter returned data is (assuming the current flow=1.234567m³/h)

0x01 0x03 0x04 0x06 0x51 0x3F 0x9E 0x3B 0x32

Flowmeter Address Function Code Data Bytes Data (1.2345678) CRC Verify Code

The four bytes 3F 9E 06 51 is in the IEEE754 format single precision floating point form of 1.2345678.

Pay attention to the data storage order of the above example. Using C language to explain the data, pointers can be used directly to input the required data in the corresponding variable address, the low byte will be put at the beginning, such as the above example 1.2345678 m/s, 3F 9E 06 51 data stored in order as 51 06 9E 3F.

For example, it converts the address 1 (0x01) to 2 (0x02) under the RTU mode, so to write the data of flowmeter 44100 register as 0x02, the write command is as follows:

0x01 0x06 0x10 0x03 0x00 0x02 0xFC 0xCB

Flowmeter Address Function Code Register Address Register Number CRC Verify Code

Flowmeter returned data is:

0x01 0x06 0x10 0x03 0x00 0x02 0xFC 0xCB

Flowmeter Address Function Code Register Address Register Number CRC Verify Code

4.Error Check

The flowmeter only returns one error code 0x02 which means data first address in error.

For example, to read address 1 (0x01) of the flowmeter 40002 register data in the RTU mode, the flowmeter considers it to be invalid data, and sends the following command:

0x01 0x03 0x00 0x01 0x00 0x01 0xD5 0xCA

Flowmeter Address Function Code Register Address Register Number CRC Verify Code

Flowmeter returned error code is:

0x01 0x83 0x02 0xC0 0xF1

Flowmeter Address Error Code Error Extended Code CRC Verify Code

5.MODBUS Register Address List

The flowmeter MODBUS Register has a read register and a write single register.

- a. Read Register Address List (use 0x03 function code to read)

PDU Address	Register	Read	Write	Type	No. registers*
\$0000	40001	Flow/s - low word	32 bits real	2	
\$0001	40002	Flow/s - high word			
\$0002	40003	Flow/m - low word	32 bits real	2	
\$0003	40004	Flow/m- high word			
\$0004	40005	Flow/h - low word	32 bits real	2	
\$0005	40006	Flow/h - high word			
\$0006	40007	Velocity – low word	32 bits real	2	
\$0007	40008	Velocity – high word			
\$0008	40009	Positive total – low word	32 bits int.	2	
\$0009	40010	Positive total – high word			
\$000A	40011	Positive total – exponent	16 bits int.	1	
\$000B	40012	Negative total – low word	32 bits int.	2	
\$000C	40013	Negative total – high word			
\$000D	40014	Negative total – exponent	16 bits int.	1	
\$000E	40015	Net total – low word	32 bits int.	2	
\$000F	40016	Net total – high word			
\$0010	40017	Net total – exponent	16 bits int.	1	
\$0011	40018	Energy total – low word	32 bits int.	2	
\$0012	40019	Energy total – high word			
\$0013	40020	Energy total – exponent	16 bits int.	1	
\$0014	40021	Energy flow – low word	32 bits real	2	
\$0015	40022	Energy flow – high word			
\$0016	40023	Up signal int – low word	32 bits real	2	0 ~ 99.9
\$0017	40024	Up signal int – high word			
\$0018	40025	Down signal int – low word	32 bits real	2	0 ~ 99.9
\$0019	40026	Down signal int – high word			
\$001A	40027	Quality	16 bits int.	1	0 ~ 99
\$001B	40028	Analog output – low word	32 bits real	2	Unit: mA
\$001C	40029	Analog output – high word			
\$001D	40030	Error code – char 1,2	String	3	Refer to "Error Analysis" for detailed codes meanings.
\$001E	40031	Error code – char 3,4			
\$001F	40032	Error code – char 5,6			
\$003B	40060	Velocity unit – char 1,2	String	2	Currently supports m/s only
\$003C	40061	Velocity unit – char 3,4			
\$003D	40062	Flow unit – char 1,2	String	2	Note 1
\$003E	40063	Flow unit – char 3,4			
\$003F	40064	Total unit – char 1,2	String	1	Note 2- the setup is same as M84.
\$0040	40065	Energy unit – char 1,2	String	2	
\$0041	40066	Energy unit – char 3,4			
\$0042	40067	Energy total unit – char 1,2	String	1	
\$0043	40068	ID code – low word	32 bits int.	2	
\$0044	40069	ID code – high word			
\$0045	40070	Serial number – char 1,2	String	4	
\$0046	40071	Serial number – char 3,4			
\$0047	40072	Serial number – char 5,6			
\$0048	40073	Serial number – char 7,8			
\$0049	40074	Analog Input AII Value- low word	32 bits real	2	Returned temperature

\$004a	40075	Analog Input AI1 Value- high word			value with RTD option
\$004b	40076	Analog Input AI2 Value- low word	32 bits real	2	Returned temperature value with RTD option
\$004c	40077	Analog Input AI2 Value- high word			

b. Single Write Register Address List (use 0x06 performance code to write)

PDU Address	Register	Description	Read/Write	Type	No. registers*
\$1003	44100	Flowmeter address (1 - 247)	R/W	16 bits int.	1
\$1004	44101	Communication Baud Rate 1 = 4800, 2 = 9600, 3 = 19K2, 4 = 38K4 ,5 = 57K6	R/W	16 bits int.	1

Notes:

1.The following flow rate units are available:

0. "m3" — Cubic Meter
1. "l" — Liters
2. "ga" — Gallons
3. "ig" — Imperial Gallons
4. "mg" — Million Gallons
5. "cf" — Cubic Feet
6. "ba" — US Barrels
7. "ib" — Imperial Barrels
8. "ob" — Oil Barrels

2.The following energy units are available:

9. "GJ" — Giga Joule
10. "Kc" — Kilocalorie
11. "MB" — MBtu
12. "KJ" — Kilojoule
13. "Bt" — Btu
14. "Ts" — US Tonnes
15. "Tn" — US Tons
16. "kw" — Kwh

3.When the flowmeter address or communication baud rate change, the meter will work under the new address or communication baud rate after the communication baud rate responded with returned primary address and communication baud rate.

4.16 bits int—short integer, 32 bits int - long integer, 32 bits real—floating point number, String—alphabetic string.

12. Appendix5–RTD Module and PT1000 Wiring (Module Optional)

12.1 RTD Energy Meter Function

This function is applied to the following meter and measurement temperature range:

D118 Hot (Cold) Energy Meter: 0 ~ 180 °C, equipped with PT1000 temperature sensor.

The RTD Module's main function is to input the temperature values for the energy measurement. The D118 can automatically calculate the caloric content of water at different temperatures and obtain an instantaneous energy value and totalized energy value.

12.2 Wiring (PT1000)

Three - wire connections methods is used for the RTD module and PT1000 temperature sensors, connections methods is as follows. (Note: A1, A2 are the same color, B1 and B2 are the same color).

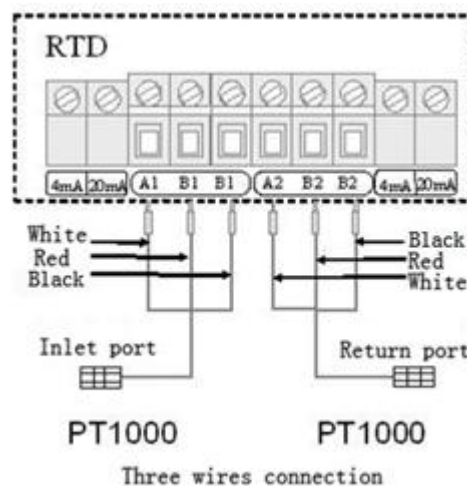

The two PT1000 temperature sensors are installed on the inlet and return pipes and they will input temperature signals to the D118 transmitter.

12.3 Energy Measurement Methods

Energy Measurement Methods:

Formula: $Q = m (h_1 - h_2)$

Q—Energy Value

m—quality of the medium(density× transit time water volume)

h1—enthalpy value of the inlet water

h2—enthalpy value of the return water























The temperature and pressure at the inlet and return water points can be measured by temperature sensors and a transmitter, and pressure sensors and a transmitter. Then the enthalpy value at the inlet and return water points can be calculated through the enthalpy values table. The flow of the medium can be measured via the ultrasonic flow sensors and D118 transmitter, and the caloric value can be derived according to the above formulas and the caloric calibration index.

12.4 Temperature Calibration Methods

Method: Resistance box calibration method

Note: The purpose is to calibrate the internal circuit of RTD module

Tools needed: one DC resistance box, 3 wires (each wire less than 40mm length), and an instrument screwdriver.

1. Connect RTD module A1 to one end of the DC resistance box, and B1 to the other end of the DC resistance box, and then connect A2 to one end of the DC resistance box, and B2 to the other end of the DC resistance box.
2. Power the transmitter on and then enter menu M07.
3. Set resistance value of the DC resistance box to be 1000.00 Ω .
4. Clockwise or counterclockwise adjust the 4mA potentiometer on the left of A1 and the 4mA potentiometer on the right of A2, and make sure the display of inlet water temperature and return water temperature is 0.00 ± 0.1 .
5. Press     keys, input code "115800", then press  key to stretch. Only in the current powering -on period, automatically shut down when the power is cut off.
6. Press  key to enter and then select "Adjust 0" to return water temperature adjustment, press   to adjust temperature for 0.00, Press  key to enter and then select "Adjust 0" to inlet water temperature adjustment, press   to adjust temperature for 0.00, Press  key to Complete calibration.
7. Set the resistance value of two DC Resistance boxes to be 1684.80 Ω .
8. Enter the menu M07, after waiting for two temperature stability press     keys to enter and select "Adjust 100" to return water temperature adjustment, press   to adjust temperature for 180. Press  key to enter inlet water temperature 180 $^{\circ}\text{C}$ adjustment, press   to adjust temperature for 180, press  key to Complete calibration.
9. Power on for many times, 0 $^{\circ}\text{C}$: inlet and return water temperature is 0.00 ± 0.05 , Temperature difference is 0.00 ± 0.05 . 180 $^{\circ}\text{C}$: inlet and return water temperature is 180 ± 0.05 , Temperature difference is 0.00 ± 0.05 .

13. Appendix6– Energy Meter

Note: For D118, there are 2 methods to perform energy meter function:



1. If the customer does not select the RTD module, then the AI1 AI2 (4~20mA input ports) are open to connect temperature transmitters supplied by the customer.
2. If the customer chooses to select the RTD module, then the AI1, AI2 inputs can not be used.

13.1 Energy Meter Function

The flowmeter has an energy meter function. The meter can calculate automatically caloric content of water under various temperatures, and obtain instantaneous caloric value and totalized caloric value. A separate customer-provided Temperature signal input is sent to the meter via the AI1, AI2 terminals, which can be configured for a 4 ~ 20mA or 0 ~ 20mA current signal.

13.2 Wiring

AI1, AI2 are connected with 2 temperature sensors by connection cable. The 2 temperature sensors are installed on the flow pipe and return pipe, they can input 4-20mA signals to AI1, AI2 of the transmitter (see wiring connection).

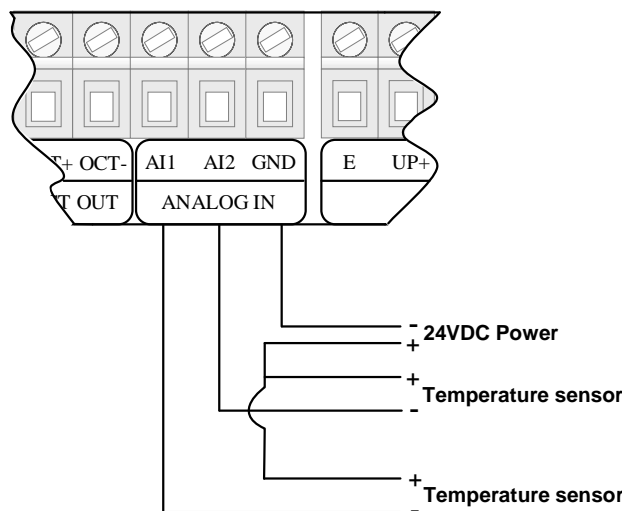

13.3 Energy Calculation Method

The flowmeter has 2 calculation methods to achieve energy value:

Formula 1: Energy (caloric quantity) = Flow Value Difference in Temperature × Specific Heat

Note:

Select Energy units in window M84

Difference in Temperature: Difference in 2 analog input AI1, AI2 (transmitted from 2 temperature sensors)

Specific Heat: Input specific heat value in window M86, generally select Fixed Specific Heat value 0.0041868GJ/M3 for Water

Formula 2: Energy (caloric quantity) = Flow Value × Difference in Energy AI1 and Energy AI2

Energy (Instantaneous Caloric/Totalized Caloric) can be calculated automatically and display in window M05.

If the difference in Temperature is a fixed value, the meter can calculate Energy directly without temperature sensors. Enter Fixed Difference in Temperature value in window M85.

For example, we know Fixed Difference is 10°C, press **Menu** **dys.** **8** **ENTER** **5** **ENTER** **V** to select“1”. Fixed Difference”, enter **pipe** **1** **cal.** **0** key. Energy can be calculated automatically and display in window M05.

13.4 Set Temperature Value Range

Input temperature signal via AI1, AI2 terminals, set its measurement range in window M63 and window M64.

For example, the inlet temperature sensor outputs a 4-20mA current signal to the meter, and this is set to represent a temperature range of 10°C to 50°C. Connect this sensor to the AI1 terminal, enter 10, 150 in window M63. Current mA value and temperature value of AI1 will display in window M06. The same procedure is then followed for the outlet temperature sensor; the zero and span for this sensor is entered into window M64.

Related energy meter window as follows:

Window M05: Display energy and totalized energy

Window M06: Display AI1, AI2 current value and the corresponding temperature value

Window M63: Enter temperature value which AI1 4mA and 20mA analog input represent

Window M64: Enter temperature value which AI2 4mA and 20mA analog input represent

Window M84: Select energy units

Window M85: Select temperature source

Window M86: Specific heat value

Window M88: Select energy multiplier

Window M89: Reset energy totalizer.

14. Appendix7- Flow Application Data

14.1 Sound Velocity and Viscosity for Fluids Commonly Used

Fluid	Sound Velocity (m/s)	Viscosity
water 20°C	1482	1.0
water 50°C	1543	0.55
water 75°C	1554	0.39
water100°C	1543	0.29
water125°C	1511	0.25
water150°C	1466	0.21
water175°C	1401	0.18
water200°C	1333	0.15
water225°C	1249	0.14
water250°C	1156	0.12
Acetone	1190	
Carbinol	1121	

Ethanol	1168	
Alcohol	1440	1.5
Glycol	1620	
Glycerin	1923	1180
Gasoline	1250	0.80
Benzene	1330	
Toluene	1170	0.69
Kerosene	1420	2.3
Petroleum	1290	
Retinal	1280	
Aviation kerosene	1298	
Peanut oil	1472	
Castor oil	1502	

14.2 Sound Velocity for Various Materials Commonly Used

Pipe Material	Sound Velocity (m/s)
Steel	3206
ABS	2286
Aluminum	3048
Brass	2270
Cast iron	2460
Bronze	2270
Fiber glass-epoxy	3430
Glass	3276
Polyethylene	1950
PVC	2540

Liner Material	Sound Velocity
Teflon	1225
Titanium	3150
Cement	4190
Bitumen	2540
Porcelain enamel	2540
Glass	5970
Plastic	2280
Polyethylene	1600
PTFE	1450
Rubber	1600

14.3 Sound Velocity in Water (1 atm) at Different Temperatures

t(°C)	v(m/s)	t(°C)	v(m/s)	t(°C)	v(m/s)
0	1402.3	34	1517.7	68	1554.3
1	1407.3	35	1519.7	69	1554.5
2	1412.2	36	1521.7	70	1554.7
3	1416.9	37	1523.5	71	1554.9
4	1421.6	38	1525.3	72	1555.0
5	1426.1	39	1527.1	73	1555.0
6	1430.5	40	1528.8	74	1555.1
7	1434.8	41	1530.4	75	1555.1
8	1439.1	42	1532.0	76	1555.0
9	1443.2	43	1533.5	77	1554.9
10	1447.2	44	1534.9	78	1554.8
11	1451.1	45	1536.3	79	1554.6
12	1454.9	46	1537.7	80	1554.4
13	1458.7	47	1538.9	81	1554.2
14	1462.3	48	1540.2	82	1553.9
15	1465.8	49	1541.3	83	1553.6
16	1469.3	50	1542.5	84	1553.2
17	1472.7	51	1543.5	85	1552.8
18	1476.0	52	1544.6	86	1552.4
19	1479.1	53	1545.5	87	1552.0
20	1482.3	54	1546.4	88	1551.5
21	1485.3	55	1547.3	89	1551.0
22	1488.2	56	1548.1	90	1550.4
23	1491.1	57	1548.9	91	1549.8
24	1493.9	58	1549.6	92	1549.2
25	1496.6	59	1550.3	93	1548.5
26	1499.2	60	1550.9	94	1547.5
27	1501.8	61	1551.5	95	1547.1
28	1504.3	62	1552.0	96	1546.3
29	1506.7	63	1552.5	97	1545.6
30	1509.0	64	1553.0	98	1544.7
31	1511.3	65	1553.4	99	1543.9
32	1513.5	66	1553.7		
33	1515.7	67	1554.0		

Refer to the sound velocity of other fluids and materials, please contact the factory.