

POWER

CSU800AP

800 Watts Distributed Power System

Preliminary Data Sheet

Front-end Bulk Power
Total Output Power:
 800 W continuous
Wide Input Voltage:
 90 - 264 Vac; 164 - 320 Vdc



SPECIAL FEATURES

- 800 W output power
- High power and short form factor
- 1U power supply
- High density design: 25 W/in³
- Active Power Factor Correction
- EN61000-3-2 Harmonic compliance
- Inrush current control
- 80 PLUS® Platinum efficiency
- N+M redundant N+M ≤ 4
- Hot-pluggable
- Active current sharing
- Full digital control
- PMBus® compliant
- Accurate input power reporting
- EN61000-4-5 surge level 2kV/4kV DM/CM
- Compatible with Artesyn's Universal PMBus GUI
- Reverse airflow option

COMPLIANCE

- Conducted/Radiated EMI Class A
- EN61000-4-11

SAFETY

- IEC62368
- UL/cUL
- UL + CB Report
- CE Mark
- CCC
- BSMI
- KC
- TÜV

Electrical Specifications

Input						
Input range	90 - 264 Vac / 164 - 320 Vdc					
Frequency	47 Hz to 63 Hz					
Efficiency	80 PLUS® Platinum efficiency					
Max input current	11.7 Arms @ 90 Vac					
Inrush current	35 Apk					
Conducted EMI	Class A					
Radiated EMI	Class A					
Power factor	>0.9 beginning at 10% load					
ITHD	<10% beginning at 20% load					
Leakage current	1.75 mA					
Hold-up time	13 ms at full load					
Output						
	Main DC Output			Standby DC Output		
	MIN	NOM	MAX	MIN	NOM	MAX
Nominal setting (12 V / 1 A, 12 VSB / 0.1 A)	11.9	12.0	12.1	11.9	12.0	12.1
Total output regulation range	11.4 V		12.6 V	11.4 V		12.6 V
Dynamic load regulation range	11.4 V		12.6 V	11.4 V		12.6 V
Output ripple			120 mV			120 mV
Output current	1		66.7 A	0		3 A
Current sharing	Within ±5% @ full load rating			N/A		
Capacitive loading	500 µF		25000 µF	100 µF		3100 µF
Start-up from AC to output			3000 ms			1500 ms
Output rise time	5 ms		70 ms	1 ms		25 ms

Electrical Specifications

Protections (Main Output)					
	Minimum	Nominal	Maximum	Units	Comment
Peak current			76	A	
Output OCP	76		83.6	A	
Dynamic loading setup			±5	%	60% rated load step, 0.25 A/μs slew rate; 2000 μF / 1 A min
Output OVP	13.3		14.5	V	Latch
Output UVP	9.5		11.0	V	Latch
Overtemperature protection		Yes			
Fan fault protection		Yes			
Standby Output					
Output OCP	4.0		5.0	A	
Output OVP	13.3		14.5	V	
Dynamic loading setup			±5	%	50% rated load step Slew rate: 0.25 A / μs / 100 μF

Electrical Specifications

LED Indicators	
POWER SUPPLY CONDITION	LED STATE
Normal work	GREEN
No AC power to all power supplies	OFF
AC present / Only 12 VSB on (PS off) or PS in CR state	1 Hz Blink GREEN
AC cord unplugged; with a second power supply in parallel still with AC input power	RED
Power supply warning events where the power supply continues to operate; high temp, high power, high current, slow fan, input voltage lower than 90 Vac (not warning above 90 V condition, must be warning state below 85 V condition)	1 Hz Blink RED
Power supply critical event causing a shutdown; failure, OCP, OVP, fan fail	RED

Firmware Reporting And Monitoring

	Accuracy Range		
Output loading	10% to 30%	> 30% to 50%	> 50% to 100%
READ_PIN and READ_EIN	±5 W	±3%	±3%
READ_IOUT	±5%	±2%	±2%
READ_TEMPERATURE		±3 °C	

Timing Specifications

	Description	Min	Max	Unit
T_{vout_rise}	12 V main output voltage rise time	5.0	70	ms
	12 VSB output voltage rise time	1	25	ms
$T_{sb_on_delay}$	Delay from AC being applied to 12 Vsb being within regulation		1500	ms
$T_{ac_on_delay}$	Delay from AC being applied to all output voltages being within regulation		3000	ms
T_{vout_holdup}	Time 12 VI output voltage stay within regulation after loss of AC	13		ms
T_{pwok_holdup}	Delay from loss of AC to de-assertion of PWOK	12		ms
$T_{pson_on_delay}$	Delay from PSON# active to output voltages within regulation limits	5	400	ms
T_{pson_pwok}	Delay from PSON# deactivate to PWOK being de-asserted		5	ms
T_{pwok_on}	Delay from output voltages within regulation limits to PWOK asserted at turn on	100	500	ms
T_{pwok_off}	Delay from PWOK de-asserted to output voltages dropping out of regulation limits	1		ms
T_{pwok_low}	Duration of PWOK being in the de-asserted state during an off/on cycle using AC or the PSON signal	100		ms
T_{sb_vout}	Delay from 12VSB being in regulation to O/Ps being in regulation at AC turn on	50	1000	ms
T_{12VSB_holdup}	Time the 12VSB output voltage stays within regulation after loss of AC	70		ms

Timing Diagram

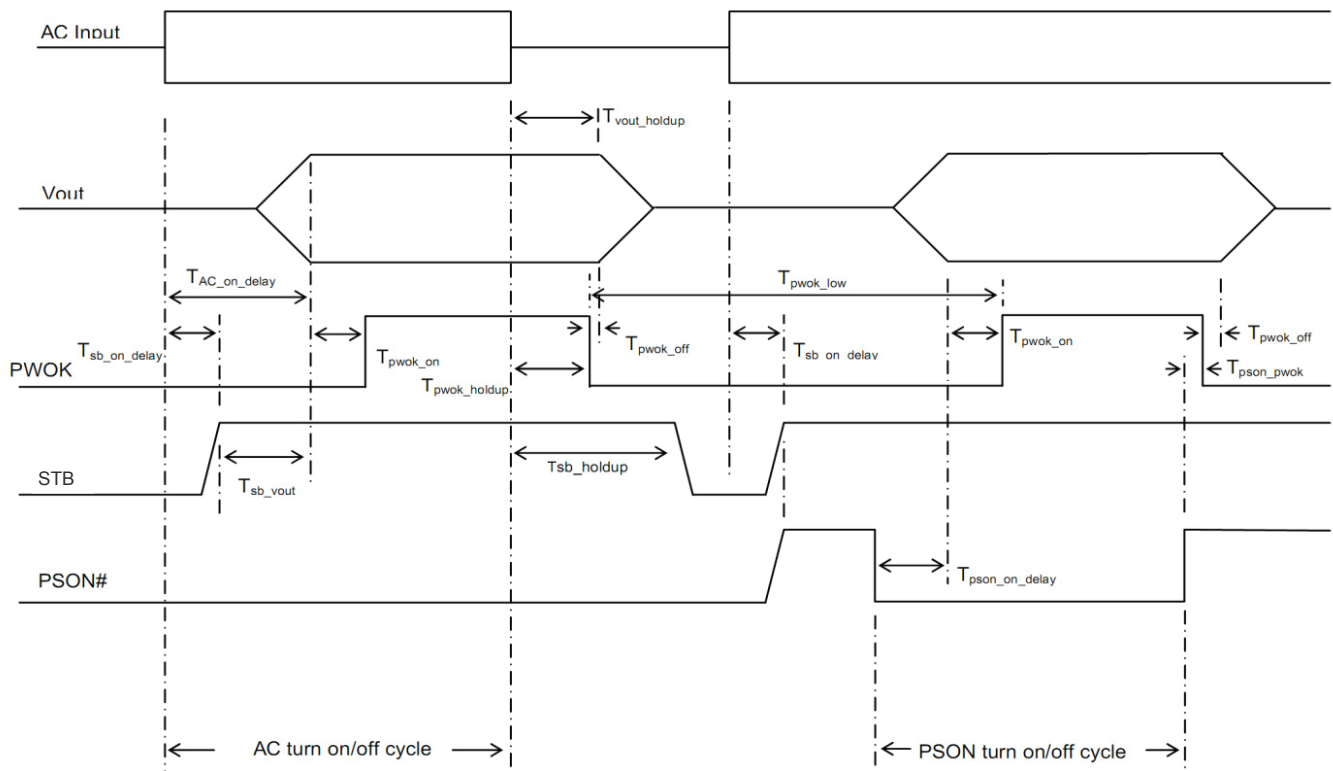

Environmental Specifications

Operating temperature	0 to 55 °C, the maximum operating temperature (55 °C) is to be derated by 1 °C per 300 m above 2000 m
Operating altitude	up to 5000 m
Operating humidity	+5% to +85% non-condensing
Storage temperature	-40 °C to +70 °C, non-condensing
Storage humidity	+5% to +95% non-condensing
Non-operating altitude	up to 15,200 meters
Vibration and shock	Standard operating/non-operating random shock and vibration
RoHS compliance	Yes
MTBF	250,000 hours per Telcordia Issue 2, Method 1, Case 3 at 25 °C ambient at full load

Mechanical Outline

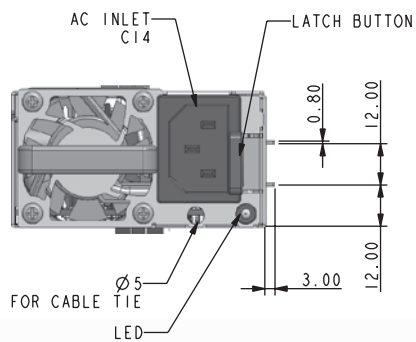
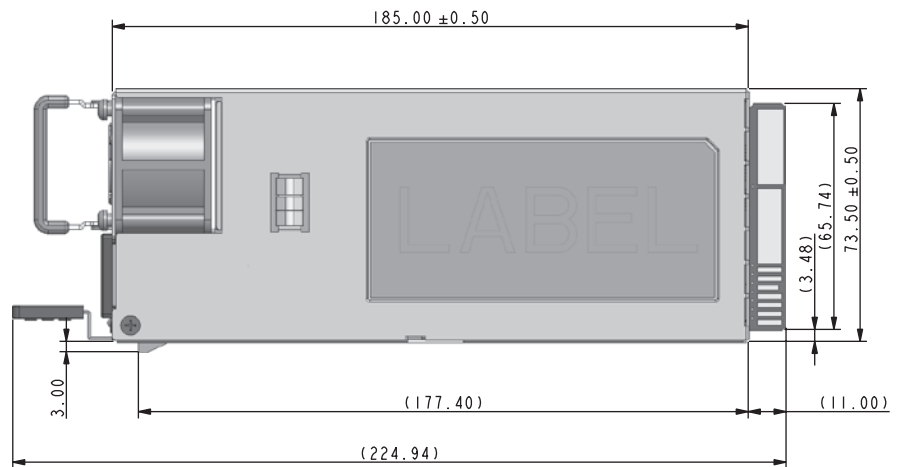

Power Supply Output Card Edge

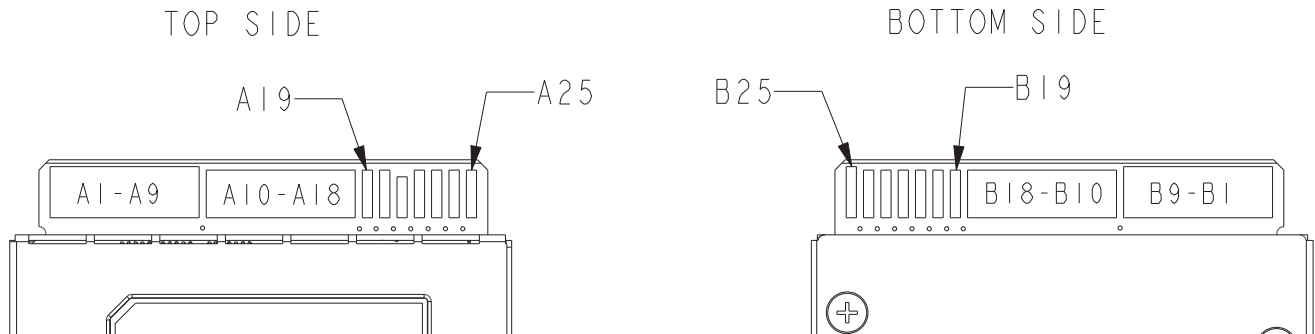

Connector Definitions

Output connector part number	Card-edge
Mating connector part number	2x25 pin configuration of the FCI power card connector 10035388-102LF

Output Connector Pin Configuration

Pin	Name	Pin	Name
A1-A9	GND	B1-B9	GND
A10-A18	+12 V	B10-B18	+12 V
A19	SDA	B19	A0 (SMBus address)
A20	SCL	B20	A1 (SMBus address)
A21	PSON	B21	12 VSB
A22	SMBAlert#	B22	CR_BUS#
A23	-VSENSE	B23	12 V load share
A24	+VSENSE	B24	Present
A25	PWOK	B25	Vin_Good

Ordering Information

Model number	Airflow	Nominal Output Voltage	Set Point	Regulation Band	Minimum Current	Maximum Current	Output Ripple P/P	Standby
CSU800AP-3-600	Normal fan	12.0 Vdc	11.9 - 12.1 Vdc	11.4 - 12.6 Vdc	1 A	66.7 A	120 mV	12.0 V @ 3 A
CSU800AP-3-601	Reverse fan	12.0 Vdc	11.9 - 12.1 Vdc	11.4 - 12.6 Vdc	1 A	66.7 A	120 mV	12.0 V @ 3 A

WORLDWIDE OFFICES

Americas

2900 South Diablo Way
Suite B100
Tempe, AZ 85282, USA
+1 888 412 7832

Europe (UK)

Ground Floor Offices, Barberry House
4 Harbour Buildings, Waterfront West
Brierley Hill, West Midlands
DY5 1LN, UK
+44 (0) 1384 842 211

Asia (HK)

14/F, Lu Plaza
2 Wing Yip Street
Kwun Tong, Kowloon
Hong Kong
+852 2176 3333

ARTESYNTM
An Advanced Energy Company

www.artesyn.com

Artesyn Embedded Technologies, Artesyn Embedded Power, Artesyn, and all Artesyn related logos are trademarks and service marks of Artesyn Embedded Technologies, Inc. All other names and logos referred to are trade names, trademarks, or registered trademarks of their respective owners. Specifications are subject to change without notice. © 2020 Artesyn Embedded Technologies, Inc. All rights reserved. For full legal terms and conditions, please visit www.artesyn.com/legal.

For more information: www.artesyn.com
For support: productsupport.ep@artesyn.com

CSU800AP DS 09Jul2020