

ROTARY BORE GAGE

INSIZE PLUS
MADE IN GERMANY

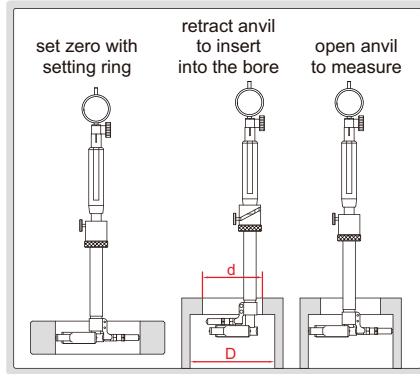

- Rotary anvil, to measure bores with small opening
D: bore diameter to be measured,
d: minimum opening diameter (see right drawing)
 $d=57\text{mm}$ ($D \leq 95\text{mm}$)
 $d=D-38$ ($D > 95\text{mm}$)
- Optional accessory:
 - 0.01mm or 0.001mm graduation dial indicator or dial comparator
 - Setting ring (code **6312**)

dial indicator
is optional



2921-150

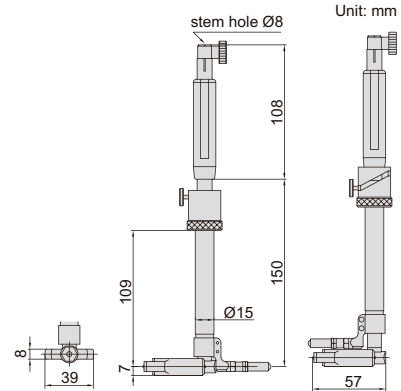

Code	Range	Accuracy (without dial indicator)	Repeatability * (without dial indicator)
2921-150	80-150mm	2µm	1µm

* Repeatability includes the error of rotary anvil