

### Vacuum Dehydration Oil Purification System(Oil Purifier)

The water and particles contamination in lubrication, hydraulic and dielectric oils badly affect the oils performance and threaten system reliability. The contaminants promote corrosion and fluid system component wear, resulting in reduced component life and increased maintenance costs, so removal of water, dissolved gases and particulate from lube oils, hydraulic fluids and insulating oils can extend reliability of systems, the life of system components and fluids.

ACORE designs and builds the most effective, reliable **VDF Vacuum Dehydration Oil Purification System(Vacuum Oil Purifier)**, which maintains completely clean and dry of liquids by continuous removal of particles, free and emulsified water, gas and sludge. Vacuum dehydration is the most effective method of free and dissolved water removal at minimum cost, it can achieve overall content down to 10 PPM. Using high performance rated multi-stage micron filter elements to removes particles as small as 1 micron with 99% efficiency. Meanwhile, **VDF Vacuum Oil Purifier** also can remove free, entrained and dissolved gases by vacuum distillation. It is very effective, durable, and user-friendly high vacuum dehydration oil purification system on the market today.

#### Features

1. High performance removal of water, gas and particulate
2. Low watt density oil heaters to prevent coking or burning of the oil
3. Remove 100% of free water and gases, and up to 80% of dissolved water and gases
4. Absolute rated particulate filters available in retention ratings from 1-100 microns
5. Dry-sealed rotary vane vacuum pump and positive displacement oil pumps
6. Phase reversing switch, dirty filter indication light and alarm condition lights for low oil level, high oil level, low flow, over-heat and over-load
7. Extension of fluid service life
  - Minimized corrosion within systems
  - Reduced fluid disposal
  - Reduced operating costs
  - Increased equipment reliability
  - Simple automated operation



## Applications of VDF Vacuum Oil Purifier

- Lubricating Oil
- Transformer Oil
- Hydraulic Liquid
- Turbine Oil
- Compressor Oil
- Cooling mineral oil
- Insulating Oil
- Gear Oil
- Engine Oil

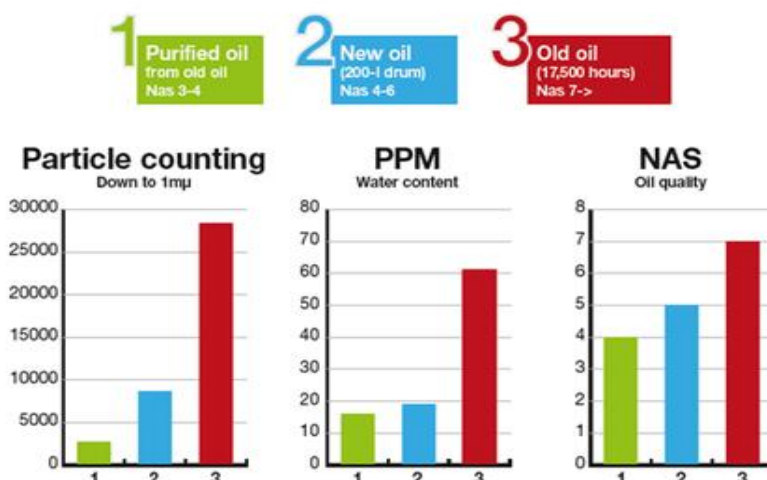

## Technical Specifications

Model	VDF-10	VDF-20	VDF-30	VDF-50	VDF-80	VDF-100	VDF-150	VDF-200	VDF-250	VDF-300	
Capacity(L/min)	10	20	30	50	80	100	150	200	250	300	
Working vacuum	-0.06~-0.095 Mpa										
Working pressure	≤ 0.4 Mpa										
Temperature range	20-80°C										
Water content	≤20 ppm										
Gas content	≤ 0.1%										
Demulsifying value	≤8 min(GB/F7035)										
Cleanness	NAS 4 grade										
Filtering precision	≤1 micron										
Continuous work	100 hr										
No failure running	≥5000 hr										
Power supply	380V, 50HZ, 3PH ( or Customized )										
Working noise	65 dB										
Heating power (kw)	24	24	30	35	40	60	90	120	140	150	
Total power (kw)	27	27	33	40	45	65	100	130	150	165	
Inlet/outlet(mm)	25	25	32	32	40	48	50	58	62	65	
Weight (kg)	300	350	400	500	650	800	1000	1200	1300	1350	
Dimension (mm)	L	1100	1150	1200	1300	1400	1500	1600	1700	1900	2000
	W	800	800	850	950	1000	1000	1150	1250	1300	1350
	H	1200	1250	1300	1350	1400	1500	1600	1800	1900	2000

## Flow Chart

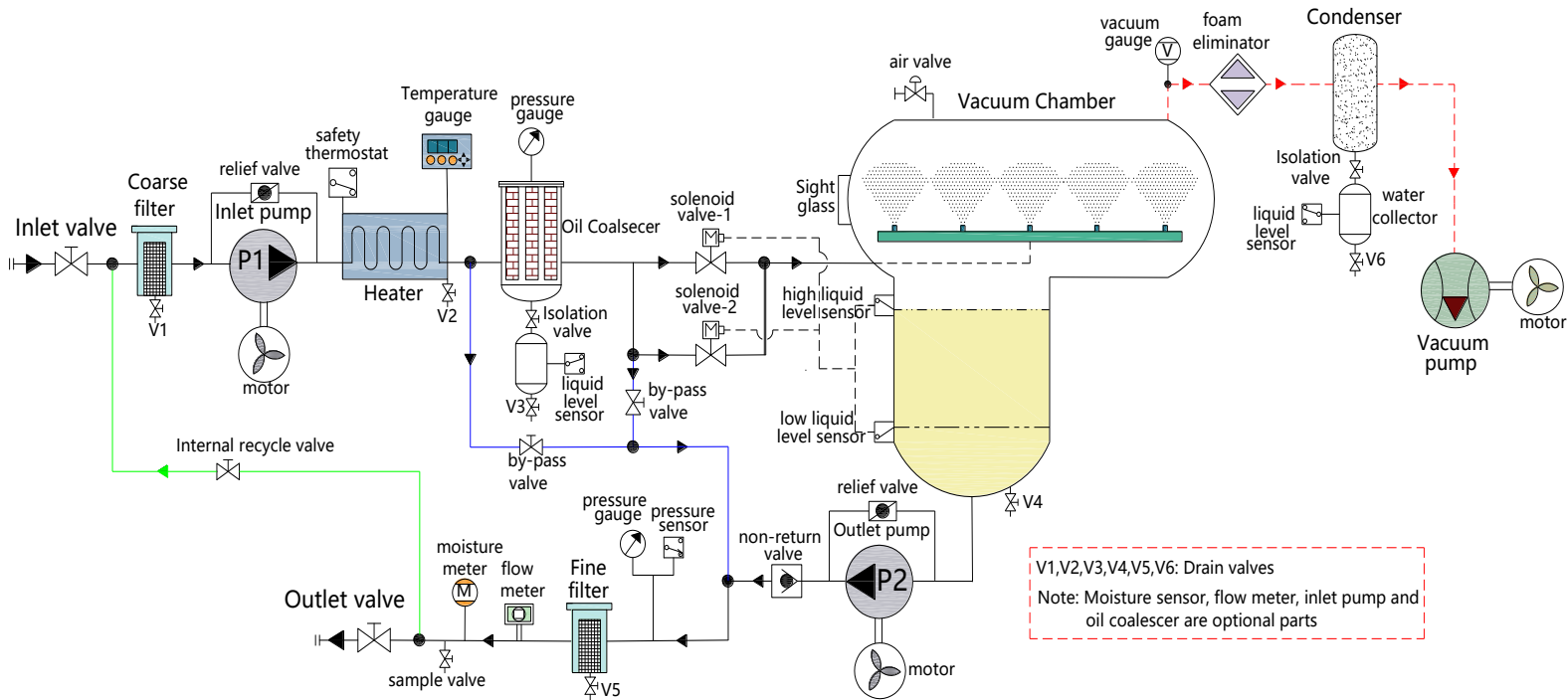

## Specifications of Components

### Electric controlling panel

All electrical control gear, mains Isolating arrangement, starters, contactors, Indicating lamp, push buttons, fuses, relays, Interlocking protecting device etc. are housed in a compact control panel sheets. A mimic diagram is provided on the control panel.

The main components of the electrical apparatus can ensure the safety of the controlling system. The interlocked protective system and pressure protective device which will avoid overload, over voltage, pumping without oil, heating without oil, oil leak, electricity leak and prevent any damages to equipment due to operating error or power failure.

### Heater

The unit equips a digital temperature controller as a safety thermostat, which has a reliable thermocouple sensor mounted in a pocket inside the vessel. The temperature can be set by manually and with capable of heating oil from 20°C to 80°C. The designed temperature range can protect the safety both device and worker. The deterioration of the oil caused by overheating is avoided.

Heating elements is made in refractory formers and don't directly contact with oil so that localized overheating, hot spot and breaking of oil is avoided. The heating components can warm up temperature around and heat radiation, container can uniformly warm up the oil, adopting low load of heated surface, less than 1.5W/cm<sup>2</sup>.

The heater has safety protection device with sensor, which can avoid heating without oil. It is secure and reliable. Construction of the heat exchanger shall be such that the replacement of heaters is easy and shall not require any special tools. A drain valve for the heater tank is provided.

### Inlet & Outlet Pump (Inlet pump are optional)

**Inlet pump(Optional):** Positive displacement gear type driven by electric motor; flow control valve & pressure safety valve against over-pressure is provided. Interlocking arrangement is provided between the inlet pump and the heater I, so that the heater cannot be energized unless inlet pump is ON. Interlocking arrangement between the inlet pump and high level switch avoid excessive rise of oil in the vacuum chambers.

**Discharge Pump:** suitable for sucking oil from the vacuum chambers held under vacuum. This is fully tested for pressure and vacuum leak rate. The pump is of robust construction and capable of developing pressures of up to 200 PSI. Interlocking arrangement is provided between low level switch and discharge pump to prevent dry running of discharge pump.

### Vacuum Pump

A rotary vane vacuum pump is a sort of vacuum production equipment, it is suitable for pumping air and make the oil purifier working under high vacuum status. It uses air cooler to avoid the high temperature of vacuum pump

A condenser between vacuum pump and vacuum chamber reduces the temperature of vapor and avoids the vacuum pump damaged by high temperature of vapor.

### Vacuum Dehydration & Degasification Chambers

Vacuum dehydration & degasification chamber is composed of horizontal & vertical vacuum dehydration & degassing chambers. Under the high vacuum status, vacuum evaporation vessel enlarges evaporation area efficiently, leading to the formation of film-alike oil and stereo-evaporation. The prayer jets are provided at each of the vacuum vessel and become an evaporator. This unique design improves the contact surface area of oil exposed in vacuum system and extends sufficient time to ensure maximum operating efficiency in the removal of gas and moisture. The gas can be quickly sucked out by vacuum pump.

Sight glass viewer or Illuminating lamp for observation of oil flow is provided.

### Filtering System

The filtration system is composed of different precision cartridge filter elements, it features unique design, large filtering area, strong particles-absorbing ability, the impurities with different particulate sizes are filtered step by step. The filtration system has stable and perfect filtering precision. The filter elements are easy to clean or replaced.

**Coarse filter:** the filter element is made of stainless steel, its function uses to prevent any damage to the inlet pump. It has strainers capable of retaining all particles above 100 micron. It is possible to clean the strainer without dismantling the filter.

**Oil Coalescer(optional):** This coalescer oil water separating filter elements are made of specialized glass fiber, which can remove free and emulsified water from oil. When free water is more than 1000ppm, we suggest to choose the coalescer.

**Fine filter:** This filter element allows to accept a standard filter separating particles as small as 1 micron.

Pressure gauge and pressure protector is provided on the filter vessel in order to ascertain condition of cartridge elements and avoid the overpressure.

### Liquid-level Controller

The automatic electric float ball switch is provided in the vacuum chambers to protect the vacuum chamber from overfilling and too low oil. It connects with inlet/outlet pump, electromagnetic valve to control balance of inlet and

outlet oil quantity, it prevents the insulating oil to penetrate into the vacuum pump, prevent the oil level in the chamber to get too high and too low, avoiding to outlet pump running without oil.

A oil foam sensor connected with air valve is provided in vacuum chamber to prevent oil getting into the vacuum pumps if the spray chamber overflows and avoid to damage vacuum pump.

### Condenser

An condenser condenses the vapors to water where it is collected in a stainless steel condensate tank. The condensate tank includes a high level switch that shuts the system down and lights a light on the control panel; automatic water drain is also available.

### Gauges

Compound pressure gauge, vacuum gauge, digital temperature gauge are provided.

Optional: Flow meter, moisture sensor to measure water content of oil.

### Pipe Work:

All pipe work, the vacuum chamber and the filter housings are made from high quality carbon steel. The piping joints are flanged type with O'ring sealing.

### Valves

Different ball valves: inlet/out valves, drain valves of all tanks, electromagnetic /solenoid valves, sample valve are provided.

### Oil Hoses

Two Nos. transparent steel spring type hoses each 10 meters long with flanged end connection on both sides are provided. Oil Hoses capable of handling the transformer oil at 100°C (max.) and vacuum.